

<b>SOLICITATION/CONTRACT/ORDER FOR COMMERCIAL ITEMS</b> <i>OFFEROR TO COMPLETE BLOCKS 12, 17, 23, 24, &amp; 30</i>				1. REQUISITION NUMBER		PAGE OF 1 84	
2. CONTRACT NO. 140L3618A0005		3. AWARD/ EFFECTIVE DATE	4. ORDER NUMBER		5. SOLICITATION NUMBER 140L3618Q0002		6. SOLICITATION ISSUE DATE 01/30/2018
7. <b>FOR SOLICITATION INFORMATION CALL:</b>		a. NAME Velvett Cummins		b. TELEPHONE NUMBER (406) 8965148		8. OFFER DUE DATE/LOCAL TIME MS	
9. ISSUED BY BLM MT-STATE OFC (MT935) 5001 SOUTHGATE DR. BILLINGS MT 59101			CODE LMA	10. THIS ACQUISITION IS <input type="checkbox"/> UNRESTRICTED OR <input checked="" type="checkbox"/> SET ASIDE: 100.00 % FOR: <input checked="" type="checkbox"/> SMALL BUSINESS <input type="checkbox"/> HUBZONE SMALL BUSINESS <input type="checkbox"/> SERVICE-DISABLED VETERAN-OWNED SMALL BUSINESS WOMEN-OWNED SMALL BUSINESS (WOSB) ELIGIBLE UNDER THE WOMEN-OWNED SMALL BUSINESS PROGRAM EDWOSB 8(A) NAICS: 115310 SIZE STANDARD: \$7.5			
11. DELIVERY FOR FOB DESTINATION UNLESS BLOCK IS MARKED <input type="checkbox"/> SEE SCHEDULE		12. DISCOUNT TERMS ACCP		13a. THIS CONTRACT IS A RATED ORDER UNDER DPAS (15 CFR 700) <input type="checkbox"/>		13b. RATING	
15. DELIVER TO As Indicated On Each Call		CODE	16. ADMINISTERED BY BLM MT STATE OFC (MT935) 5001 SOUTHGATE DR. BILLINGS MT 59101				
17a. CONTRACTOR/ OFFEROR PRICE CONTRACTING, INC. Attn: Ron Price 1237 HANLAN LN STEVENSVILLE MT 59870-6149 TELEPHONE NO. 406-370-4347		CODE 0071305028	FACILITY CODE	18a. PAYMENT WILL BE MADE BY As Indicated On Each Call			
<input type="checkbox"/> 17b. CHECK IF REMITTANCE IS DIFFERENT AND PUT SUCH ADDRESS IN OFFER				18b. SUBMIT INVOICES TO ADDRESS SHOWN IN BLOCK 18a UNLESS BLOCK BELOW IS CHECKED <input type="checkbox"/> SEE ADDENDUM			
19. ITEM NO.	20. SCHEDULE OF SUPPLIES/SERVICES			21. QUANTITY	22. UNIT	23. UNIT PRICE	24. AMOUNT
	2018-2021 Fuel Tender Northern Rockies Region 1 Must bring a copy of this award to all assignments, no exceptions.  <i>(Use Reverse and/or Attach Additional Sheets as Necessary)</i>						
25. ACCOUNTING AND APPROPRIATION DATA As Indicated On Each Call						26. TOTAL AWARD AMOUNT (For Govt. Use Only) \$0.00	
<input type="checkbox"/> 27a. SOLICITATION INCORPORATES BY REFERENCE FAR 52.212-1, 52.212-4. FAR 52.212-3 AND 52.212-5 ARE ATTACHED. ADDENDA <input type="checkbox"/> ARE <input type="checkbox"/> ARE NOT ATTACHED.				<input checked="" type="checkbox"/> 27b. CONTRACT/PURCHASE ORDER INCORPORATES BY REFERENCE FAR 52.212-4. FAR 52.212-5 IS ATTACHED. ADDENDA <input type="checkbox"/> ARE <input checked="" type="checkbox"/> ARE NOT ATTACHED.			
<input checked="" type="checkbox"/> 28. CONTRACTOR IS REQUIRED TO SIGN THIS DOCUMENT AND RETURN <u>1</u> COPIES TO ISSUING OFFICE. CONTRACTOR AGREES TO FURNISH AND DELIVER ALL ITEMS SET FORTH OR OTHERWISE IDENTIFIED ABOVE AND ON ANY ADDITIONAL SHEETS SUBJECT TO THE TERMS AND CONDITIONS SPECIFIED.				<input type="checkbox"/> 29. AWARD OF CONTRACT: _____ OFFER DATED _____. YOUR OFFER ON SOLICITATION (BLOCK 5), INCLUDING ANY ADDITIONS OR CHANGES WHICH ARE SET FORTH HEREIN, IS ACCEPTED AS TO ITEMS:			
30a. SIGNATURE OF OFFEROR/CONTRACTOR 				31a. UNITED STATES OF AMERICA (SIGNATURE OF CONTRACTING OFFICER)			
30b. NAME AND TITLE OF SIGNER (Type or print) Ron Price - V.P.		30c. DATE SIGNED 16 May 18		31b. NAME OF CONTRACTING OFFICER (Type or print) Velvett Cummins		31c. DATE SIGNED	

19. ITEM NO.	20. SCHEDULE OF SUPPLIES/SERVICES	21. QUANTITY	22. UNIT	23. UNIT PRICE	24. AMOUNT
	<p>Name of Contact: Ron Price                      Phone: 406-370-4347, 406-370-9924 Day                      406-370-4649 Evening</p> <p>Daily Rate Truck 1: \$1900                      VIN-IHTSCAAPXTH276583                      Mileage Rate Per Mile: \$3.00</p> <p>Legacy Doc #: BLM CO Invoice Review Required: Y                      Period of Performance: 06/01/2018 to 06/01/2021</p> <p>The total amount of award: \$0.00. The obligation                      for this award is shown in box 26.</p>				

32a. QUANTITY IN COLUMN 21 HAS BEEN

RECEIVED     INSPECTED     ACCEPTED, AND CONFORMS TO THE CONTRACT, EXCEPT AS NOTED: \_\_\_\_\_

32b. SIGNATURE OF AUTHORIZED GOVERNMENT REPRESENTATIVE	32c. DATE	32d. PRINTED NAME AND TITLE OF AUTHORIZED GOVERNMENT REPRESENTATIVE
--	-----------	---

32e. MAILING ADDRESS OF AUTHORIZED GOVERNMENT REPRESENTATIVE	32f. TELEPHONE NUMBER OF AUTHORIZED GOVERNMENT REPRESENTATIVE
	32g. E-MAIL OF AUTHORIZED GOVERNMENT REPRESENTATIVE

33. SHIP NUMBER  <input type="checkbox"/> PARTIAL <input type="checkbox"/> FINAL	34. VOUCHER NUMBER	35. AMOUNT VERIFIED CORRECT FOR	36. PAYMENT  <input type="checkbox"/> COMPLETE <input type="checkbox"/> PARTIAL <input type="checkbox"/> FINAL	37. CHECK NUMBER
--	--------------------	---------------------------------	--	------------------

38. S/R ACCOUNT NUMBER	39. S/R VOUCHER NUMBER	40. PAID BY
------------------------	------------------------	-------------

41a. I CERTIFY THIS ACCOUNT IS CORRECT AND PROPER FOR PAYMENT	42a. RECEIVED BY ( <i>Print</i> )
41b. SIGNATURE AND TITLE OF CERTIFYING OFFICER	41c. DATE
	42b. RECEIVED AT ( <i>Location</i> )
	42c. DATE REC'D (YY/MM/DD)
	42d. TOTAL CONTAINERS

**Table of Contents**

Notice to Quoters ..... 1  
Section C: Statement of Work.....2  
Section I: Clauses ..... 26  
Section K: Provisions ..... 33  
Section J: List of Documents and Other Attachments .....50  
Section L: Instructions, Conditions, and Notices..... 51  
Section M: Evaluation Factor for Award .....52

**Notice to Quoters:**

The intent of this Solicitation is, Multiple Award Agreements, to obtain Fuel Tender Service for Northern Rockies Geographic Area for Fire Suppression and all hazard incidents. Only one agreement will be awarded to each individual contractor. The agreement resulting from the Request for Quote (RFQ) may be used by multiple State and Federal Agencies. The Government reserves the right to award all, some, or none of the schedule.

Individual orders will be placed against the Agreement. Since the equipment needs of the Government and availability of Contractor's equipment during an emergency cannot be determined in advance, it is mutually agreed that, upon request of the Government, the Contractor shall furnish the equipment listed herein to the extent the Contractor is willing and able at the time of order.

The Government is not obligated to place nor is the Contractor obligated to accept an order under this Agreement, but if an order is placed and accepted, all the terms and conditions set forth herein shall be met. There are no minimum or maximum guarantees as to the number of orders that may be placed under this Agreement. This agreement does not preclude the Government from using any Agency or Agency Cooperator owned resources before using resources under this agreement.

The proposed rate(s) are fully operated and shall include, but are not limited to, labor, equipment, operating supplies, materials, State and Federal taxes (including worker's compensation costs), insurance coverage, lodging, transportation costs, overhead, profit, and any costs/fees necessary to ensure equipment/operators meet(s) the specified standards. **Daily Rates should reflect the anticipation of operating equipment up to 16 hours per day.**

Offerors will propose a mileage rate for transportation costs to and from the incident (mobilization and demobilization). **Do not include mileage in the daily rate.**

Adequate operators shall be provided to meet the work/rest safety guidelines (**Refer to C.6.7 Statement of Work**). The Finance Unit will work in tandem with the Planning Section to ensure contract resources are meeting the 2:1 work/rest safety guidelines.

Resources furnished under this agreement may be operated and subjected to extreme environmental and/or strenuous operating conditions, which, could include but is not limited to unimproved roads, steep, rocky, hilly terrain, dust, heat, and smoky conditions. As a result, by

entering into this agreement, the contractor agrees that what is considered wear and tear under this agreement is in excess of what the resource is subjected to under normal operations and is reflected in the rates paid for the resources.

The Incident Commander or responsible Government Representative is authorized to administer the technical aspects of this agreement.

**NOTE: Agreements starting in 2019 will require brakes on all axles.**

### **Section C: Statement of Work:**

1. **Agreement Period:** The estimated date of award is May 2018. The agreement period is for Three Years (2018-2021) and will result in a daily rate agreement including mileage.
2. **This agreement supersedes all Northern Rockies Geographic Area Fuel Tender Service EERAs in effect after the award date. This includes all equipment and pricing schedules. Contractor shall not renegotiate set rates when accepting a resource assignment under this award.**
3. Contractor shall not sign up the same equipment listed under this agreement with any other agreement to include National Park Service (NPS), United States Forestry Service (USFS), Bureau of Indian Affairs (BIA), Department of Natural Resources, and Conservation (DNRC), Fish & Wildlife Service (FWS), Idaho Department of Lands (IDL). **(I.e. shall not have the same equipment listed under this agreement signed up under more than one agreement.)**
4. It is estimated that the anticipated use period for resources within the Northern Rockies Geographic area may fall between June 1 and October 1 of each year. Potential use outside this period or anticipated use period could occur at any time.
5. Awarded BPA's will be emailed to the Contractor. Contractor shall have an email account setup in order to receive correspondence in a timely manner. Contractors must accept the offer of award within 10 days. Failure to accept offer of award within specified time implies rejection of the offer. The Contractor will provide availability status to the designated dispatch office within 10 days after award of agreement. **It is the Contractors responsibility to ensure any EERA/BPA's given in addition to the incident agreement number, will also reflect this agreement number.** Failure to do so could result in a delay for payment processing.
6. The Government or the Contractor can terminate the Agreement at any time by providing a 30-day notice in writing. The Government is obligated only to the extent of the authorized orders actually placed under any Agreement.
7. A resource list for Fuel Tender will be established following acceptance of awards. In the event awards are equal, those Contractors names will be randomly drawn at the time of dispatch based upon proximity to the incident, past performance, and price to

determine priority for that incident.

**C.1.1 Location/Description:**

1. The primary location for assignments shall be in the Northern Rockies Geographic Area set forth in the Agreement. Northern Rockies Geographic Dispatch Zones for northern Idaho, Montana, and North Dakota with contact information is available at:
  - a. <http://www.fs.fed.us/r1/fire/nrcg/agree-contract/signup.html>

CDC – Coeur d’ Alene, ID	BRC – Hamilton, MT	BDC – Billings, MT
GVC – Grangeville, ID	DDC – Dillon, MT	LEC – Lewistown, MT
KDC – Libby, MT	HDC – Helena, MT	MCC – Miles City, MT
KIC – Kalispell, MT	GDC – Great Falls, MT	NDC – Bismark, ND
MDC – Missoula, MT	BZC – Bozeman, MT	

**C.1.2 Quotes:**

1. Quotes for Fuel Tender services shall only be accepted for the primary geographic area where the Fuel Tender and operator will be located during the fire season. Only one agreement will be executed for all equipment signed up for an individual contractor to include all of the contractor’s physical locations.
2. Prior to execution of any agreement, the vehicle shall be inspected by the Government to determine that it meets all the terms, conditions and specifications set forth herein. In addition to meeting all applicable Federal Department of Transportation, State and Fuel Tender requirements, adequate public liability, property damage and Workman's Compensation insurances and OSHA compliance, the truck shall be safe (brakes, tires, headlights, turn indicators, etc.), in good mechanical condition, and meet all applicable Federal, State and local fire regulations relating to motor vehicles and equipment. Equipment that fails the inspection or fails to comply with State laws, such as gross vehicle weight laws for the capacity offered shall be rejected. Government may allow one re-inspection after the failed inspection when failure reasons are rectified. **Contractors may not attempt to find another federal or state agency to inspect failed equipment without discussing the circumstances with the Contracting Officer.**
3. In addition to the pre-award certification for Fuel Tender inspection and pre-use inspections, each truck may be inspected at any time it is under hire. Trucks that fail to meet all the requirements herein shall be considered as withdrawn (**Refer to C.17 Incident Pre-Use Inspection**). Equipment failing any inspection may be given the 24hrs to remedy any issue, at the discretion of the IC. (**Refer to C.18 Non-Compliance After Acceptance at the Incident**).
4. An agreement will be entered into with each contractor meeting all the requirements set forth herein. No agreement will be signed when the price is not within a reasonable

range when compared to other quotations for the same equipment. If the price range is too low, the Contractor may be contacted

## **C.2 EQUIPMENT REQUIREMENTS:**

1. Equipment shall meet all standards established by specification or incorporated by reference and shall be maintained in good repair by the Contractor.
2. The preferred method of hire is a daily rate with the contractor providing the operating supplies, one operator per shift, and the ability to accept major creditcards.
3. Contractors shall accept major credit cards for payment of fuel at the work site. (i.e. VISA, MasterCard, Discover, American Express)
  - a. If the Contractor is unable to run or accept credit cards, a 3% deduction from the Daily Rate shall apply.
  - b. WEX Cards are not considered major credit cards. A 3% addition will be made to the daily rate if the vendor runs the WEX card at the incident
  - c. If accepting WEX Cards Contractors need to ensure the following information is collected, otherwise there may be a delay in payment processing to the Contractor.
    - i. WEX Card PIN
    - ii. Vehicle Mileage at the time of fuel purchase
4. If camp location precludes the use of credit cards, the contractor shall use a credit card imprinter to run the credit card upon returning to their designated office.
5. The Emergency Equipment Fuel and Oil Issue tickets, OF-304, will be used if applicable.
6. Fuel Tender shall be fully registered as a commercial vehicle and be current with all DOT, EPA and state inspection requirements.
7. Fuel Tenders shall be provided with a qualified operator at all times.
8. Fuel Tender dispensing system must have a separate dispensing system for each product offered.
9. Fuel Tender meter shall meet certification requirements to measure accurate deliveries in the state where the vehicle is licensed. (State Weights & Measures or equivalent agency)
10. Spill containment kits are required and must meet state hazardous materials containment requirements.

11. No separate payments will be made for nursing tender or spill containment kits.

**C.2.1 Contractor Provided Equipment:**

1. Equipment Typing:

- a. Fuel Tender
  - i. Type I – 2500 + gallons
  - ii. Type II – 1500-2499 gallons
  - iii. Type III – 1000-1499 gallons

**C.2.2 Fuel Tender:**

1. Fuel Tender tank- shall have the following proof of testing:

- a. Have proof of a current yearly visual and leakage (VK) test
- b. Have proof of an Internal and Pressure (I&P) inspection within the last 5 years
- c. All fuel tenders must comply with local certification processes for Northern Rockies Geographic Area

2. Valves:

- a. All tank control valves shall be protected by an emergency shutoff valve.
  - i. This applies regardless of the location of the valve on the tank (Top/Bottom)
- b. Handles should be painted red or a decal should direct the user to the emergency valve.
- c. All valves should shut completely with no leaking fuel
- d. Tank control valves equipped with fusible nuts

3. Wiring:

- a. All electrical wiring within tank compartments shall be covered with no exposed wire
- b. All lights and switches shall be in explosion proof housings

- c. Openings into fixtures shall be protected with rubber grommets to seal out fuel fumes.
4. Hoses and nozzles:
- a. All hoses shall be in good condition with no deep cracks or leaking surfaces.
  - d. Nozzles shall be of proper size for dispensing fuel
  - e. Large nozzle for Diesel
  - f. Small nozzle for Unleaded
  - g. Hoses shall be in good condition with no deep cracks or leaking surfaces
  - h. Fuel Tender must have a bonded hose reel and or a ground rod and cable for grounding the tender while fueling.

**C.2.3 Safety Items:**

1. 2A-10BC Fire Extinguisher
2. Fuel spill response kit: (must meet hazardous material containment requirements) (This section is subject to change as the HAZMAT regulations change):
  - a. Minimum of a five (5) gallon bucket to serve as a spill skit or commercial spill kit bag
  - b. 10 each 15x19 inch White oil – Only heavy weight sonic bonded pads
  - c. 2 each 3” W x 4” L White oil – only sorbent socks
  - d. One pair of nitrile gloves
  - e. One pair of safety goggles
  - f. One each 30” x 6” x 60” yellow Disposal Bag & Tie
3. Hazardous materials compliance pocketbook (Most Current Edition)
4. Emergency Response guidebook (Most Current Edition)

**C.2.4 Operational Requirements:**

- (a) The Contractor shall provide a properly trained and licensed operator to manage the daily

operations of the fuel tender. The Contractor shall be responsible to provide fuel for the incident in a safe and efficient manner.

(b) Contractors shall be able to accept all major credit cards for payment of fuel and providing complete the Emergency Equipment Fuel and Oil Issue tickets, OF-304, and reconcile the with the finance section on a daily basis.

(1) Per gallon price will be established at the time of hire based on the vendors cost plus a reasonable markup to include consideration for credit card surcharges if applicable. Vendor fuel costs supporting the price per gallon may be requested by the Government. Per gallon prices shall be displayed in a visible fashion.

(2) No separate payments will be made for nursing tender or spill containment kits or structures.

(3) Off-road diesel fuel shall not be dispensed by the fuel tender.

### **C.2.5 Fuel:**

1. Fuel will be paid at the current bulk fuel price.
2. Per gallon price will be established at the time of hire and shall be displayed in a visible fashion.
3. Due to the rapidly changing nature of fuel prices, no guarantees can be made for prices of fuel.
4. Off-road diesel fuel shall not be provided by the fuel tender.
5. Types and quantities of Fuel required, (Diesel & Gasoline), will be established at the time of hire.

### **C.3. FUEL TENDER VEHICLE REQUIREMENTS:**

1. The Contractor shall provide dependable equipment that meets all applicable state and federal laws relating to motor vehicles and equipment. The Government reserves the right to conduct inspections at any time.
2. All transportation vehicles shall be in sound mechanical condition with sufficient horsepower and mainframe configurations to ensure successful performance on roads and highways, or in terrain described in these specifications.
3. **All vehicles under this Agreement shall be able to be legally driven on highways under their own power and be able to travel at a minimum of 50 miles per hour.**

4. Vehicles used under this Agreement shall be licensed and legally operable on all roads.
5. An audible reverse warning device (backup alarm) of 89 decibel or greater measured at 5 feet behind and in the center of the equipment. Switches to activate the alarm will not be allowed.
6. Fire Extinguisher, multi-purpose 2A:10B:C that is securely mounted to the vehicle and accessible by the operator
7. The fire extinguisher shall have a current annual inspection tag and the annual maintenance tag in regards to a 5-year annual inspection and every 12 years regarding a hydrostatic test on all dry powder, metal fire extinguishers.
8. Seat belts shall be available for the driver and any passengers in the Fuel Tender Truck.

**C.3.1 Chock Blocks (2 Required):**

1. Vehicle will be equipped with a pair of wheel chocks constructed of a height of 8 inches or more and a width of 7 inches or more.
2. Wheel Chocks shall be constructed of non-sparking material (aluminum)
3. Wheel Chocks must have a solid bottom of ribbing to prevent sinking in soft soil.
4. Wheel Chocks must have a face beveled at a 30-50 degree bevel.
5. Wheel Chocks base must be 1.4 times the height.
6. Wheel Chocks will be accepted if the manufacture specifies that the Chock meet SAE J-348, NFPA 1901 or 1906 for the size vehicle.

**C.3.2 GVWR/GAWR:**

1. No Fuel Tender shall exceed the manufacturer's GVWR or Gross Axle Weight Rating (GAWR) per axle when the vehicle is fully loaded and equipped.
2. The vehicle GVWR plate should be on the driver's side doorpost, driver's door, or in the glove compartment.
3. If missing or illegible, the Contractor shall provide a GVWR certificate from manufacturer stating front, rear, and total GVWR at the pre-season and incident inspections.
4. Only a written verifiable GVWR from the manufacturer or final stage manufacturer will be accepted.

### **C.3.3 Tires:**

1. Tires shall have loading rating in accordance with the vehicle Gross Vehicle Weight Ratings (GVWR).
2. All tires on the vehicles, including the spare tire, if required, shall have sound sidewalls, body, and tire tread depth of a minimum of 2/32 inch for drive axle and 4/32 inch for steering axle.

### **C.3.4 Prohibited Marking:**

1. Federal regulations prohibit the use of official agency shields or markings on private vehicles or property.

#### **C.3.4.1 Required Marking:**

1. Contractor will label all vehicles and trailers with an official company logo to be visibly located on the vehicles driver and passenger side doors.

### **C.3.5 Staffing and Personnel Requirements:**

1. Personnel Requirements: a) All Contractor personnel shall comply with Exhibit F, Safety Standards. Contractors shall comply with the Fair Labor Standards Act when employing persons under 18 years of age (Ref. 29 CFR 570).  
b) Minimum Age for Firefighting Resources. Persons under 18 years of age shall not perform hazardous or arduous duties during wildland fire management operations, including execution of prescribed burns.
2. Training/Experience: a) The Contractor shall provide all operating supplies and one operator per shift. Each person employed by the Contractor under this Agreement shall meet the following minimum requirements:
  - 1) Commercial Drivers License (CDL) with the appropriate endorsements and medical card valid for the state in which the operator resides.
  - 2) All operators shall be able to operate the equipment safely up to the manufacturers limitations.
  - 3) If tank is greater than 1,000 gallons and the truck has a GVWR of 26,000 pounds or more, a tank endorsement is required.
  - 4) Training certification for Annual Fireline Safety Refresher (RT-130) or equivalent training for each operator. All operators shall be able to operate the equipment safely up to the manufacturer's limitations. A list of Northern Rockies Training Providers can be found at: <http://www.fs.fed.us/r1/fire/nrcg/>b) The government reserves the right to verify training at any time for all operators.

### **C.3.6 English Speaking Requirement:**

1. Communications between Contractor crew personnel and Government incident personnel is mandatory for safe and effective performance. Contractor's representative shall be able to proficiently communicate in English, in the language of the crew, and read and communicate the Incident Action Plan, Safety Alerts, etc.
2. All radio communication on Government-assigned frequencies shall be in English.

#### **C.4 EQUIPMENT RELIABILITY:**

1. The Contractor shall provide dependable equipment that meets all applicable state and federal laws relating to motor vehicles and equipment. The Government reserves the right to conduct inspections at any time.

#### **C.5 AVAILABILITY:**

1. The Contractor is responsible for maintaining their current status by informing their host dispatch center of their availability, or if available, self-status in the Resource Ordering Status System (ROSS). When contract resources are unavailable, the resources will not be eligible for dispatch under the Agreement.

#### **C.6 ORDERING PROTOCOL FOR RESOURCES:**

1. This Agreement does not preclude the Government from using any Agency or Agency Cooperator owned resources before resources are mobilized under this Agreement.
2. The Contractor shall restrict calls to the host dispatch center only. Dispatchers will not provide information, such as "when or if a Contractor will be called for an assignment" or "status of other contractors".

##### **C.6.1 Dispatch Priority:**

1. Each host dispatch center will give dispatch priority to the resource offering the greatest advantage (**Refer to C.6.2**) BEFORE all other private resources not under Agreement with the following exceptions:
  - a. For initial attack, dispatchers will follow the "closest forces" concept and utilize locally available resources according to agency and incident needs. The resource ranking will not be used during initial attack and Contractor resources may or may not be used.
  - b. Tribal preference policy established within reservation jurisdiction.
  - c. Government normally will dispatch resources in accordance with this protocol; however, the number of fire orders in process and actual fire conditions at the time of dispatch may require a deviation from normal procedures in order to respond effectively to such conditions. Any such deviation will be within the discretion of Government, and will not be deemed a violation of any term or condition of this

Agreement.

- d. Upon receipt of a resource order by a host dispatch center, Government Dispatchers will not hold the Contractor resources in reserve as a contingency force in a non-pay status when that resource is available.

**C.6.2 Awarded Equipment for Resource List:**

1. All resources on an awarded Agreement will be listed on a resource list by Host Dispatch Zone or Geographic Area ONLY.

**C.6.3 Ordering Procedures for Resources:**

1. The geographic resource list will identify Contractor resources, location, and price. The Government ordering official (Dispatch, Local Office, etc.) will consult the geographic resource list when an incident occurs and choose the Contractor closest to the incident taking Contractor and mobilization costs into consideration. The ordering official will inform the Contractor of the location, quantity required, and date and time needed. If that Contractor is unable to meet the requirements, the next closest Contractor will be contacted, etc.
2. If all contractor resources on the resource list are depleted within the Host Dispatch Zone, orders will be placed utilizing established dispatch procedures.

**C.6.4 INFORMATION REQUIRED WHEN PLACING ORDERS:**

**C.6.4.1 Acceptance:**

At the time of acceptance of the assignment, the following information will be given to the Contractor:

1. Resource Order Number
2. Incident Order Number and Name of Incident
3. Date and time to report to incident
4. Descriptive location of the designated site where the Contractor shall meet a Government representative. A map, if available, will be provided to the Contractor at time of hire.
5. Incident contact phone number for further information
6. Fire Code/Funding Code
  - a. Prior to departing for the incident, the Contractor shall provide to dispatch the complete name of each person dispatched with the resource, and the Estimated

Time of Delivery (ETD) and Estimated Time of Arrival (ETA) from point of dispatch.

- b. Dispatch offices may use a FAX or email to provide a hard copy of the resource order to the Contractor.

### **C.6.5 DISPATCHING PROCEDURES:**

#### **C.6.5.1 Dispatch:**

1. When receiving a dispatch call, the Contractor shall confirm their availability and ability to meet specified timeframes. If the Contractor cannot be reached or is not able to meet the time and date needed, the dispatcher may proceed with contacting the next resource on the resource list.
2. At time of dispatch, a resource order number will be assigned. The Contractor shall furnish the assigned resource order number upon arrival and check in at the assignment.
3. Contractor shall check in at the assignment at the time agreed upon when dispatched.

#### **C.6.5.2 Travel Time:**

1. The Government shall estimate the travel time to and from the incident.
2. Travel time via ground transportation shall be calculated by dividing distance (from point of hire to incident, or incident-to-incident or incident to point of hire) by average travel speed of 45 mph, plus applicable rest time. (**Payment for travel will be made per C.21.8.**)

### **C.6.6 Emergency Incident Driving:**

1. The Contractor shall follow the driving regulations and work/rest guidelines listed in the **Interagency Incident Business Management Handbook (IIBMH)**. The IIBMH can be found on the National Wildfire Coordinating Group's website using the following link:
  - a. [http://www.nwcg.gov/pms/pubs/iibmh2/pms902\\_iibmh.pdf](http://www.nwcg.gov/pms/pubs/iibmh2/pms902_iibmh.pdf)
2. The Contractor is responsible for complying with all other current Federal, State, and Local driving regulations.

### **C.6.7 Length Of Assignment & Crew Change Out:**

1. Work/rest guidelines are in place to ensure the health and safety of employees. Contractors shall ensure that their personnel adhere to the work/rest guidelines (minimum 2:1 work to rest ratio (for every 2 hours of work or travel, provide 1 hour of sleep and/or rest)).

2. To mitigate exceeding work/rest guidelines and manage the days of rest, the Government has the option to:
  - a. Request the Contractor to provide replacement personnel. Replacement personnel are subject to the work/rest guidelines and must arrive at the incident fully rested. The Government will not pay transportation cost for replacement personnel.
  - b. Release resources after a 14-day assignment.
  - c. With the Government's agreement, the contractor may choose to have their personnel remain at the incident base camp and not be placed on shift to allow proper rest. The time is not compensable when the Contractor is off shift in compliance with the length of assignment provisions. (**Refer to C.21.8.3 (5)**).

#### **C.6.8 Demobilization:**

1. The Incident Commander will determine the priority of demobilization.

#### **C.6.9 Release:**

2. Once released to the host dispatch center, the Contractor shall not accept new resource orders directly, nor seek out reassignments. Any new orders will originate from the host dispatch center.

#### **C.7 PROPERTY:**

##### **C.7.1 Accountable, Durable, and Consumable Goods:**

1. Accountable and durable property will not be loaned or exchanged at the incident.
2. The Contractor shall arrive at the incident fully outfitted and prepared to perform under the terms of the agreement. If the resource, upon arrival at the incident or during the course of the incident does not have the required equipment or personal protective equipment, it will be considered noncompliant.
3. The Contractor may be given 24 hours or a timeframe designated by a Government representative to bring the resource into compliance. (**Refer to C.17- Incident Pre-Use Inspection and C.18, Noncompliance after Acceptance at Incident**).
4. Contractor shall be charged for Consumable Goods supplied by the Government and used by the resource while Under Hire.
  - a. The cost of all Consumable Goods, with the exception of those specifically listed below, shall be deducted from payment to the Contractor.
  - b. At the Government's discretion, the Government may provide the following

incidental consumable goods at no cost, if available:

- i. One-quart plastic canteens
- ii. Plastic sheeting
- iii. Replacement radio batteries
- iv. Replacement headlamp batteries, as required while under hire.

**C.8 INFORMATION TO BE PROVIDED BY CONTRACTOR AT CHECK-IN:**

1. The Contractor shall carry a minimum of one **full, printed and legible** copies of the complete Agreement at all times. The Contractor shall furnish a copy of the complete Agreement to the Finance Unit.

**C.9 LAUNDRY SERVICE:**

1. If the Government provides a laundry service at the incident base camp, the Contractor may utilize the service at no cost.

**C.10 CAMPSITE:**

1. A campsite may be provided.
2. The Contractor shall provide sleeping equipment such as tents or shelters, sleeping bags, etc. If the Government cannot provide a campsite, an overnight allowance may be authorized. (See **C.21.5 Remain Overnight Allowance (RON)**).

**C.11 COMMISSARY:**

1. When authorized in writing by the Contractor, the Contractor's employees shall be permitted to use the commissary when one is available. (**Refer to C.21.8.3 Payments - Exceptions**).

**C.12 TIMEKEEPING:**

1. (**Refer to C.21.9.2**)

**C.13 CONTRACTOR'S REPRESENTATIVE:**

1. Unless otherwise designated, the operator(s) shall be considered the Contractor's Representative for this Agreement.

**C.14 FIRST AID, MEDICAL COVERAGE, AND EMERGENCY EVACUATIONS:**

#### **C.14.1 Medical Expenses:**

1. The contractor is financially responsible for employee medical expenses and coverage.
2. The Government may provide first aid at the incident at no charge to the contractor. Any other medical expenses incurred will be the responsibility of the contractor.
3. If contractor personnel become ill or are otherwise injured and incident transportation is not available, the Government may evacuate or transport the injured/ill person(s) to a medical facility/hospital utilizing a commercial source (e.g. ambulance or air transport such as Lifeflight).
4. Commercial transport costs will be the responsibility of the Contractor.

#### **C.14.2 Medical Documentation:**

1. Contractor shall provide the operator(s) with an adequate supply of appropriate insurance forms, insurance ID card(s), and other necessary documents. Such documents shall accompany the injured/ill person(s) when the medical need arises.

#### **C.15 VEHICLE CLEANING FOR NOXIOUS WEED CONTROL:**

1. The resource shall arrive at the incident or designated inspection point washed and free of noxious weed seeds. While at the incident, the Government will normally provide cleaning facilities. If the Government requires use of commercial facilities, the Government will reimburse the Contractor for these costs based on written receipts.

#### **C.16 PRE-AWARD INSPECTION:**

1. The Northern Rockies (NR) has established Memos of Understanding (MOUs) with inspection providers for inspection of both equipment and personnel qualifications. Vendors must contact a NR inspection MOU holder for inspection schedules and locations for equipment inspections. The list of inspection providers is available on the Northern Rockies Coordinating Group (NRCG) website at: <http://www.fs.fed.us/r1/fire/nrcg/agree-contract/index.html>. All equipment must be inspected; completed equipment inspection forms must be submitted to Contracting Officer no later than close of business on April 27, 2018.  
The equipment offer must match the equipment specification and the inspection form OF- 296 submitted.

#### **C.17 INCIDENT PRE-USE INSPECTION:**

1. All resources furnished under this agreement shall be in acceptable condition. The

Government reserves the right to reject resources that are not in safe and operable condition. Prior to incident use or anytime the resource is under hire, the Government will perform inspections utilizing form OF-296 "Vehicle/Heavy Equipment Safety Inspection Checklist" to insure compliance with the Agreement requirements.

2. The Contractor shall provide proof of insurance (cab card) and a current vehicle registration.
3. If the resource does not pass inspection at the incident or designated inspection station, it is considered noncompliant. The Contractor may be given 24 hours or period designated by Government representatives to bring the resource into compliance. If the resource does not pass inspection, no payment will be made for travel to the incident or point of inspection or return to the point of hire, or for the time that the resource was not available.
4. Upon rejection, resource will be removed from the resource list until such time that the resource is brought into compliance and re-inspected at the Government's convenience.
5. Repeated failures at the pre-use incident inspection may be grounds for cancellation of the Agreement.
6. Government reserves the right to inspect at any time to include accurate deliveries of fuel.

#### **C.17.1 Inspection Reports:**

1. Copies of the incident inspection reports and related documentation shall be distributed as follows:
  - a. See attachment – Needs to match (**Equipment Inspection Form**)
  - b. The original shall remain with the fire documents on Host Unit.
  - c. A duplicate copy given to the Contractor regardless of compliance/non-compliance

#### **C.18 NON-COMPLIANCE AFTER ACCEPTANCE AT THE INCIDENT:**

1. If the resource is released due to noncompliance, documentation shall be immediately forwarded, by the Incident Management Team to the Contracting Officer; and the resource will be removed from the resource list until such time that the resource is brought into compliance and re-inspected at the government's convenience. (**Refer to C.21.8.3 Exceptions**).
2. Repeated notices of non-compliance may be grounds for cancellation of the Agreement.

#### **C.19 WORKMANSHIP:**

1. All work under this Agreement shall be performed in a safe manner to a professional standard.
2. The goal of performance under this Agreement is the suppression of Wild Land Fire and other emergency incident responses. The Incident Commander may release from an incident assignment any Contractor employee deemed incompetent, careless, or otherwise objectionable including violation of Harassment Free Workplace Policy (**Refer to C.19.2 Harassment Free Workplace and Section J. Harassment -Free Workplace Policy**).
3. It will be left to the discretion of the Incident Commander to demobilize an entire resource or to allow replacement of the noncompliant personnel. Documentation of the rationale for release will be provided to the CO subsequent to the action.
4. Accordingly, the Contracting Officer may require, in writing, the Contractors removal from use under this Agreement, any employee found incompetent, careless, or otherwise objectionable including violation of Harassment Free Workplace Policy. The Contracting Officer may require other proof of mitigation.
5. Misconduct may result in the suspension or cancellation of this Agreement. If an employee or crew is terminated, quits, or otherwise is released from the incident for any reason, the Contractor is responsible for returning the employee(s) to the point of hire with a departure time from the Incident Command Post (ICP) no later than 12 hours or time specified by a government official following such decision.
6. The Contractor may, at their discretion, provide such transportation, or request the Incident Management Team (IMT) to arrange for the transportation with all transportation costs deducted from Contractor's payment.
7. If the Contractor does not act in a timely manner (i.e., Contractor's employee(s) not departing from the ICP for return to point of hire within the specified time period), the IMT has authority to transport said employee or arrange for employee's transportation and to deduct all such transportation costs from Contractor's payment.

#### **C.19.1 Incident Behavior:**

1. It is extremely important that inappropriate behavior be recognized and dealt with promptly.
2. Inappropriate behavior is all forms of harassment including sexual and racial harassment.
3. HARASSMENT IN ANY FORM WILL NOT BE TOLERATED.
4. Nonprescription unlawful drugs and alcohol are not permitted at the incident. Possession or use of these substances will result in the Contractor being released from the incident.

5. During off-incident periods, personnel are responsible for proper conduct and maintenance of fitness for duty. Drug or alcohol abuse resulting in unfitness for duty will normally result in the Contractor being released from the incident.
6. Sexual harassment is defined, as unwelcome sexual advances, request for sexual favors, and other verbal or physical conduct of a sexual nature constitute sexual harassment when:
  - a. Submission to such conduct is made either explicitly or implicitly a term or condition of an individual's employment
  - b. Submission to or rejection of such conduct by an individual is used as the basis for employment decisions affecting such individual, or
  - c. Such conduct has the purpose or effect of unreasonably interfering with an individual's work performance or creating an intimidating, hostile, or offensive working environment.

#### **C.19.2 Harassment Free Workplace:**

1. Contractors and all Incident Employees shall abide by "U.S. Code, Title VII, Civil Rights Act of 1964, Executive Order EO-93-05, Secretary's Memorandum 4430-2 Workplace Violence Policy, and Harassment Free Workplace (29 CFR Part 1614)".
2. Regulations can be found at
  - a. [www.gpoaccess.gov/](http://www.gpoaccess.gov/)

#### **C.19.3 Firearm-Weapon Prohibition:**

1. The possession of firearms or other dangerous weapon (18 USC 930 (f) (2) are prohibited at all times while on Government Property and during performance of services, under this agreement unless directly related/used for the service provided. The term dangerous weapon does not include pocketknives with a blade less than 2 ½ inches in length or multipurpose tools such as a Leatherman.

#### **C.19.4 Contractor Provided Documentation and Test Results:**

1. Contractor, upon request, or Contractor Staff, will relinquish all information to include communications whether written, oral, or electronic, and any pertinent documentation. This is to include inspection reports, invoices and other financial information, performance reports, issues while on incident, non-compliance, and health inspection results to the requesting official and the original Contracting Officer.
2. Contractor shall not in any way interfere with the course of this agreement or the

information collected herein. Any information obtained will be used for servicing of this agreement and official use only.

## **C.20 PERFORMANCE EVALUATIONS:**

1. The Contractor's performance will be documented on the Standard Contractor Performance Report which will be completed at the incident by the government representative supervising the work.
2. This form is the only performance evaluation form that will be accepted by the Contracting Officer. The evaluator's signature shall be legible or printed on the form.
3. If the supervising Government representative is released from the incident prior to the release of the resource, the government representative shall complete a performance evaluation prior to demobilization, for work the resource performed under their supervision.
4. A copy of the evaluation form(s) will be given to the Contractor at the incident, one forwarded to the CO, and one copy retained in the Host unit incident file. In addition, one copy will be provided to the Northern Rockies Coordination Center, 5765 West Broadway, Missoula, MT. 59808.
5. The evaluation forms, in addition to other performance information will be utilized to facilitate the compilation of the Contractor's performance report for each Agreement year and may be used in past performance evaluations for future procurements.
  - a. <http://www.fs.fed.us/r1/fire/nrcg/agree-contract/StandardContractorPerformanceReport.pdf>

## **C.21 PAYMENTS:**

1. Payments will be made in accordance with (C.21.8 Payments).

### **C.21.2 Withdrawal of Resource(S):**

(Refer to C.21.8.3(2))

### **C.21.3 Repairs:**

1. Repairs shall be made and paid for by the Contractor. The Government may, at its option, elect, to make such repairs when necessary to keep the resource operating. The cost of such repairs will be \$90 per hour plus parts, and will be deducted from payment to the contractor.

### **C.21.4 Operating Supplies:**

1. Even though this agreement may specify that all operating supplies are to be furnished by the Contractor, the Government may, at its option, elect to furnish such supplies when necessary to keep the resource operating.
2. The cost of such supplies will be determined by the Government and deducted from payment to the Contractor.

#### **C.21.5 Remain Overnight Allowance (Ron):**

1. This is not applicable to travel to and from the incident Contractors are not paid per diem or lodging expenses to and from incidents.
2. When the Government cannot provide a campsite or meals, and if pre-approved by the **user unit** and properly **receipted and invoiced**, actual lodging expenses incurred by Contractors providing services under an Agreement whether for severity or incident responses are reimbursable.
3. Food and drink would be based on maximum CONUS per diem rates minus any Government-provided meals. The maximum allowable rates, excluding taxes, are referenced in the Continental United States (CONUS) rates in the Federal Travel Regulations (FTR).
4. The standard CONUS single occupancy-lodging rate is referenced in CONUS. Double occupancy of hotel rooms may be required. Any associated lodging taxes are reimbursable as documented on the lodging invoice. If the resource is allowed to return to its dispatch location during off-shift time, RON allowance is not authorized.
5. The maximum RON that shall be allowed is based on the number of crewmembers shown on the shift ticket. Payment shall be included as an addition on the OF-286 Emergency Equipment Use Invoice. Documentation of authorization shall be included.

#### **C.21.6 Food & Drink:**

1. Contractors are required to provide sufficient food & drink to support the crew while in travel status and the first shift of the incident. This is not reimbursed by the Government.
2. After that time, when Government subsistence at incident camps are available, meals for Contractor's operator(s) will be furnished without charge. Government will furnish meals without cost if restaurant subsistence is approved for the camp for incident personnel.
3. The Government, during demobilization and/or reassignment, may provide sack lunches to the Contractor personnel without charging the Contractor.

#### **C.21.7 Order Cancellation:**

Order cancellation/enroute. If the order is cancelled after the resource order has been confirmed, and the resource is enroute, the resource is considered mobilized. Payment will be made by the host agency in accordance with D.21.8.

**C.21.8 Payments:**

1. Each incident host agency is responsible for their incident payments, regardless of the contracting agency. The payment office will be designated in block 9 on the Emergency Equipment - Use Invoice, Form OF-286.
2. The time under hire shall start at the time the resource begins traveling to the incident after being ordered by the Government, and end at the estimated time of arrival back to the point of hire after being released, except as provided in (C.21.8.3. Exceptions)

**C.21.8.1 Rates of Payments:**

1. Rates for equipment hired with Contractor furnished operator(s) shall include all operator(s) expenses. Payment will be at rates specified and, except as provided in (C.21.8.3 Exceptions), shall be in accordance with the following:

**a. Time Under Hire:**

- i. The time under hire shall start at the time the equipment begins traveling to the incident after being ordered by the Government, and end at the estimated time of arrival back to the point of hire after being released.

**b. Work Rates:**

- i. (Daily/Mileage/Shift Basis) shall apply when equipment is under hire as ordered by the Government and on shift, including relocation of equipment under its own power.

**c. On-Shift:**

- i. Includes time worked, time that resource is held or directed to be in a state of readiness, and compensable travel (resource traveling under its own power) that has a specific start and ending time

**d. Special Rates:**

- i. Shall apply when specified

**e. Daily Rate:**

- i. Payment will be made on basis of calendar days (0001 - 2400). For fractional days at the beginning and ending of time under hire, payment will be based on 50 percent of the Daily Rate for periods less than 8 hours.
- ii. Under the daily rate, equipment is staffed with operator(s).
- iii. A 3% deduction from the daily rate will apply if unwilling or not able to accept all major credit cards as a form of payment for fuel at the incident.
- iv. WEX Cards are not considered major credit cards

**f. Daily Rate and Mileage:**

- i. Is considered to and from the incident (mobilization and demobilization) from city and state listed on schedule of items.
- ii. Government directed mileage (i.e. Spike Camp or Helibase)

**g. Daily Rate:**

- i. Payment will be made on basis of calendar days (0001 \_ 2400). For fractional days at the beginning and ending of time under hire, payment will be based on 50% percent of the Daily Rate for periods less than 8 hours.

**C.21.8.2 Method Of Payment:**

1. Lump-sum payment will normally be processed at the end of the emergency assignment. However, partial payment may be authorized as approved by the incident agency.
2. Payment for each calendar day will be made for actual units ordered and performed under Daily rates.

**C.21.8.3 Exceptions:**

1. No further payment will accrue during any period that resource under hire is not in a safe or operable condition or it is not available for the assigned shift or portions of the assigned shift. Payment will be based on the hours the resource was operational during the assigned shift, as documented on the shift ticket versus the designated shift, as shown on the Incident Action Plan.
2. If the Contractor withdraws resources prior to being released by the Government, no further payment shall accrue and the Contractor shall bear all costs of returning resources to the point of hire.

3. After inspection and acceptance for use, resources that cannot be replaced or be repaired at the site of work by the Contractor or by the Government in accordance with **(C.18 Non-compliance After Acceptance at the Incident)**, within 24 hours, may be considered as being withdrawn by the Contractor. This is in accordance with **(Paragraph b)** above, except that the Government shall pay return travel. The Government shall calculate travel in accordance with **C.21.8.1 Rates of Payments** based on a normal release resource. The Contractor shall bear any additional cost returning resource and/or operator(s) to the point of hire.
4. No payment will accrue when the contractor is off shift in compliance with the mandatory "Work/Rest" and "Length of Assignment" provisions. **(Refer to C.6.7 – Length of Assignments & Crew Change Out)**
5. Deductions, unless specifically stated elsewhere in this agreement, the cost of any supplies, materials, or services, including commissary, provided for the Contractor by the Government will be deducted from the payment to the Contractor.

### **C.21.9 INVOICING PROCESS:**

#### **C.21.9.1 :**

1. The resource shall have One **full, printed, and legible** copies of the Agreement and the Resource Order information for the assigned incident.

#### **C.21.9.2 :**

1. After each operational period worked, time will be verified and approved by the Government Agent responsible for ordering and/or directing use the resource. Time will be recorded to the nearest quarter hour worked.
2. The Government will verify the Contractor's time on an Emergency Equipment Shift Ticket (OF-297) (Refer to Section 3 Internal Attachments, Subsection 3.). The Government and the Contractor representatives will sign the OF-297 verifying the hours worked daily. Each operator's name shall be listed on the shift ticket.

#### **C.21.9.3 :**

1. The Finance Unit or designated representative will post the equipment time to an Emergency Equipment Use Invoice, Optional Form 286 (OF-286)

#### **C.21.9.4 :**

1. When the resource is released to return to the Designated Dispatch Point (DDP), the Finance Unit will close out the Invoice including estimated time for return travel.

#### **C.21.9.5 :**

1. The incident will submit a payment package including all signed originals of OF-286, copy of SF-1449, copy of resource order, and transmittal sheet to the designated incident agency's payment office. The Contractor will be given a copy of all payment documents at the incident.

**C.21.9.6 :**

1. The Agency that requested the resource under this Agreement will be the responsible Agency for Contractor payment. Contractor will be paid according to the terms of this Agreement. This will occur at the time the incident is demobilized, Contractor is released, or sooner as determined by the Finance Unit.

**C.22 TIMEKEEPING:**

1. After each operational period worked, time will be verified and approved by the Government Agent responsible for ordering and/or directing use of the resource. Time will be recorded for daily usage.
2. The Government will verify the Contractor's time on an Emergency Equipment Shift Ticket (OF-297). The Government and the Contractor representatives will sign the OF-297 verifying the hours worked daily.
3. It is the responsibility of the Contractor to turn the completed Emergency Equipment Shift Tickets (OF-297), into the Finance Unit for timeposting.
4. When the resource is released to return to the Host Dispatch Center, the Finance Unit will close out the Emergency Equipment Use Invoice (OF-286).
5. The incident will submit a payment package, including all signed originals of the Emergency Equipment Use Invoice (OF-286), Emergency Equipment Shift Tickets (OF-297), inspection form, and copy of the resource order to the designated incident agency's payment office.
6. The Contractor will be given a copy of all payment documents at the incident.

**D.22 RESOURCE REPLACEMENT**

The intent of this clause is to provide permanent substitution of resources, not intermittent or additional resources. The Contractor is obligated to provide the resources offered in the proposal. New resources may not be added to the agreement with the exception of replacement resources as provided below.

**D.22.1** Replacement of Resources with equal or better equipment may be done at the discretion of the signatory CO through a modification without change to the Agreement rates or position on

the priority dispatch list. Replacement resources shall be inspected and accepted, if required by the solicitation, and approved in advance of use.

**D.22.2** Repair of auxiliary/peripheral equipment with equal or better equipment may be done at any time, and does not require a modification to the agreement. Replacement equipment shall be inspected and accepted, if required by the solicitation, and approved in advance of use. If providing replacement equipment as outlined in this section, Contractor shall submit a copy of all replacement equipment to the contracting officer.

#### **C.24 AUTHORIZED PERSONNEL TO PLACE ORDERS:**

1. Dispatchers, Buying Team Members, Finance Section Chiefs, Procurement Unit Leaders, Contracting Officers, and Purchasing Agents are authorized to place orders against this agreement. Orders must be placed in accordance with established ordering procedures as specified in National and Regional mobilization guides.

#### **C.25 CLAIM SETTLEMENT AUTHORITY:**

1. When settling claims, the successor-contracting officer is any contracting officer acting within their delegated warrant authority, under the clauses of this agreement, and limits set by the incident agency.
2. Claims should be filed and settled by the Contractor or Contractor Representative while at the incident.

#### **C.26 CHANGES TO AGREEMENTS:**

1. **Changes to Agreements may only be made by the original signing procurement official or a designated successor-contracting officer.**
2. If the original signing procurement official or designated successor-contracting officer is not available and adjustments are deemed appropriate, an Emergency Equipment Rental Agreement (EERA) shall be executed at the incident and shall be applicable **only** for the duration of that incident.
3. The EERA must include name and location of the incident, original agreement number that equipment is signed under, name and contact information of contracting officer making the change to include justification for the change.
4. A copy of the EERA will be forwarded to the Contracting Officer located on the original agreement the equipment is signed under.

#### **C.27 LOSS, DAMAGE, OR DESTRUCTION:**

1. For equipment furnished under this agreement **without** an operator, the Government will assume liability for any loss, damage or destruction of such equipment, except that no

reimbursement will be made for loss, damage or destruction due to:

- a. Ordinary wear or tear,
  - b. Mechanical failure, or
  - c. The fault or negligence of the Contractor or the Contractor's agents or employees or Government employee owned and operated equipment.
2. For equipment furnished under this agreement **with** an operator, the Government shall not be liable for any loss, damage or destruction of such equipment, except for loss, damage or destruction resulting from the negligence, or wrongful act(s) of Government employee(s) while acting within the scope of their employment.
  3. The operator is responsible for operating the equipment within its operating limits and responsible for safety of the equipment.

**C.29 FAR 52.247.21 - CONTRACTOR LIABILITY FOR PERSONAL INJURY AND/OR PROPERTY DAMAGE (APR 1984):**

1. The Contractor assumes responsibility for all damage or injury to persons or property occasioned through the use, maintenance, and operation of the Contractor's vehicles or other equipment by, or the action of, the Contractor or the Contractor's employees and agents.
2. The Contractor, at the Contractor's expense, shall maintain adequate public liability and property damage insurance during the continuance of this contract, insuring the Contractor against all claims for injury or damage.
3. The Contractor shall maintain Workers' Compensation and other legally required insurance with respect to the Contractor's own employees and agents.
4. The Government shall in no event be liable or responsible for damage or injury to any person or property occasioned through the use, maintenance, or operation of any vehicle or other equipment by, or the action of, the Contractor or the Contractor's employees and agents in performing under this contract. The Government shall be indemnified and saved harmless against claims for damage or injury in such cases.

## **Section I: Clauses**

### **52.252-2 – Clauses Incorporated by Reference (Feb 1998)**

This contract incorporates one or more clauses incorporated by reference, with the same force and effect as if they were given in full text. Upon request, the Contracting Officer will make their full text available. In addition, the full text of a clause may be accessed electronically at this web address:

### **52.217-8 -- Option to Extend Services.**

#### **Option to Extend Services (Nov 1999)**

The Government may require continued performance of any services within the limits and at the rates specified in the contract. These rates may be adjusted only as a result of revisions to prevailing labor rates provided by the Secretary of Labor. The option provision may be exercised more than once, but the total extension of performance hereunder shall not exceed 6 months. The Contracting Officer may exercise the option by written notice to the Contractor within \_\_\_30\_\_\_ (days).

(End of Clause)

### **52.217-9 -- Option to Extend the Term of the Contract.**

#### **Option to Extend the Term of the Contract (Mar 2000)**

(a) The Government may extend the term of this contract by written notice to the Contractor within \_\_\_30\_\_\_ (days); provided that the Government gives the Contractor a preliminary written notice of its intent to extend at least \_\_\_60\_ (days) before the contract expires. The preliminary notice does not commit the Government to an extension.

(b) If the Government exercises this option, the extended contract shall be considered to include this option clause.

(c) The total duration of this contract, including the exercise of any options under this clause, shall not exceed \_3\_(years).

(End of Clause)

<http://farsite.hill.af.mil/vffara.htm>

**52.204-9 – Personal Identity Verification of Contractor Personnel (Jan 2011)**

**52.204-13 – System for Award Management Maintenance (Oct 2016)**

**52.204-18 - Commercial and Government Entity Code Maintenance (Jul 2016)**

**52.212-4 – Contract Terms and Conditions – Commercial Items (Jan 2017)**

**52.222-22 – Previous Contracts and Compliance Reports (Feb 1999)**

**52.232-18 – Availability of Funds (Apr 1984)**

**52.233-4 – Applicable Law for Breach of Contract Claim (Oct 2004)**

**52.242-15 – Stop Work Order (Aug 1989)**

(End of Clause)

**52.212-5 – Contract Terms and Conditions Required to Implement Statutes or Executive Orders – Commercial Items (Jan 2018)**

(a) The Contractor shall comply with the following Federal Acquisition Regulation (FAR) clauses, which are incorporated in this contract by reference, to implement provisions of law or Executive orders applicable to acquisitions of commercial items:

- (1) [52.203-19](#), Prohibition on Requiring Certain Internal Confidentiality Agreements or Statements (Jan 2017) (section 743 of Division E, Title VII, of the Consolidated and Further Continuing Appropriations Act, 2015 (Pub. L. 113-235) and its successor provisions in subsequent appropriations acts (and as extended in continuing resolutions)).
- (2) [52.209-10](#), Prohibition on Contracting with Inverted Domestic Corporations (Nov 2015).
- (3) [52.233-3](#), Protest After Award (Aug 1996) ([31 U.S.C. 3553](#)).
- (4) [52.233-4](#), Applicable Law for Breach of Contract Claim (Oct 2004)(Public Laws 108-77 and 108-78 ([19 U.S.C. 3805 note](#))).

(b) The Contractor shall comply with the FAR clauses in this paragraph (b) that the Contracting Officer has indicated as being incorporated in this contract by reference to implement provisions of law or Executive orders applicable to acquisitions of commercial items:

[Contracting Officer check as appropriate.]

- \_\_\_ (1) [52.203-6](#), Restrictions on Subcontractor Sales to the Government (Sept 2006), with Alternate I (Oct 1995) ([41 U.S.C. 4704](#) and [10 U.S.C. 2402](#)).
- \_\_\_ (2) [52.203-13](#), Contractor Code of Business Ethics and Conduct (Oct 2015) ([41 U.S.C. 3509](#))).
- \_\_\_ (3) [52.203-15](#), Whistleblower Protections under the American Recovery and Reinvestment Act of 2009 (June 2010) (Section 1553 of Pub. L. 111-5). (Applies to contracts funded by the American Recovery and Reinvestment Act of 2009.)
- \_\_\_ (4) [52.204-10](#), Reporting Executive Compensation and First-Tier Subcontract Awards (Oct 2016) (Pub. L. 109-282) ([31 U.S.C. 6101 note](#)).
- \_\_\_ (5) [Reserved].
- \_\_\_ (6) [52.204-14](#), Service Contract Reporting Requirements (Oct 2016) (Pub. L. 111-117, section 743 of Div. C).
- \_\_\_ (7) [52.204-15](#), Service Contract Reporting Requirements for Indefinite-Delivery Contracts (Oct 2016) (Pub. L. 111-117, section 743 of Div. C).
- \_\_\_ (8) [52.209-6](#), Protecting the Government's Interest When Subcontracting with Contractors Debarred, Suspended, or Proposed for Debarment. (Oct 2015) (31 U.S.C. 6101 note).
- \_\_\_ (9) [52.209-9](#), Updates of Publicly Available Information Regarding Responsibility Matters (Jul 2013) (41 U.S.C. 2313).

- \_\_ (10) [Reserved].
- \_\_ (11)(i) [52.219-3](#), Notice of HUBZone Set-Aside or Sole-Source Award (Nov 2011) ([15 U.S.C. 657a](#)).
- \_\_ (ii) Alternate I (Nov 2011) of [52.219-3](#).
- \_\_ (12)(i) [52.219-4](#), Notice of Price Evaluation Preference for HUBZone Small Business Concerns (Oct 2014) (if the offeror elects to waive the preference, it shall so indicate in its offer) ([15 U.S.C. 657a](#)).
- \_\_ (ii) Alternate I (Jan 2011) of [52.219-4](#).
- \_\_ (13) [Reserved]
- X(14)(i) [52.219-6](#), Notice of Total Small Business Set-Aside (Nov 2011) ([15 U.S.C. 644](#)).
- \_\_ (ii) Alternate I (Nov 2011).
- \_\_ (iii) Alternate II (Nov 2011).
- \_\_ (15)(i) [52.219-7](#), Notice of Partial Small Business Set-Aside (June 2003) ([15 U.S.C. 644](#)).
- \_\_ (ii) Alternate I (Oct 1995) of [52.219-7](#).
- \_\_ (iii) Alternate II (Mar 2004) of [52.219-7](#).
- \_\_ (16) [52.219-8](#), Utilization of Small Business Concerns (Nov 2016) ([15 U.S.C. 637\(d\)\(2\)](#) and (3)).
- \_\_ (17)(i) [52.219-9](#), Small Business Subcontracting Plan (Jan 2017) ([15 U.S.C. 637\(d\)\(4\)](#)).
- \_\_ (ii) Alternate I (Nov 2016) of [52.219-9](#).
- \_\_ (iii) Alternate II (Nov 2016) of [52.219-9](#).
- \_\_ (iv) Alternate III (Nov 2016) of [52.219-9](#).
- \_\_ (v) Alternate IV (Nov 2016) of [52.219-9](#).
- \_\_ (18) [52.219-13](#), Notice of Set-Aside of Orders (Nov 2011) ([15 U.S.C. 644\(r\)](#)).
- \_\_ (19) [52.219-14](#), Limitations on Subcontracting (Jan 2017) ([15 U.S.C. 637\(a\)\(14\)](#)).
- \_\_ (20) [52.219-16](#), Liquidated Damages—Subcontracting Plan (Jan 1999) ([15 U.S.C. 637\(d\)\(4\)\(F\)\(i\)](#)).
- \_\_ (21) [52.219-27](#), Notice of Service-Disabled Veteran-Owned Small Business Set-Aside (Nov 2011) ([15 U.S.C. 657 f](#)).
- \_\_ (22) [52.219-28](#), Post Award Small Business Program Rerepresentation (Jul 2013) ([15 U.S.C. 632\(a\)\(2\)](#)).
- \_\_ (23) [52.219-29](#), Notice of Set-Aside for, or Sole Source Award to, Economically Disadvantaged Women-Owned Small Business Concerns (Dec 2015) ([15 U.S.C. 637\(m\)](#)).
- \_\_ (24) [52.219-30](#), Notice of Set-Aside for, or Sole Source Award to, Women-Owned Small Business Concerns Eligible Under the Women-Owned Small Business Program (Dec 2015) ([15 U.S.C. 637\(m\)](#)).
- X (25) [52.222-3](#), Convict Labor (June 2003) (E.O. 11755).
- X(26) [52.222-19](#), Child Labor—Cooperation with Authorities and Remedies (Oct 2016) (E.O. 13126).
- X (27) [52.222-21](#), Prohibition of Segregated Facilities (Apr 2015).
- X (28) [52.222-26](#), Equal Opportunity (Sept 2016) (E.O. 11246).
- \_\_ (29) [52.222-35](#), Equal Opportunity for Veterans (Oct 2015)([38 U.S.C. 4212](#)).
- \_\_ (30) [52.222-36](#), Equal Opportunity for Workers with Disabilities (Jul 2014) ([29 U.S.C. 793](#)).
- \_\_ (31) [52.222-37](#), Employment Reports on Veterans (Feb 2016) (38 U.S.C. 4212).
- \_\_ (32) [52.222-40](#), Notification of Employee Rights Under the National Labor Relations Act (Dec 2010) (E.O. 13496).

X (33)(i) [52.222-50](#), Combating Trafficking in Persons (Mar 2015) ([22 U.S.C. chapter 78](#) and E.O. 13627).

\_\_ (ii) Alternate I (Mar 2015) of [52.222-50](#) ([22 U.S.C. chapter 78](#) and E.O. 13627).

\_\_ (34) [52.222-54](#), Employment Eligibility Verification (Oct 2015). (Executive Order 12989). (Not applicable to the acquisition of commercially available off-the-shelf items or certain other types of commercial items as prescribed in [22.1803](#).)

\_\_ (35) [52.222-59](#), Compliance with Labor Laws (Executive Order 13673) (Oct 2016). (Applies at \$50 million for solicitations and resultant contracts issued from October 25, 2016 through April 24, 2017; applies at \$500,000 for solicitations and resultant contracts issued after April 24, 2017).

**Note to paragraph (b)(35):** By a court order issued on October 24, 2016, 52.222-59 is enjoined indefinitely as of the date of the order. The enjoined paragraph will become effective immediately if the court terminates the injunction. At that time, GSA, DoD and NASA will publish a document in the Federal Register advising the public of the termination of the injunction.

\_\_ (36) [52.222-60](#), Paycheck Transparency (Executive Order 13673) (OCT 2016).

\_\_ (37)(i) [52.223-9](#), Estimate of Percentage of Recovered Material Content for EPA–Designated Items (May 2008) ([42 U.S.C. 6962\(c\)\(3\)\(A\)\(ii\)](#)). (Not applicable to the acquisition of commercially available off-the-shelf items.)

\_\_ (ii) Alternate I (May 2008) of [52.223-9](#) ([42 U.S.C. 6962\(i\)\(2\)\(C\)](#)). (Not applicable to the acquisition of commercially available off-the-shelf items.)

\_\_ (38) [52.223-11](#), Ozone-Depleting Substances and High Global Warming Potential Hydrofluorocarbons (Jun 2016) (E.O. 13693).

\_\_ (39) [52.223-12](#), Maintenance, Service, Repair, or Disposal of Refrigeration Equipment and Air Conditioners (Jun 2016) (E.O. 13693).

\_\_ (40)(i) [52.223-13](#), Acquisition of EPEAT®-Registered Imaging Equipment (Jun 2014) (E.O.s 13423 and 13514).

\_\_ (ii) Alternate I (Oct 2015) of [52.223-13](#).

\_\_ (41)(i) [52.223-14](#), Acquisition of EPEAT®-Registered Televisions (Jun 2014) (E.O.s 13423 and 13514).

\_\_ (ii) Alternate I (Jun 2014) of [52.223-14](#).

\_\_ (42) [52.223-15](#), Energy Efficiency in Energy-Consuming Products (Dec 2007) ([42 U.S.C. 8259b](#)).

\_\_ (43)(i) [52.223-16](#), Acquisition of EPEAT®-Registered Personal Computer Products (Oct 2015) (E.O.s 13423 and 13514).

\_\_ (ii) Alternate I (Jun 2014) of [52.223-16](#).

X (44) [52.223-18](#), Encouraging Contractor Policies to Ban Text Messaging While Driving (Aug 2011) (E.O. 13513).

\_\_ (45) [52.223-20](#), Aerosols (Jun 2016) (E.O. 13693).

\_\_ (46) [52.223-21](#), Foams (Jun 2016) (E.O. 13693).

\_\_ (47)(i) [52.224-3](#), Privacy Training (JAN 2017) (5 U.S.C. 552a).

\_\_ (ii) Alternate I (JAN 2017) of [52.224-3](#).

\_\_ (48) [52.225-1](#), Buy American—Supplies (May 2014) ([41 U.S.C. chapter 83](#)).

\_\_ (49)(i) [52.225-3](#), Buy American—Free Trade Agreements—Israeli Trade Act (May 2014) ([41 U.S.C. chapter 83](#), [19 U.S.C. 3301](#) note, [19 U.S.C. 2112](#) note, [19 U.S.C. 3805](#) note, [19 U.S.C.](#)

[4001](#) note, Pub. L. 103-182, 108-77, 108-78, 108-286, 108-302, 109-53, 109-169, 109-283, 110-138, 112-41, 112-42, and 112-43.

\_\_ (ii) Alternate I (May 2014) of [52.225-3](#).

\_\_ (iii) Alternate II (May 2014) of [52.225-3](#).

\_\_ (iv) Alternate III (May 2014) of [52.225-3](#).

\_\_ (50) [52.225-5](#), Trade Agreements (Oct 2016) ([19 U.S.C. 2501](#), et seq., [19 U.S.C. 3301](#) note).

\_\_ (51) [52.225-13](#), Restrictions on Certain Foreign Purchases (June 2008) (E.O.'s, proclamations, and statutes administered by the Office of Foreign Assets Control of the Department of the Treasury).

\_\_ (52) [52.225-26](#), Contractors Performing Private Security Functions Outside the United States (Oct 2016) (Section 862, as amended, of the National Defense Authorization Act for Fiscal Year 2008; [10 U.S.C. 2302 Note](#)).

\_\_ (53) [52.226-4](#), Notice of Disaster or Emergency Area Set-Aside (Nov 2007) ([42 U.S.C. 5150](#)).

\_\_ (54) [52.226-5](#), Restrictions on Subcontracting Outside Disaster or Emergency Area (Nov 2007) ([42 U.S.C. 5150](#)).

\_\_ (55) [52.232-29](#), Terms for Financing of Purchases of Commercial Items (Feb 2002) ([41 U.S.C. 4505](#), [10 U.S.C. 2307\(f\)](#)).

\_\_ (56) [52.232-30](#), Installment Payments for Commercial Items (Jan 2017) ([41 U.S.C. 4505](#), [10 U.S.C. 2307\(f\)](#)).

X (57) [52.232-33](#), Payment by Electronic Funds Transfer—System for Award Management (Jul 2013) ([31 U.S.C. 3332](#)).

\_\_ (58) [52.232-34](#), Payment by Electronic Funds Transfer—Other than System for Award Management (Jul 2013) ([31 U.S.C. 3332](#)).

\_\_ (59) [52.232-36](#), Payment by Third Party (May 2014) ([31 U.S.C. 3332](#)).

\_\_ (60) [52.239-1](#), Privacy or Security Safeguards (Aug 1996) ([5 U.S.C. 552a](#)).

\_\_ (61) [52.242-5](#), Payments to Small Business Subcontractors (Jan 2017)([15 U.S.C. 637\(d\)\(12\)](#)).

\_\_ (62)(i) [52.247-64](#), Preference for Privately Owned U.S.-Flag Commercial Vessels (Feb 2006) ([46 U.S.C. Appx. 1241\(b\)](#) and [10 U.S.C. 2631](#)).

\_\_ (ii) Alternate I (Apr 2003) of [52.247-64](#).

(c) The Contractor shall comply with the FAR clauses in this paragraph (c), applicable to commercial services, that the Contracting Officer has indicated as being incorporated in this contract by reference to implement provisions of law or Executive orders applicable to acquisitions of commercial items:

[Contracting Officer check as appropriate.]

\_\_ (1) [52.222-17](#), Nondisplacement of Qualified Workers (May 2014)(E.O. 13495).

X (2) [52.222-41](#), Service Contract Labor Standards (May 2014) ([41 U.S.C. chapter 67](#)).

X (3) [52.222-42](#), Statement of Equivalent Rates for Federal Hires (May 2014) ([29 U.S.C. 206](#) and [41 U.S.C. chapter 67](#)).

**31361 Truck driver, Light Truck**  
**31362 Truck driver, Medium Truck**  
**31363 Truckdriver, Heavy Truck**  
**31364 Truckdriver, Tractor Traile**

- \_\_\_ (4) [52.222-43](#), Fair Labor Standards Act and Service Contract Labor Standards-Price Adjustment (Multiple Year and Option Contracts) (May 2014) ([29 U.S.C. 206](#) and [41 U.S.C. chapter 67](#)).
  - \_\_\_ (5) [52.222-44](#), Fair Labor Standards Act and Service Contract Labor Standards—Price Adjustment (May 2014) ([29 U.S.C. 206](#) and [41 U.S.C. chapter 67](#)).
  - \_\_\_ (6) [52.222-51](#), Exemption from Application of the Service Contract Labor Standards to Contracts for Maintenance, Calibration, or Repair of Certain Equipment—Requirements (May 2014) ([41 U.S.C. chapter 67](#)).
  - \_\_\_ (7) [52.222-53](#), Exemption from Application of the Service Contract Labor Standards to Contracts for Certain Services—Requirements (May 2014) ([41 U.S.C. chapter 67](#)).
  - \_\_\_ (8) [52.222-55](#), Minimum Wages Under Executive Order 13658 (Dec 2015).
  - \_\_\_ (9) [52.222-62](#), Paid Sick Leave Under Executive Order 13706 (JAN 2017) (E.O. 13706).
  - \_\_\_ (10) [52.226-6](#), Promoting Excess Food Donation to Nonprofit Organizations (May 2014) ([42 U.S.C. 1792](#)).
  - \_\_\_ (11) [52.237-11](#), Accepting and Dispensing of \$1 Coin (Sept 2008) ([31 U.S.C. 5112\(p\)\(1\)](#)).
- (d) Comptroller General Examination of Record. The Contractor shall comply with the provisions of this paragraph (d) if this contract was awarded using other than sealed bid, is in excess of the simplified acquisition threshold, and does not contain the clause at [52.215-2](#), Audit and Records—Negotiation.
- (1) The Comptroller General of the United States, or an authorized representative of the Comptroller General, shall have access to and right to examine any of the Contractor’s directly pertinent records involving transactions related to this contract.
  - (2) The Contractor shall make available at its offices at all reasonable times the records, materials, and other evidence for examination, audit, or reproduction, until 3 years after final payment under this contract or for any shorter period specified in FAR [subpart 4.7](#), Contractor Records Retention, of the other clauses of this contract. If this contract is completely or partially terminated, the records relating to the work terminated shall be made available for 3 years after any resulting final termination settlement. Records relating to appeals under the disputes clause or to litigation or the settlement of claims arising under or relating to this contract shall be made available until such appeals, litigation, or claims are finally resolved.
  - (3) As used in this clause, records include books, documents, accounting procedures and practices, and other data, regardless of type and regardless of form. This does not require the Contractor to create or maintain any record that the Contractor does not maintain in the ordinary course of business or pursuant to a provision of law.
- (e)(1) Notwithstanding the requirements of the clauses in paragraphs (a), (b), (c), and (d) of this clause, the Contractor is not required to flow down any FAR clause, other than those in this paragraph (e)(1) in a subcontract for commercial items. Unless otherwise indicated below, the extent of the flow down shall be as required by the clause—
- (i) [52.203-13](#), Contractor Code of Business Ethics and Conduct (Oct 2015) ([41 U.S.C. 3509](#)).
  - (ii) [52.203-19](#), Prohibition on Requiring Certain Internal Confidentiality Agreements or Statements (Jan 2017) (section 743 of Division E, Title VII, of the Consolidated and Further Continuing Appropriations Act, 2015 (Pub. L. 113-235) and its successor provisions in subsequent appropriations acts (and as extended in continuing resolutions)).
  - (iii) [52.219-8](#), Utilization of Small Business Concerns (Nov 2016) ([15 U.S.C. 637\(d\)\(2\)](#) and (3)), in all subcontracts that offer further subcontracting opportunities. If the subcontract (except subcontracts to small business concerns) exceeds \$700,000 (\$1.5 million for construction of any

public facility), the subcontractor must include [52.219-8](#) in lower tier subcontracts that offer subcontracting opportunities.

(iv) [52.222-17](#), Nondisplacement of Qualified Workers (May 2014) (E.O. 13495). Flow down required in accordance with paragraph (l) of FAR clause [52.222-17](#).

(v) [52.222-21](#), Prohibition of Segregated Facilities (Apr 2015)

(vi) [52.222-26](#), Equal Opportunity (Sept 2016) (E.O. 11246).

(vii) [52.222-35](#), Equal Opportunity for Veterans (Oct 2015) ([38 U.S.C. 4212](#)).

(viii) [52.222-36](#), Equal Opportunity for Workers with Disabilities (Jul 2014) ([29 U.S.C. 793](#)).

(ix) [52.222-37](#), Employment Reports on Veterans (Feb 2016) ([38 U.S.C. 4212](#))

(x) [52.222-40](#), Notification of Employee Rights Under the National Labor Relations Act (Dec 2010) (E.O. 13496). Flow down required in accordance with paragraph (f) of FAR clause [52.222-40](#).

(xi) [52.222-41](#), Service Contract Labor Standards (May 2014) ([41 U.S.C. chapter 67](#)).

(xii)

[52.222-50](#), Combating Trafficking in Persons (Mar 2015) ([22 U.S.C. chapter 78](#) and E.O 13627). Alternate I (Mar 2015) of [52.222-50](#) ([22 U.S.C. chapter 78](#) and E.O 13627).

(xiii) [52.222-51](#), Exemption from Application of the Service Contract Labor Standards to Contracts for Maintenance, Calibration, or Repair of Certain Equipment-Requirements (May 2014) ([41 U.S.C. chapter 67](#)).

(xiv) [52.222-53](#), Exemption from Application of the Service Contract Labor Standards to Contracts for Certain Services-Requirements (May 2014) ([41 U.S.C. chapter 67](#)).

(xv) [52.222-54](#), Employment Eligibility Verification (Oct 2015) (E.O. 12989).

(xvi) [52.222-55](#), Minimum Wages Under Executive Order 13658 (Dec 2015).

(xvii) [52.222-59](#), Compliance with Labor Laws (Executive Order 13673) (Oct 2016) (Applies at \$50 million for solicitations and resultant contracts issued from October 25, 2016 through April 24, 2017; applies at \$500,000 for solicitations and resultant contracts issued after April 24, 2017).

**Note to paragraph (e)(1)(xvii):** By a court order issued on October 24, 2016, 52.222-59 is enjoined indefinitely as of the date of the order. The enjoined paragraph will become effective immediately if the court terminates the injunction. At that time, GSA, DoD and NASA will publish a document in the Federal Register advising the public of the termination of the injunction.

(xviii) [52.222-60](#), Paycheck Transparency (Executive Order 13673) (Oct 2016)).

(xix) [52.222-62](#), Paid Sick Leave Under Executive Order 13706 (Jan 2017) (E.O. 13706).

(xx)(A) [52.224-3](#), Privacy Training (Jan 2017) (5 U.S.C. 552a).

(B) Alternate I (Jan 2017) of [52.224-3](#).

(xxi) [52.225-26](#), Contractors Performing Private Security Functions Outside the United States (Oct 2016) (Section 862, as amended, of the National Defense Authorization Act for Fiscal Year 2008; [10 U.S.C. 2302 Note](#)).

(xxii) [52.226-6](#), Promoting Excess Food Donation to Nonprofit Organizations (May 2014) ([42 U.S.C. 1792](#)). Flow down required in accordance with paragraph (e) of FAR clause [52.226-6](#).

(xxiii) [52.247-64](#), Preference for Privately Owned U.S.-Flag Commercial Vessels (Feb 2006) ([46 U.S.C. Appx. 1241\(b\)](#) and [10 U.S.C. 2631](#)). Flow down required in accordance with paragraph (d) of FAR clause [52.247-64](#).

(2) While not required, the Contractor may include in its subcontracts for commercial items a minimal number of additional clauses necessary to satisfy its contractual obligations.

**Agency Contact Information**  
**BLM, BIA, NPS, FWS**

**BLM (BID, BUD, MCD, LED)**

Sarah Lee  
1299 Rimtop Drive  
Billings, MT 59101  
406-896-2915  
[sjlee@blm.gov](mailto:sjlee@blm.gov)

**BIA - Rocky Mountain Region (BFA, CRA, FBA, FPA, NCA, RBA)**

Amanda Boatright  
2021 4th Avenue North  
Billings, MT 59101  
406-247-7949  
[amanda.boatright@bia.gov](mailto:amanda.boatright@bia.gov)

**NPS - Glacier National Park (GNP)**

Biddy Simet  
PO Box 128  
West Glacier, MT 59936  
406-888-5806  
[biddy\\_simet@nps.gov](mailto:biddy_simet@nps.gov)

**BIA -Northwest Region (FHA)**

Kevin Kelly  
911 Northeast 11th  
Portland, OR 97232  
503-231-2279  
[kevin.kelly@bia.gov](mailto:kevin.kelly@bia.gov)

**NPS - Yellowstone National Park (YNP)**

Georgia McAdams  
PO Box 168  
Yellowstone National Park, WY 82190-1068  
307-344-2196  
[georgia\\_mcadams@nps.gov](mailto:georgia_mcadams@nps.gov)

**FWS Fish and Wildlife Service**

Mike Granger  
333 Airport Rd.  
Lewistown, MT. 59457  
406-535-2800, ext. 15

**USFS**

**Lolo (LNF) & Bitterroot (BRF) National Forests**

Deanna Crawford  
1801 North 1st Street  
Hamilton, MT 59840  
406-363-7135  
[dcrawford02@fes.fed.us](mailto:dcrawford02@fes.fed.us)

**Helena (HNF), Lewis & Clark (LCF) , Beaverhead Deerlodge (BDF) National Forests**

Lily Huskey  
1101 15th Street North  
Great Falls, MT 59401  
406-868-7428  
[lhsuskey@fs.fed.us](mailto:lhsuskey@fs.fed.us)

**Kootenai (KNF) & Flathead (FNF) National Forests**

Terri Tangen  
31374 HWY 2  
Libby, MT 59923  
406-283-7650  
[ttangen@fs.fed.us](mailto:ttangen@fs.fed.us)

**Custer Gallatin (CGF) National Forests**

Joyce Anderson  
1310 Main Street  
Billings, MT 59105  
406-690-4541  
[jnanderson@fs.fed.us](mailto:jnanderson@fs.fed.us)

**Idaho Panhandle (IPF) , Nez Perce-Clearwater (NCF) National Forests**

Heather Good  
104 Airport Road  
Grangeville, ID 83530  
208-983-4096  
[hjgood@fs.fed.us](mailto:hjgood@fs.fed.us)

## STATES

### **IDAHO (ID)**

Wendy Walter or Debbie Godfrey  
3284 West Industrial Loop  
Coeur d'Alene, ID 83815  
208-769-1525  
[wwalter@idl.idaho.gov](mailto:wwalter@idl.idaho.gov) or [dgodfrey@idl.idaho.gov](mailto:dgodfrey@idl.idaho.gov)

### **MONTANA (SWS, NWS, CES, NES, SLO, EAS)**

Joanne Marceau  
2705 Spurgin Road  
Missoula, MT 59804  
406-542-4252  
[jmarceau@mt.gov](mailto:jmarceau@mt.gov)

### **NORTH DAKOTA (NDS)**

Anthony Schultz (Acting)  
916 East Interstate Avenue, Ste 4  
Bismarck, ND 58503  
701-328-9916 or 701-425-1835  
[Anthony.Schultz@ndsu.edu](mailto:Anthony.Schultz@ndsu.edu)

## **Idaho Department of Lands Office Locations**

### **Cataldo**

[Bob](#) Burke – Area Supervisor  
80 Hilltop Overpass Road  
Kingston, ID 83839.  
Phone: (208) 682-4611  
Fax: (208) 682-2991  
Len Young  
Kjell Truesdell

### **Ponderosa**

[Sam](#) Charles - Area Supervisor  
3130 Highway 3  
Deary, ID 83823  
Phone: (208) 877-1121  
Fax: (208) 877-1122.  
[Roger Kechter](#)  
Jason Svancara

### **Craig Mountain**

Thom Hawkins - Area Supervisor  
PO Box 68  
Craigmont ID 83523  
Phone: (208) 924-5571  
Fax: (208) 924-5571  
Tim Tevebaugh

### **Priest Lake**

[Mick Schanilec](#) – Area Supervisor  
4053 Cavanaugh Bay Road  
Coolin, ID 83821  
Phone: (208) 443-2516  
Fax: (208) 443-2162  
Dan Brown

### **Eastern Idaho**

Pat Brown – Area Supervisor  
3563 Ririe Highway  
Idaho Falls, ID 83401.  
Phone: (208) 525-7167  
Fax: (208) 525-7178.

### **South Central**

Tim Duffner - Area Supervisor  
PO Box 149  
Gooding, ID 83330  
Phone: (208) 934-5606  
Fax: (208) 934-5362

### **Kootenai Valley**

Scott Bacon – Area Supervisor  
Route 4, Box 4810  
Bonners Ferry, ID 83805.  
Phone: (208) 267-5577  
Fax: (208) 267-8301  
Eric Haase  
Chris Lund

### **Southwest**

Steve Douglas – Area Supervisor  
8355 West State Street  
Boise, ID 83703.  
Phone: (208) 334-3488  
Fax: (208) 853-6372.  
Dan Christman  
Roy Peckham

**Maggie Creek**

Jim Clapperton - Area Supervisor  
Route 2 Box 190  
Kamiah, ID 83536  
Phone: (208) 935-2141  
Fax: (208) 935-0905  
Dave Summers  
Chris Gerhart

**Mica**

[Mike Denney](#) – Area Supervisor  
3706 Industrial Avenue S.  
Coeur d'Alene, ID 83815.  
Phone: (208) 769-1577  
Fax: (208) 769-1597.  
Gary Darrington

**Pend Oreille Lake**

Ed Robinson – Area Supervisor  
2550 Highway 2 West  
Sandpoint, ID 83864.  
Phone: (208) 263-5104  
Fax: (208) 263-0724.  
Chris Remsen

**St. Joe**

Ken Okfen – Area Supervisor  
1806 Main Avenue  
St. Maries, ID 83861.  
Phone: (208) 245-4551  
Fax: (208) 245-4867  
John Pollard

**Clearwater-Potlatch Timber  
Protective Assn.**

Howard Weeks – Chief Fire  
Warden  
10250 Highway 12, Orofino, ID  
83544  
Phone: (208) 476-5612  
Fax: (208) 476-7218  
Kevin Korbel  
John Cunningham

**Southern Idaho Timber  
Protective Assn.**

Mark Woods – Fire Warden  
555 Deinhard Lane, McCall ID  
83638  
Phone: (208) 634-2268  
Fax: (208) 634-5117  
Tom Binde

## MEMO OF UNDERSTANDING (MOU) HOLDERS AND PUBLIC EDUCATION PROVIDERS

Available to All

To assure sufficient wildland fire training and personnel and equipment inspection opportunities are available for private sector contractors who participate in this solicitation, and that this training meets or exceeds National Wildfire Coordination Group (NWCG) standards, and the personnel and equipment inspections meets or exceeds the specifications as stated in Northern Rockies Geographic Area solicitations, the Northern Rockies Coordination Group (NRCG) has entered into memorandums of understanding (MOUs) with individuals, companies, contractor associations and public education providers. The list of valid MOUs with NRCG is available at: <http://www.fs.fed.us/r1/fire/nrcg/>

Other Geographic areas may have similar training MOUs or sources for qualifications. Training certificates, work capacity tests, position task books, and/or incident qualifications cards (Red Cards) from these approved providers will be recognized.

If equipment and or personnel inspections are required, only equipment and/or personnel certifications from valid NRCG MOU inspection holders will be recognized and accepted as submittals for any Northern Rockies Geographic Area solicitations.

## **Definitions & Abbreviations**

The specific meanings of terms used in this specification may be found in the Glossary of Terms of the Fireline Handbook, NWCG Handbook 3; PMS 410-1; NFES 0065, and any other prevailing current NWCG publication unless otherwise defined herein:

**AGENCY:** See "Government".

**AGENCY COOPERATOR:** Local Government entities available through agreement to assist the Federal and State Government agencies.

**AGREEMENT:** References the Blanket Purchase Agreement documented on the SF-1449/OF-294, and its attachments.

**CAMPSITE:** Any area designated by the Government where there are facilities in support of an incident.

**CO:** Contracting Officer

**COR:** Contracting Officer's Representative- GOVERNMENT agent/employee responsible for assisting in the administration of the agreement and who has been designated by the Contracting Officer (CO).

**DESIGNATED DISPATCH POINT (DDP):** Physical address where the resource is located

**FS:** Forest Service

**FMCSA:** Federal Motor Carrier Safety Administration

**GACC:** Geographic Area Coordination Center

**GAWR:** Gross Axle Weight Rating

**GOVERNMENT:** United States Department of Agriculture - Forest Service (USDA-FS), National Park Service (NPS), Bureau of Land Management (BLM), Bureau of Indian Affairs (BIA), and United States Fish & Wildlife Service (USF&WS), Federal Emergency Management Agency (FEMA) Put Cooperators (States) in here

**GOVERNMENT REPRESENTATIVE:** Those employees of the agencies listed under the definition of Government that have a designation in writing, or are designated by their position.

**GVAW:** Gross Vehicle Axle Weight

**GVWR:** Gross Vehicle Weight Rating

**HOST DISPATCH CENTER:** Interagency dispatch center responsible for dispatching resources under this agreement

**HOST DISPATCH ZONE:** Geographic area defined by the Host Dispatch Center's area of authority.

**ICS:** Incident Command System

**IIBMH:** Interagency Incident Business Management Handbook

**INCIDENT:** An occurrence or event, either human-caused or natural phenomena, that requires action by emergency service personnel to prevent or minimize loss of life or damage to property and/or natural resources.

**INITIAL ATTACK:** A planned response to a wildfire given the wildfire's potential fire behavior. The objective of initial attack is to stop the spread of the wildfire and suppress it at least cost. An aggressive suppression action that is consistent with firefighter and public safety.

**ON SHIFT:** Includes time worked, time that equipment is held or directed to be in a state of readiness, and compensable travel (equipment traveling under its own power) that has a specific start and ending time.

**OPERATIONAL PERIOD:** Equal to one shift, an operational period is defined by the incident action plan.

**ORDINARY WEAR AND TEAR:** Equipment furnished under this agreement may be operated and subjected to extreme environmental and/or strenuous operating conditions, which could include but is not limited to unimproved roads, steep, rocky, hilly terrain, dust, heat, and smoky conditions. As a result, by entering into this agreement, the contractor agrees that what is considered wear and tear under this agreement is in excess of what the equipment is subjected to under normal operations and is reflected in the rates paid for the equipment.

**POINT OF HIRE:** Contractor's place of business, or where the resource is located, at the time of dispatch.

**POINT OF RELEASE:** The location from which a contractor is released upon expiration or termination of required services. This point may be the same as the point of hire.

**PROPERTY:** (Use definition in Interagency Incident Business Management Handbook)

1. **Accountable Property.** Items with a purchase price of \$5,000 (USDA, USDI) or more, or items that the incident agency considers sensitive, such as cameras, computers, chainsaws, and radios, are accountable and are marked with an agency identification number.
2. **Durable Property.** Durable properties are those non-accountable items that have a useful life expectancy greater than one incident (e.g., sleeping bags, water handling accessories,

tents, headlamps, tools). This property may be marked with paint or etching to show "US GOVT", or an agency specific marking.

3. **Consumable Goods.** Consumable goods are items normally expected to be consumed on the incident (e.g., batteries, Meals Ready to Eat, plastic canteens, petroleum products). This property is not marked.

**RON:** Remain Over Night

**ROSS:** Resource Ordering and Status System

**SAM:** System for Award Management (formally CCR-Contractors Registration)

**SEVERITY:** The class of assignments that are related to pre-suppression activities. Examples of appropriate severity activities may include but not limited to standby at the host unit, limited patrol, tool sharpening, or other activities that do not unduly interfere with fire readiness and a 10-minute mobilization response time. Increase the level of pre-suppression capability and fire preparedness when predicted or actual burning conditions exceed those normally expected, due to severe weather conditions.

**SUPPRESSION:** All the work of extinguishing or confining a fire beginning with its discovery

**UNDER HIRE:** Refer to C.21.8(2) (Statement of Work)

**WORK/REST:** Refer to C.6.7. (Statement of Work)

## Federal Payment Offices

### USDA Forest Service

USDA Forest Service  
Albuquerque Service Center  
Incident Business  
101B Sun Ave. NE  
Albuquerque, NM 87109

### National Park Service

National Park Service Accounting  
Operations Center  
P.O. Box 100000  
13461 Sunrise Valley Drive  
Herndon, VA 20171

### US Fish and Wildlife Service

U.S. Fish and Wildlife Service  
Attn: RFMC David Carter  
134 Union Boulevard, Suite 300  
Lakewood, CO 80228

### Bureau of Land Management

BLM-Bureau of Land Management  
Billings State Office  
Support Services  
5001 Southgate Dr.  
Billings, MT. 59101

### Bureau of Indian Affairs

Reston Fiscal Services  
12220 Sunrise Valley Dr.  
Herndon, VA. 20191

## State of Idaho – Payment Offices

### Cataldo

80 Hilltop Overpass Road  
Kingston, ID 83839.  
Phone: (208) 682-4611  
Fax: (208) 682 2001

### Craig Mountain

PO Box 68  
Craigmont ID 83523  
Phone: (208) 924-5571  
Fax: (208) 924 5571

### Eastern Idaho

3563 Ririe Highway  
Idaho Falls, ID 83401.  
Phone: (208) 525-7167  
Fax: (208) 525-7178

### Kootenai Valley

Route 4, Box 4810  
Bonners Ferry, ID 83805.  
Phone: (208) 267-5577  
Fax: (208) 267 8201

### Mica

3706 Industrial Avenue S.  
Coeur d'Alene, ID 83815.  
Phone: (208) 769-1577  
Fax: (208) 760 1507

### Pend Oreille Lake

2550 Highway 2 West  
Sandpoint, ID 83864.  
Phone: (208) 263-5104  
Fax: (208) 263 0721

### Ponderosa

3130 Highway 3  
Deary, ID 83823  
Phone: (208) 877-1121  
Fax: (208) 877-1122

### Priest Lake

4053 Cavanaugh Bay Road  
Coolin, ID 83821  
Phone: (208) 443-2516  
Fax: (208) 443 2162

**Maggie Creek**  
Route 2 Box 190  
Kamiah, ID 83536  
Phone: (208) 935-2141  
Fax: (208) 935-0905

**Southwest**  
8355 West State Street  
Boise, ID 83703.  
Phone: (208) 334-3488  
Fax: (208) 853-6372

**St. Joe**  
1806 Main Avenue  
St. Maries, ID 83861.  
Phone: (208) 245-4551  
Fax: (208) 245-4867

**South Central**  
PO Box 149  
Gooding, ID 83330  
**Phone:** (208) 934-5606  
**Fax:** (208) 934-5362

**Clearwater-Potlatch Timber Protective Assn.**  
10250 Highway 12, Orofino, ID 83544  
Phone: (208) 476-5612  
Fax: (208) 476-7218

**Southern Idaho Timber Protective Assn.**  
555 Deinhard Lane, McCall ID 83638  
Phone: (208) 634-2268  
Fax: (208) 634-5117

**State of North Dakota – Payment Office**

**State Foresters Office**  
307 First Street East  
Bottineau, ND 58318  
Attn: Brenda Johnson  
(701) 228-5422

**State of Montana**  
**Department of Natural Resources and Conservation**

**DNRC Forestry Division**  
2705 Spurgin Rd.  
Missoula MT 59804

**DNRC Southwestern Land Office**  
1401 27th Ave  
Missoula MT 59804

**DNRC Central Land Office**  
8001 N Montana Ave  
Helena MT 59602

**DNRC Northeastern Land Office**  
PO Box 1021  
Lewistown MT 59457

**DNRC Eastern Land Office**  
PO Box 1794  
Miles City MT 59301

**DNRC Southern Land Office**  
Airport Industrial Park  
1371 Rintop Drive  
Billings MT 59105-1978

**DNRC Northwestern Land Office**  
655 Timberwolf Parkway STE 2  
Kalispell MT 59901-1215

**Fuel Tender Checklist - Pre-Award Inspection**

**Company Name:** \_\_\_\_\_

**Phone Number/s (Main Contact):** (\_\_\_\_) \_\_\_\_\_

**Address:** \_\_\_\_\_

**City:** \_\_\_\_\_ **State:** \_\_\_\_\_ **Zip Code:** \_\_\_\_\_

**Equipment:**

Type I (2500+ gallons)     Type II (1500 – 2499 gallons)     Type III (1000- 1499 gallons)

**Vin Number:** \_\_\_\_\_ **US DOT**  
**Number:** \_\_\_\_\_

**License Number:** \_\_\_\_\_

**Make:** \_\_\_\_\_ **Model:** \_\_\_\_\_ **Year:** \_\_\_\_\_

<b>Required items checklist</b>	<b>Yes</b>	<b>No</b>
<b>Attached Copy</b> of the completed OF-296 Form		
<b>GAWR/GVWR</b> posted on the vehicle		
<b>Fuel Tank</b> – <input type="checkbox"/> 306 or <input type="checkbox"/> 406 spec tank		
<b>Fuel Tanks Inspection</b> current on yearly Visual & Leakage (VK) test		
<b>Fuel Tank Inspection</b> current on Internal & Pressure (I&P) with the last five (5) years		
<b>Values:</b> All tank control valves shall be protected by an emergency shut off valve Handles should be painted red or decal should direct the user to the emergency valve All valves should shut completely with leaking fuel Tanks Control valves equipped with fusible nuts		
<b>Wiring:</b> All tank control valves shall be protected by an emergency shutoff valve. Handles should be painted red or a decal should direct the user to the emergency valve. All valves should shut completely with no leaking fuel Tank control valves equipped with fusible nuts		
<b>Hoses and Nozzles:</b> All hoses shall be in good condition with no deep cracks or leaking surfaces Nozzles shall be of proper size for dispensing fuel Large nozzle for Diesel Small for unleaded Hoses shall be in good condition with no deep cracks or leaking surfaces		
Bonded hose reel and or a ground rod and cable for grounding the tender while fueling.		
<b>Certified meter</b> to measure accurate devices		
<b>Placarding</b> – Properly placarded for product being carried		
<b>A fire extinguisher</b> , multi-purpose 2A 10BC that is securely mounted to the		

vehicle and accessible by the operator. The fire extinguisher shall have a current annual inspection tag and the annual maintenance tag in regards to a 6 year annual inspection and every 12 years regarding a hydro test on all dry powder, metal fire extinguishers.		
<b>Fuel Response Kit</b> , along with Current Edition of Hazardous Materials Compliance Pocketbook and Emergency Response Guidebook in conjunction with load sheets and MSDS Sheets		
<b>Federal Hazardous Material Endorsement and/or State Hazardous Material Endorsement</b> (if required)		
<b>Fire Extinguisher</b> – Mult-purpose 2A:10BC securely mounted to the vehicle and accessible by the operator		
<b>Chock Blocks</b> ( 2 each required)		
<b>Flashlight</b> (Minimum of 2 “D” Battery)		
<b>Back up Alarm</b> – 87 decibel or greater measured at five (5) feet behind and in the center of the equipment		
<b>Tires, including spare if required</b> – Minimum tread depth of 4/32 on the steering axle and 2/32 on the rear. Spare tire if required a minimum of 4/32		
<b>Vehicles cleaned</b> to reduce weed seed spread		
<b>Seat belts</b> available for driver and any passengers.		

**Inspector Signature:** \_\_\_\_\_ **Date:** \_\_\_\_\_

**Contractor Signature:** \_\_\_\_\_ **Date:** \_\_\_\_\_

## **HARASSMENT FREE WORKPLACE POLICY**

**POLICY:** The National policy states: The Forest Service will not tolerate harassment based on race, national origin, religion, age, mental or physical disability, color, sex, or any other non-merit factors. The Forest Service strives for a harassment-free work environment where people treat one another with respect. Managers, supervisors, and all employees, as well as our contractors, cooperators and volunteers have the primary responsibility for creating and sustaining this harassment-free environment (by example, by job supervision, by coaching, by training, by contract enforcement, and by other means). All employees, contractor personnel, and visitors must take personal responsibility for maintaining conduct that is professional and supportive of this environment.

**ACTION REQUIRED:** Managers and supervisors must take immediate action to stop harassment (or any other inappropriate behavior), to protect the people targeted and to take all reasonable steps to ensure that no further harassment or retaliation occurs. Employees who witness harassment should report it to the proper authority.

**LOCATIONS COVERED:** The contractors work environment covers any area where employees work or where work-related activities occur including travel. This includes field sites, incident bases, staging areas, firelines, government buildings and other facilities such as fitness centers and campgrounds. Also included are vehicles or other conveyances used for travel.

**WHAT HARASSMENT IS:** Harassment is coercive or repeated, unsolicited and unwelcome verbal comments, gestures or physical contacts and includes retaliation for confronting or reporting harassment. Examples of harassment include, but are not limited to, the following:

Physical conduct: Unwelcome touching, standing too close, inappropriate or threatening staring or glaring, obscene, threatening, or offensive gestures.

Verbal or written conduct: Inappropriate references to body parts, derogatory or demeaning comments, jokes, or personal questions; sexual innuendoes; offensive remarks about race, gender, religion, age, ethnicity, sexual orientation, political beliefs, marital status, or disability; obscene letters or telephone calls; catcalls; whistles; sexually suggestive sounds; loud, aggressive, inappropriate comments or other verbal abuse.

Visual, Graphic or Pictorial Displays: Display of nude pictures, scantily-clad, or offensively-clad people; display of intimidating or offensive religious, political, or other symbols; display of offensive, threatening, demeaning, or derogatory drawings, cartoons, or other graphics; offensive T-shirts, coffee mugs, bumper stickers in locations covered above or other articles. Individuals who believe they are being harassed or retaliated against should exercise any one or more of the following options as soon as possible:

Tell the harasser to stop the offensive conduct; and/or Tell a manager or supervisor about the conduct; and/or Contact your Procurement Unit Leader, Contracting Officer, a special Emphasis Program Manager, or any other individual you trust who would take action.

In addition, you may seek help from: Civil Rights Enforcement And Adjudication your local Employee Assistance Program office, or the Regional Office Employee Relations Group.

# **Idaho Department of Lands Standard Terms & Conditions**

## **1. CONTRACT RELATIONSHIP**

It is distinctly and particularly understood and agreed between the parties that this contract does not create an employer/employee relationship. Furthermore, the State of Idaho is in no way associated or otherwise connected with the performance of any service under this contract on the part of the Contractor or with the employment of labor or the incurring of expenses by the Contractor. Said Contractor is an independent contractor in the performance of each and every part of this contract, and solely and personally liable for all labor, taxes, insurance, required bonding and other expenses, except as specifically stated herein, and for any and all damages in connection with the operation of this contract, whether it may be for personal injuries or damages of any other kind. The Contractor shall exonerate, indemnify and hold the State of Idaho harmless from and against and assume full responsibility for payment of all federal, state and local taxes or contributions imposed or required under unemployment insurance, social security, and income tax laws with respect to the Contractor or Contractor's employees engaged in performance under this contract.

## **2. CONTRACTOR RESPONSIBILITY**

The Contractor shall be required to assume responsibility for production and delivery of all material and services included in this contract, whether or not the Contractor is the manufacturer or producer of such material or services. Further, the Contractor will be the sole point of contact on contractual matters, including payment of charges resulting from the use or purchase of goods or services.

## **3. SUBCONTRACTING**

Unless otherwise allowed by the State in this contract, the Contractor shall not, without written approval from the State, enter into any subcontract relating to the performance of this contract or any part thereof. Approval by the State of Contractor's request to subcontract or acceptance of or payment for subcontracted work by the State shall not in any way relieve the Contractor of responsibility for the professional and technical accuracy and adequacy of the work. The Contractor shall be and remain liable for all damages to the State caused by negligent performance or non-performance of work under the contract by Contractor's subcontractor or its sub-subcontractor.

## **4. INSURANCE**

Prior to the commencement of work under this contract, and until all work specified herein is completed, the Contractor shall maintain in effect all insurance as set forth below and shall comply with all limits, terms and conditions stipulated within the insurance policy(ies). Contractor shall provide the Idaho Department of Lands with a Certificate of Insurance verifying such coverage. Work under the contract shall not commence until evidence of all required insurance is provided to the State.

a. The Contractor shall maintain and pay for any applicable worker's compensation insurance and will provide a certificate of same.

b. The Contractor shall obtain and retain in force for the duration of this contract, the following forms of insurance written by an insurance company having a Best's rating of AV or better and be licensed and admitted in Idaho. The Contractor shall furnish the Department of Lands with a certificate of insurance executed by a duly authorized representative of each insurer, showing compliance with the insurance requirements set forth below. All certificates shall provide for ten (10) days' written notice to the Department of Lands prior to cancellation or material change of any insurance referred to therein. All policies required shall be written such that the insurance of the Contractor is primary and any insurance carried by the State of Idaho, its departments, agents, officials, and employees shall be excess and not contributory to the insurance provided by the Contractor. All policies shall be endorsed to include the State of Idaho, its departments, agents, officials, and employees as additional insureds and shall protect the Contractor and the State from claims for damages for bodily injury, including accidental death, as well as for claims for property damages, which may arise from operations under this contract whether such operations be by the Contractor, his employees, subcontractors, agents, or guests. All policies shall contain waiver of subrogation coverage or endorsements. Failure of the Department of Lands to demand such certificate(s) or other evidence of full compliance with these insurance requirements or failure of the Department of Lands to identify a deficiency from evidence that is provided shall not be construed as a waiver of Contractor's obligation to maintain such insurance. Failure to maintain the required insurance may result in termination of this contract. The Contractor shall provide certified copies of all insurance policies required within ten (10) days if requested by the Department of Lands.

i. Commercial General and Umbrella Liability Insurance

Contractor shall maintain commercial general liability (CGL) and, if necessary, commercial umbrella insurance with a combined single limit of not less than \$1,000,000 each occurrence. The CGL shall be written on standard ISO occurrence form (or a substitute form providing equivalent coverage) and shall cover liability arising from premises, operations, independent contractors, products-completed operations, personal injury, advertising injury, and liability assumed under an insured contract including the tort liability of another assumed in a business contract.

ii. Aircraft/Aerial Operations Liability Insurance

Contractor shall maintain aircraft/aerial operations liability insurance with a combined single limit of not less than \$1,000,000 each occurrence and passenger liability not less than \$100,000 per seat. The policy will provide coverage for bodily injury and property damage arising from any aerial operations engaged in under this contract.

iii. Automobile Insurance

The Contractor shall maintain automobile liability insurance which shall provide a minimum \$500,000 combined single limit per occurrence and shall include coverage for owned, non-owned, and hired automobiles.

c. By requiring insurance herein, the Department of Lands does not represent that coverage and limits will necessarily be adequate to protect Contractor, and such coverage and limits shall not be deemed as a limitation on Contractor's liability under the indemnities granted to the State in this contract.

d. The Contractor shall maintain worker's compensation insurance including employer's liability in the amount required by statute covering employees of Contractor and any uninsured subcontractors. Contractor shall furnish the Department of Lands with a certificate of insurance evidencing such coverage.

e. The Contractor shall require all subcontractors utilized in performance of this contract to provide certificates of insurance to the Department of Lands evidencing insurance coverage with the required additional insured endorsements as set forth in the preceding paragraphs.

## 5. TAXES

If the Contractor is required to pay any taxes incurred as a result of doing business with the State of Idaho, it shall be solely and absolutely responsible for the payment of those taxes.

## 6. LICENSES, PERMITS & FEES

The Contractor shall, without additional expense to the State, obtain all required licenses and permits and pay all fees necessary for executing provisions of this contract unless specifically stated otherwise herein.

## 7. STATE OF IDAHO MINIMUM WAGE LAW

It will be the responsibility of the Contractor to fully comply with Section 44-1502, Idaho Code, regarding minimum wage.

## 8. SAVE HARMLESS

Contractor shall indemnify and hold harmless the State of Idaho from any and all liability, claims, damages, costs, expenses, and actions, including reasonable attorney fees, caused by or that arise from the negligent or wrongful acts or omissions of the Contractor, its employees, agents, or subcontractors under this contract that cause death or injury or damage to property or arising out of a failure to comply with any state or federal statute, law, regulation or act.

## 9. OFFICIALS, AGENTS AND EMPLOYEES OF THE STATE NOT PERSONALLY LIABLE

In no event shall any official, officer, employee or agent of the State of Idaho be in any way personally liable or responsible for any covenant or agreement herein contained whether expressed or implied, nor for any statement, representation or warranty made herein or in any connection with this contract. This section shall not apply to any remedies in law or at equity against any person or entity that exist by reason of fraud, misrepresentation or outside the terms of this contract.

#### 10. RISK OF LOSS

Risk of loss and responsibility and liability for loss or damage will remain with Contractor until final inspection and acceptance when responsibility will pass to the State except as to latent defects, fraud and Contractor's warranty obligations. Such loss, injury or destruction shall not release the Contractor from any obligation under this Contract. If installation is specified in the contract, pricing shall include all charges associated with a complete installation at the location specified.

#### 11. ASSIGNMENTS

The Contractor shall not assign a right or delegate a duty under this contract without the prior written consent of the State.

#### 12. PROHIBITED CONTRACTS

No member of the legislature or officer or employee of any branch of the state government shall directly himself, or by any other person execute, hold or enjoy, in whole or in part, any contract or agreement made or entered into by or on behalf of the state of Idaho, if made by, through or on behalf of the department in which he is an officer or employee or if made by, through or on behalf of any other department unless the same are made after competitive bids. (Idaho Code Section 67-9230(2)).

#### 13. GOVERNMENT REGULATIONS

The Contractor shall abide by and comply with all laws and regulations of the United States, the State of Idaho, counties or other governmental jurisdictions wherein the work is executed insofar as they affect this contract. The Contractor will make all payments, contributions, remittances, and all reports and statements required under said laws.

#### 14. SAFETY INFORMATION

- a. The Contractor assumes full responsibility for the safety of his employees, equipment and supplies.
- b. Contractor guarantees that all items provided by Contractor in performance of this contract meet or exceed those requirements and guidelines established by the Occupational Safety and Health Act, Consumer Product Safety Council, Environmental Protection Agency, or other regulatory agencies

## 15. USE OF THE STATE OF IDAHO NAME

Contractor agrees that it will not, prior to, in the course of, or after performance under this contract, use the State's name in any advertising or promotional media as a customer or client of Contractor without the prior written consent of the State.

## 16. CONTRACT TERMINATION

a. The State may terminate this contract, in whole or part, by written notice delivered to either the Contractor or his representative in any one of the following circumstances.

Termination by the State for cause may result in forfeiture of Contractor's bond if a bond is required under the provisions of this contract.

- (1) Failure of the Contractor to perform any of the provisions of this contract.
- (2) Failure of the Contractor to correct unsatisfactory performance or work within five (5) days after it has been brought to his attention.
- (3) Failure of the Contractor to make satisfactory progress in order to be able to complete the work within the contract period.
- (4) The State may terminate this contract at any time for the convenience of the State upon ten (10) calendar days' written notice specifying the date of termination.

b. Upon termination, the Contractor shall:

- (1) Promptly discontinue performing under the contract, unless the termination notice directs otherwise.
- (2) Promptly return to the State control of the properties and any personal property provided by the State pursuant to the contract.
- (3) If requested by the State, deliver or otherwise make available to the State all data, reports, estimates, summaries and such other information and materials as may have been accumulated by Contractor in performing duties under the contract, whether completed or in process.

c. Upon termination, the obligations and liabilities of the parties shall cease, except that the obligations or liabilities incurred prior to the termination date shall be honored. This paragraph shall not be interpreted to place any requirement on the State to accept or make payment to the Contractor for any incomplete or unsatisfactory work.

d. If the State terminates the contract, the State may take over the work and may award another party a contract to complete the work stated in this contract.

e. In the event of termination, the State shall pay all sums still due Contractor through the effective date of termination in full within thirty (30) days of a written demand and receipt of all items necessary from Contractor to allow the State to make payment.

## 17. APPROPRIATION BY LEGISLATURE REQUIRED

It is understood and agreed that the State is a government entity and this contract shall in no way or manner be construed so as to bind or obligate the state of Idaho beyond the term of any

particular appropriation of funds by the State's Legislature as may exist from time to time. The State reserves the right to terminate this contract in whole or in part (or any order placed under it) if, in its judgment, the Legislature of the state of Idaho fails, neglects, or refuses to appropriate sufficient funds as may be required for the State to continue such payments. All affected future rights and liabilities of the parties hereto shall thereupon cease within ten (10) calendar days after notice to the Contractor. It is understood and agreed that the State's payments herein provided for shall be paid from Idaho State Legislative appropriations and, in some instances, direct federal funding.

#### 18. FORCE MAJEURE

Neither party shall be liable or deemed to be in default for any Force Majeure delay in shipment or performance occasioned by unforeseeable causes beyond the control and without the fault or negligence of the parties, including, but not restricted to, acts of God or the public enemy, fires, floods, epidemics, quarantine, restrictions, strikes, freight embargoes, unusually severe weather, provided that in all cases the Contractor shall notify the State promptly in writing of any cause for delay and the State concurs that the delay was beyond the control and without the fault or negligence of the Contractor. If reasonably possible, the Contractor shall make every reasonable effort to complete performance as soon as possible.

#### 19. GOVERNING LAW

This contract shall be construed in accordance with, and governed by the laws of the State of Idaho.

#### 20. ENTIRE AGREEMENT

This contract, together with all attachments, constitute the entire agreement between the parties with respect to the subject matter hereof and shall supersede all previous discussions, representations, commitments, and all other communications, both oral and written, between the parties.

#### 21. MODIFICATION

This contract may not be released, discharged, changed or modified except by an instrument in writing signed by a duly authorized representative of each of the parties.

**Vendors must complete this and submit as part of the bid packet.**

**Incident Behavior  
Common Responsibilities  
Contractors, Volunteers and Casual Hires**

**Inappropriate Behavior:**

It is extremely important that inappropriate behavior be recognized and dealt with promptly. Inappropriate behavior is all forms of harassment including sexual and racial harassment. Harassment in any form will not be tolerated. When you observe or hear of inappropriate behavior you should:

- Inform and educate subordinates of their rights and responsibilities
  - Tell the harasser to stop the offensive conduct.
- Provide support to the victim.
- Report the incident to your supervisor and the individuals' supervisor, if the behavior continues. Disciplinary action may be necessary.
- Develop appropriate corrective measures.
- Document inappropriate behavior and report it to the appropriate incident manager or agency official.
- While working in and around private property, recognize and respect all private property.

**Drugs and Alcohol:**

- Non-prescription unlawful drugs and alcohol are not permitted at the incident. Possession or use of these substances will result in disciplinary action.
- During off-incident rest periods, personnel are responsible for proper conduct and maintenance of fitness for duty. Drug or alcohol abuse resulting in unfitness for duty will result in disciplinary action.
- Be a positive role model. Do not be involved with drug or alcohol abuse.
- Report any observed drug or alcohol abuse to your supervisor.

I have read and I understand the above described incident behavior responsibilities:

\_\_\_\_\_  
Signature

\_\_\_\_\_  
Date

\_\_\_\_\_  
Company Name

## **Montana Standard Terms & Conditions**

**By submitting a response to this invitation for bid, request for proposal, limited solicitation, or acceptance of a contract, the vendor agrees to acceptance of the following Standard Terms and Conditions and any other provisions that are specific to this solicitation or contract.**

### **STANDARD TERMS AND CONDITIONS REV 08/2016**

**ACCEPTANCE/REJECTION OF BIDS:** The State reserves the right to accept or reject any or all bids, wholly or in part, and to make awards in any manner deemed in the best interest of the State. Bids will be firm for 30 days, unless stated otherwise in the text of the invitation for bid.

**ACCESS AND RETENTION OF RECORDS:** Contractor agrees to provide the department, Legislative Auditor, or their authorized agents, access to any records necessary to determine contract compliance. (Section 18-1-118, MCA). Contractor agrees to create and retain records supporting the services rendered or supplies delivered for a period of eight years after either the completion date of the contract or the conclusion of any claim, litigation, or exception relating to the contract taken by the State of Montana or third party.

**ALTERATION OF SOLICITATION DOCUMENT:** In the event of inconsistencies or contradictions between language contained in the State's solicitation document and a vendor's response, the language contained in the State's original solicitation document will prevail. Intentional manipulation and/or alteration of solicitation document language will result in the vendor's disqualification and possible debarment.

**ASSIGNMENT, TRANSFER AND SUBCONTRACTING:** Contractor shall not assign, transfer or subcontract any portion of the contract without the express written consent of the department. (Section 18-4-141, MCA.)

**COMPLIANCE WITH LAWS:** Contractor shall, in performance of work under this contract, fully comply with all applicable federal, state, or local laws, rules, and regulations, including but not limited to, the Montana Human Rights Act, the Equal Pay Act of 1963, the Civil Rights Act of 1964, the Age Discrimination Act of 1975, the Americans with Disabilities Act of 1990, and Section 504 of the Rehabilitation Act of 1973. The Contractor is the employer for the purpose of providing healthcare benefits and paying any applicable penalties, fees and taxes under the Patient Protection and Affordable Care Act [P.L. 111-148, 124 Stat. 119]. Any subletting or subcontracting by Contractor subjects subcontractors to the same provisions. In accordance with 49-3-207, MCA, Contractor agrees that the hiring of persons to perform this contract will be made on the basis of merit and qualifications and there will be no discrimination based upon race, color, religion, creed, political ideas, sex, age, marital status, physical or mental disability, or national origin by the persons performing this contract.

**CONFORMANCE WITH CONTRACT:** No alteration of the terms, conditions, delivery, price, quality, quantities, or specifications of the contract shall be granted without the State Procurement Bureau's prior written consent. Product or services provided that do not conform to the contract terms, conditions, and specifications may be rejected and returned at Contractor's expense.

**DEBARMENT:** Contractor certifies, by submitting this bid, that neither it nor its principals are presently debarred, suspended, proposed for debarment, declared ineligible, or voluntarily excluded from participation in this transaction (contract) by any governmental department or agency. If Contractor cannot certify this statement, attach a written explanation for review by the State.

**DISABILITY ACCOMMODATIONS:** The State does not discriminate on the basis of disability in admission to, access to, or operations of its programs, services, or activities. Individuals who need aids, alternative document formats, or services for effective communications or other disability related accommodations in the programs and services offered are invited to make their needs and preferences known to this office. Interested parties should provide as much advance notice as possible.

**FAILURE TO HONOR BID/PROPOSAL:** If a bidder to whom a contract is awarded refuses to accept the award (PO/contract) or fails to deliver in accordance with the contract terms and conditions, the department may, in its discretion, suspend the bidder for a period of time from entering into any contracts with the State of Montana.

**FORCE MAJEURE:** Neither party is responsible for failure to fulfill its obligations due to causes beyond its reasonable control, including without limitation, acts or omissions of government or military authority, acts of God, materials shortages, transportation delays, fires, floods, labor disturbances, riots, wars, terrorist acts, or any other causes, directly or indirectly beyond the reasonable control of the nonperforming party, so long as such party uses its best efforts to remedy such failure or delays. A party affected by a force majeure condition shall provide written notice to the other party within a reasonable time of the onset of the condition. In no event, however, shall the notice be provided later than five working days after the onset. If the notice is not provided within the five-day period, then a party may not claim a force majeure event. A force majeure condition suspends a party's obligations under this contract, unless the parties mutually agree that the obligation need not be performed because of the condition.

**HOLD HARMLESS/INDEMNIFICATION:** Contractor agrees to protect, defend, and save the State, its elected and appointed officials, agents, and employees, while acting within the scope of their duties as such, harmless from and against all claims, demands, causes of action of any kind or character, including the cost of defense thereof, arising in favor of Contractor's employees or third parties on account of bodily or personal injuries, death, or damage to property arising out of services performed or omissions of services or in any way resulting from the acts or omissions of Contractor and/or its agents, employees, representatives, assigns, subcontractors, except the sole negligence of the State, under this agreement.

**INTELLECTUAL PROPERTY:** All patents and other legal rights in or to inventions created in whole or in part under the contract must be available to the State for royalty-free and nonexclusive licensing. Both parties shall have a royalty-free, nonexclusive, and irrevocable right to reproduce, publish or otherwise use and authorize others to use, copyrightable property created under the contract.

**PATENT AND COPYRIGHT PROTECTION:** If a third party makes a claim against the State that the products furnished under this purchase order infringe upon or violate any patent or copyright, the State shall promptly notify Contractor. Contractor shall defend such claim in the State's name or its own name, as appropriate, but at Contractor's expense. Contractor shall indemnify the State against all costs, damages, attorney fees, and all other costs and expenses of litigation that accrue as a result of such claim. If the State reasonably concludes that its interests are not being properly protected, or if principles of governmental or public law are involved, it may enter any action.

**PAYMENT TERM:** All payment terms will be computed from the date of delivery of supplies or services OR receipt of a properly executed invoice, whichever is later. Unless otherwise noted in the solicitation document, the State is allowed 30 days to pay such invoices. All contractors will be required to provide banking information at the time of contract execution in order to facilitate State electronic funds transfer payments.

**RECIPROCAL PREFERENCE:** The State of Montana applies a reciprocal preference against a vendor submitting a bid from a state or country that grants a residency preference to its resident businesses. A reciprocal preference is only applied to an invitation for bid for supplies or an invitation for bid for nonconstruction services for public works as defined in section 18-2-401(9), MCA, and then only if federal funds are not involved. For a list of states that grant resident preference, see <http://sfsd.mt.gov/SPB/Preferences>.

**REDUCTION OF FUNDING:** The State must terminate this contract if funds are not appropriated or otherwise made available to support the State's continuation of performance in a subsequent fiscal period. (See section 18-4-313(4), MCA.)

## NORTHERN ROCKIES DISPATCH ZONES AND DISPATCH OFFICES

ID-CDC : Coeur D Alene Dispatch Center, Coeur D Alene, ID, 208-772-3283

ID-GVC; Grangeville Dispatch Center; Grangeville, ID, 208-983-6800

MT-BDC; Billings Dispatch Center, Billings, MT, 406-896-2900

MT-BRC; Bitterroot Dispatch Center, Hamilton, MT, 406-363-7133

MT-BZC; Bozeman Dispatch Center, Bozeman, MT, 406-587-6719

MT-DDC; Dillon Dispatch Center, Dillon, MT, 406-683-3975

MT-GDC; Great Falls Dispatch Center, Great Falls, MT, 406-731-5300

MT-HDC; Helena Dispatch Center, Helena, MT, 406-449-5475

MT-KDC; Kootenai Dispatch Center, Libby, MT, 406-283-7740

MT-KIC; Kalispell Interagency Dispatch Center, Kalispell, MT, 406-758-5260

MT-LEC; Lewistown Dispatch Center, Lewistown, MT, 406-538-1072

MT-MCC; Miles City Dispatch Center, Miles City, MT, 406-233-2900

MT-MDC; Missoula Dispatch Center, Missoula, MT, 406-829-7070

MT-NDC; North Dakota Dispatch Center, Bismarck, ND, 701-333-0260

## NRCG DRUG AND ALCOHOL PROTOCOL FOR CONTRACTED RESOURCES

The use, possession, solicitation for, or sale of narcotics or other controlled substance on Government incidents is prohibited.

Being impaired or under the influence of legal or illegal drugs or alcohol away from the Government incident, if such impairment or influence adversely affects work performance, the safety of the employee or of others is prohibited

If a resource is released from an incident due to violation or suspected violation of drug and alcohol policy as stated, that resource will be statused as unavailable until the submittal of a current drug and alcohol company policy and or current drug and alcohol testing results.

Violation of NRCG Drug and Alcohol Protocols for Contracted resources may result in the suspension or cancellation of this agreement.

# VEHICLE / HEAVY EQUIPMENT SAFETY INSPECTION CHECKLIST

1. INCIDENT NAME / NUMBER	2. ORDER / REQUEST NUMBER
3. OWNER / VENDOR	
4. AGREEMENT, PO, CONTRACT NO.	5. EXPIRES
6. MAKE	7. MODEL, TYPE
8. SERIAL NO. / VIN	9. LICENSE NO.

## 10. PRE-USE INSPECTION

REJECTED

MILES / HRS \_\_\_\_\_ DATE \_\_\_\_\_ TIME \_\_\_\_\_

Inspector Name \_\_\_\_\_ Title \_\_\_\_\_  
Print

ACCEPTED

MILES / HRS \_\_\_\_\_ DATE \_\_\_\_\_ TIME \_\_\_\_\_

Vendor Signature \_\_\_\_\_ Title \_\_\_\_\_  
 Inspector Name \_\_\_\_\_ Title \_\_\_\_\_  
Print

Section I - Tractor, Motor Grader	Pre-use		Release	
	Yes	No	Yes	No
1. ROPS, roll-over protection system: Manufacturer approved system secured to mainframe of tractor. Must include approved seat belts. *				
2. Lights: mounted and working while operating				
3. Battery: check for corrosion, loose terminal, hold downs				
4. Engine running: check oil pressure, knocks and leaks				
5. Gauges: all must be working; oil, temperature, etc. *				
6. Steering clutches: must have 3-4" free travel *				
7. Brakes: must hold at half travel. *				
8. Muffler and spark arrester: approved type unless turboed *				
9. Fuel system: must be free of drips and leaks *				
10. Cooling system: must be free of leaks *				
11. Fan and fan belts: check for defects				
12. Engine supports, equalizer bar, springs, main springs: check shackle bolts, shifted spring leaf *				
13. Hydraulic system: no leaks or drips				
14. Belly plate, rock and radiator guards: securely mounted *				
15. Final drive, transmission and differential: check for dripping				
16. Sprocket and idlers: cracks in spokes, sprocket teeth sharp				
17. Tracks and rollers: grousers height under 1-1/4", loose rollers, broken flanges *				
18. Blade, ripper, winch: operate smoothly and hold at any point				
19. Dozer and assembly: trunnion bolts missing, cracks *				
20. Drawbar: serviceable, safe				
21. Body and cab condition: report dents and damage				

Section IV - Truck, Bus, Van, Pickup	Pre-use		Release	
	Yes	No	Yes	No
1. DOT inspection in the last 12 months: when required *			NA	NA
2. Gauges and lights *				
3. Seat belts *				
4. Glass and mirrors *				
5. Wipers and horn *				
6. Clutch pedal: proper adjustment				
7. Cooling system: check radiator and hoses				
8. Oil level and condition: full and clean				
9. Battery: check for corrosion, loose terminals, hold downs				
10. Fuel system *				
11. Electrical system: generator and starter working				
12. Engine running: check for knocks and leaks				
13. Transmission: check for leaks				
14. Steering *				
15. Brakes *				
16. 4-Wheel drive: check gear boxes, leaks				
17. Drive line U-joints: check for looseness				
18. Springs and shocks *				
19. Differential: check for leaks				
20. Exhaust system *				
21. Frame *				
22. Tire and wheels (List failed position/depth in remarks) *				
23. Body and interior condition: describe and locate damage on back of page 3, Section IV, item 23				
24. Emergency equipment required. * Fire Extinguisher _____ Spare Fuses _____ Reflectors _____				
25. Operator(s) properly licensed. *				

State \_\_\_\_\_ License No. \_\_\_\_\_ Class \_\_\_\_\_  
 Endorsements \_\_\_\_\_ Med.Cert. Expire Date \_\_\_\_\_

### Section II - Remarks

(Describe all unsatisfactory items and identify by line number.)

Section III - Power Saw, Pump	Pre-use		Release	
	Yes	No	Yes	No
1. Visible parts broken *				
2. Visible nuts and bolts tight				
3. Oil in gear case and chain oiler				
4. Cutting bar: straight, chain in good condition *				
5. Exhaust system and spark arrester *				
6. Motor: idles evenly, runs smoothly, satisfactory power				

## 11. RELEASE INSPECTION

NO DAMAGE / NO CLAIM  
Not applicable to buses, inspection required.

MILES / HRS \_\_\_\_\_ DATE \_\_\_\_\_ TIME \_\_\_\_\_

Vendor Signature \_\_\_\_\_ Title \_\_\_\_\_  
 Inspector Name \_\_\_\_\_ Title \_\_\_\_\_  
Print

\* Safety Item - Do not accept until brought into compliance.

## Section IV - Truck, Bus, Van, Pick-up

Motor vehicle parts and accessories must be in Safe Operating Condition At All Times, **FEDERAL MOTOR CARRIER SAFETY REGULATIONS HANDBOOK (FMCSR)** as prescribed by U.S. DEPARTMENT OF TRANSPORTATION **FEDERAL HIGHWAY ADMINISTRATION PARTS 393 & 396**, and **NORTH AMERICAN UNIFORM OUT-OF-SERVICE CRITERIA, COMMERCIAL VEHICLE SAFETY ALLIANCE (CVSA)**.

**REJECT IF:** Parts and accessories covered in FMCSR part 393, 396 and/or CVSA North American Uniform Out-of-Service Criteria are not in safe and proper operating conditions at all times. These include, but are not limited to the parts and accessories listed below.

### 2. Gauges and Lights (393.81, 393.9)

- ♦ Speedometer inoperative.
- ♦ All required lighting devices, reflectors and electrical equipment must be properly positioned, colored and working.

### 3. Seat Belts (393.93)

- ♦ Any driver or right outboard seat belt missing or inoperative.

### 4. Glass and Mirrors (393.60, 393.80)

- ♦ Any discoloration not applied by the manufacturer for reduction of glare.
- ♦ Any windshield crack over 1/4" wide.
- ♦ Any crack less than 1/4" wide that intersects with any other crack.
- ♦ Any damage 3/4" or greater in diameter.
- ♦ Any 2 damaged areas closer than 3" to each other.
- ♦ Any required mirror missing. One on each side, firmly attached to the outside of the vehicle, and so located as to reflect to the driver a view of the highway to the rear along both sides of the vehicle.
- ♦ Any required mirror broken. (396.3(A)(1)).

### 5. Wipers and Horn (393.78, 393.81)

- ♦ Wiper blade(s) fail to clean windshield within 1" of windshield sides.
- ♦ Horn missing, inoperative or fails to give adequate/reliable warning signal.

### 10. Fuel System (393.65, 393.67)

- ♦ Fuel tank not securely attached to vehicle by reason of loose, broken or missing mounting bolts or brackets.
- ♦ Visible leak at any point.
- ♦ Fuel tank cap missing.

### 14. Steering (393.209)

- ♦ Steering wheel does not turn freely, has any spokes cracked through or is missing any parts.
- ♦ Steering lash not within parameters, see chart in FMCSR 393.209.
- ♦ Steering column is not secure.
- ♦ Steering system; any U-joint worn, faulty or repaired by welding.
- ♦ Steering gear box is loose, cracked or missing mounting bolts.
- ♦ Pitman arm is loose, or has any welded repairs.
- ♦ Power Steering; any component is inoperative. Any loose, broken or missing parts. Belts frayed, cracked or slipping.
- ♦ Any fluid leaks, fluid reservoir not full.

### 15. Brakes (393.40-393.53)

- ♦ Brake system has any deficiencies as described in FMCSR.
- ♦ Brake system has any missing, loose, broken, out of adjustment or worn out components.
- ♦ Brake system failure warning device missing, inoperative, or fails to give adequate warning.
- ♦ Brake system has any air or fluid leaks. (396.3(a)(1)).

### 18. Springs and Shocks (393.207)

- ♦ Any axle positioning part is cracked, broken, loose or missing. All axles must be in proper alignment.
- ♦ Any leaf spring cracked, broken, missing or shifted out of position.
- ♦ Adjustable axle assemblies with locking pins missing or not engaged.

### 20. Exhaust (393.83)

- ♦ Any part of the exhaust system so located as would be likely to result in charring, burning, or damaging the wiring, fuel supply or any combustible part of the vehicle.
- ♦ Bus exhaust leaks or discharge forward of the rearmost part of the bus in excess of 6" for Gasoline powered or 15" for other than Gasoline powered, or forward of any door or window designed to be opened on other than a Gasoline powered bus. (Exception: emergency exit)
- ♦ Any leak at any point forward of or directly below the driver and/or sleeper compartment.

### 21. Frame (393.201)

- ♦ Any cracked, broken, loose or sagging frame member.
- ♦ Any loose or missing fasteners including those attaching engine, transmission, steering gear, suspension, body, and fifth wheel.
- ♦ Any condition that causes the body or frame to contact the tire or wheel assemblies. (396.3(a)(1))

### 22. Tires and Wheels (393.75, 393.205)

- ♦ Any body ply or belt material exposed through tread or sidewall.
- ♦ Any tread or sidewall separation.
- ♦ Any cut exposing ply or belt material.
- ♦ Tread depth less than 4/32" on steering axle.
- ♦ Less than 2/32" on any other axle.
- ♦ Any bus with regrooved, recapped, or retreaded tires on the front wheels.
- ♦ Any tire not properly inflated or any overloaded tire.
- ♦ Any tire that comes in contact with any part of the vehicle. (393.3(a)(1))
- ♦ Any tire marked "Not for Highway Use". (393.3(a)(1))
- ♦ Wheels and rims shall not be cracked or broken.
- ♦ Stud or bolt holes on the wheels shall not be elongated.
- ♦ Nuts or bolts shall not be missing or loose.

### 24. Emergency Equipment (393.95)

- ♦ Every power unit must be equipped with a fire extinguisher that is properly filled and readily accessible for use. (393.95(a))
- ♦ At least one spare fuse or other overload protective device. (393.95(c))
- ♦ Warning devices for stopped vehicles. (393.95(f,g))

### 25. License (383.23, 391.41)

- ♦ No person shall operate a commercial motor vehicle unless such person has passed written and driving tests which meet the Federal Standards for the commercial motor vehicle that person operates. (383.23(a))
- ♦ Persons shall not drive a commercial motor vehicle unless he/she is physically qualified to do so and, except as provided in 391.67, has on his/her person the original, or a photographic copy, of a medical examiner's certificate that he/she is physically qualified. (391.41(a))

### IN ADDITION TO THE ABOVE:

Agency personnel reserve the right to reject any equipment due to any additional condition or combination of conditions that make the vehicle unsafe, unreliable, or may pose unreasonable damage to the environment, or will be unable to fully perform the duties for which the equipment has been hired.

The Inspector shall inspect for compliance with the FMCSR, State and Local laws and regulations. Therefore, the Inspector is responsible to ACCEPT or REJECT all equipment he/she inspects.

Section IV, Item 23 - Truck, Bus, Van, Pickup, Body Condition Inspection

Pre-use Inspection

Release Inspection

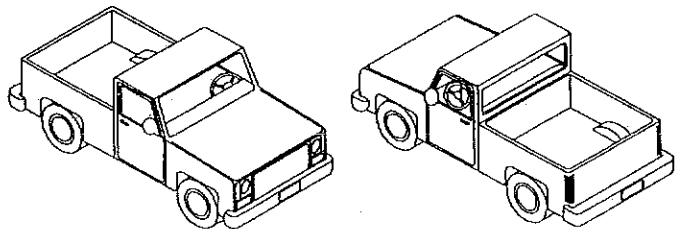
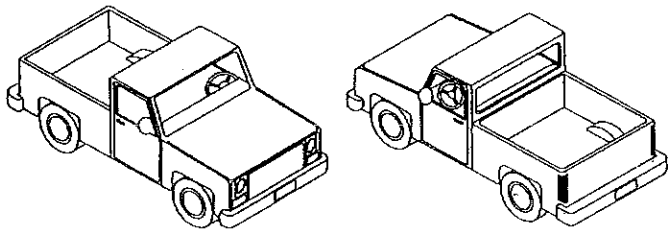
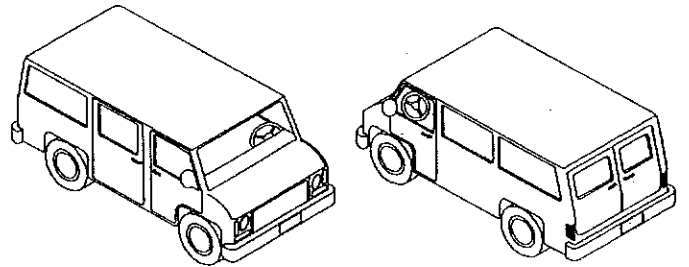
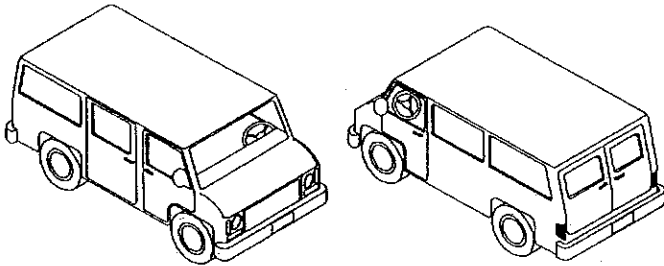
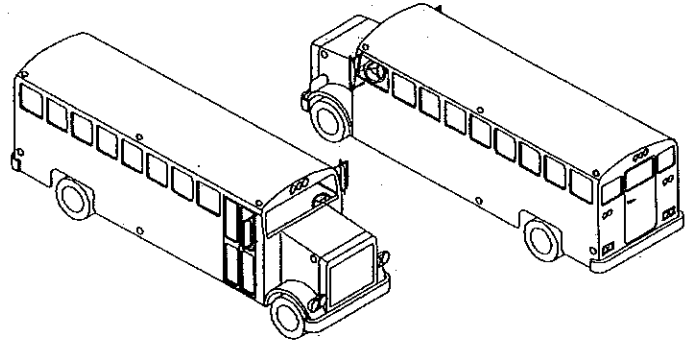
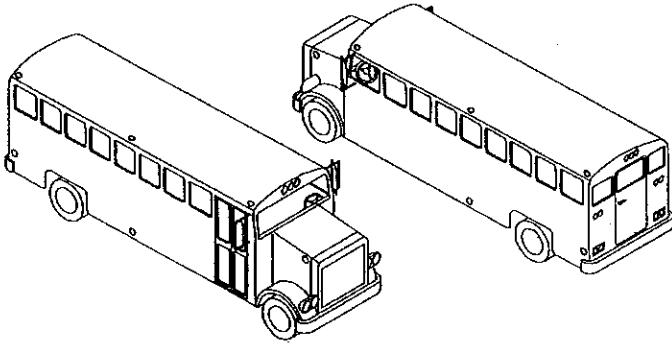
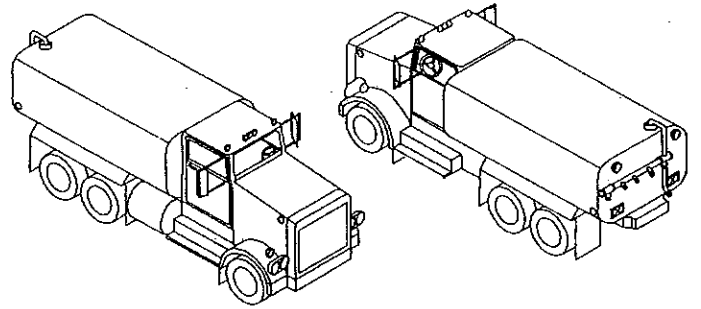
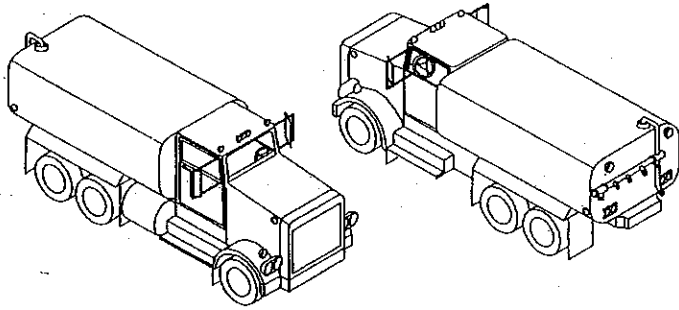

Remarks

# EXAMPLE OF EMERGENCY EQUIPMENT SHIFT TICKET, OF-297

EMERGENCY EQUIPMENT SHIFT TICKET					
NOTE: The responsible Government Officer will update this form each day or shift and make initial and final equipment inspections.				<b>E-16</b>	
1. AGREEMENT NUMBER R4-2-'1567		2. CONTRACTOR (name) JONES EQUIPMENT			
3. INCIDENT OR PROJECT NAME LOSTCREEK		4. INCIDENT NUMBER WIF-2--061		5. OPERATOR (name) PAUL JONES	
6. EQUIPMENT MAKE CATERP11..LAR		7. EQUIPMENT MODEL DOZER, D6C		8. OPERATOR FURNISHED BY <input checked="" type="checkbox"/> CONTRACTOR <input type="checkbox"/> GOVERNMENT	
9. SERIAL NUMBER 47A89876		10. LICENSE NUMBER 4T-89876		11. OPERATING SUPPLIES FURNISHED BY <input checked="" type="checkbox"/> CONTRACTOR (wet) <input type="checkbox"/> GOVERNMENT (dry)	
12. DATE MO/DAYNR	13. EQUIPMENT USE			14. REMARKS (released, down time and cause, problems, et PAUL JONES - OPERATOR	
	START	STOP	HOURS/DAYS/MILES( circle one)		
			WORK		SPECIAL
09115107	0600		12		
					15. EQUIPMENT STATUS <input checked="" type="checkbox"/> a. Inspected and under agreement <input checked="" type="checkbox"/> b. Released by Government <input checked="" type="checkbox"/> c. Withdrawn by Contractor
					16. INVOICE POSTED BY (Recorder's initials)
17. CONTRACTOR'S OR AUTHORIZED AGENT'S SIGNATURE			18. GOVERNMENT OFFICER'S SIGNATURE		19. DATE SIGNED
<i>Sammy Jones - Owner</i>			Sammy Jones – DIV SUP		
NSN 7540-01-119-562850297-102					OPTIONAL FORM 297 1

## **Safety Standards**

**NOTICE:** The following minimum contract standard shall be upheld at all times. The Contracting Officer or appointed representatives (COR) shall consider individuals who cannot meet these minimum requirements UNSAFE and may remove the individual or, if necessary the entire resource from the job site in accordance with the terms of the agreement specification:

### **A. Heat Stress**

There are three forms of heat stress. The mildest is heat cramps. Heat stress can progress to heat exhaustion and eventually heat stroke. Heat stroke is a medical emergency! Delayed treatment can result in brain damage and even death. At the first sign of heat stress, stop work, get into the shade, moreover, begin drinking fluid. See chapter 5 of Fitness and Work Capacity, 2nd ed. (1997). Heat Stress: NFES 1594, PMS-303-1 explains how to detect, treat & prevent heat stress. Cost is 10 cents each.

### **B. Smoke and Carbon Monoxide**

For information on this subject call USDA Forest Service, Technology and Development Program, Publications, (406) 329-3978, and ask for Health hazards of Smoke, Recommendations of the Consensus Conference, April 1997 (Item Number 97512836). Copies are available free of charge in limited numbers.

### **C. “Six Minutes for Safety” Training**

It is recommended that daily Six Minutes for Safety training be conducted that focuses on high risk and low frequency activities that fire personnel may encounter during a fire season. The NWCG website gives information on Six Minutes for Safety, go to [www.nwcg.gov](http://www.nwcg.gov)

### **D. Seat Belts**

Seat belts will be available and used in any vehicle when in motion. It is the operator’s responsibility to ensure compliance.

### **E. Incident Identification/ Qualification Card.**

Personnel shall carry a government (state or federal) picture identification card, such as a driver’s license, passport, state identification card, etc.

### **F. Physical Demands**

The work requires strenuous physical exertion for extended periods including walking, climbing, chopping, throwing, lifting, pulling and frequently carrying objects weighing fifty (50) pounds or more.

### **G. Work/Rest/Driving/ and Length of Assignment Guidelines**

Information on current agency policy on work/rest guidelines, length of assignment, days off and other fire business management information can be found at: [www.nwcg.gov](http://www.nwcg.gov)

# State of Montana Sexual Harassment Policy

1. It is the policy of the Montana Department of Natural Resources and Conservation to prohibit sexual harassment of its employees and applicants for employment in the work place by any person and in any form.
2. Each supervisor has an affirmative duty to maintain the work place free from sexual harassment. This duty includes discussing this policy with all employees and assuring them that they are not required to endure or be subject to insulting, degrading, or offensive sexual treatment.
3. Specifically, sexual harassment refers to behavior which is not welcome, personally offensive, weakens morale and therefore interferes with employees' effectiveness and work environment, and is generally defined as unwelcome sexual advances, requests for favors and other verbal, physical and/or visual contact of a sexual nature when:
  - ❖ Submission is made either explicitly or implicitly a term or condition of an individual's employment.
  - ❖ Submission or rejection by an employee is used as a basis for employment decisions affecting the employee.
  - ❖ Such conduct has the purpose or effect of unreasonably interfering with an employee's work performance or creates an intimidating, hostile, or otherwise offensive work environment.
4. The following are examples of sexual harassment:
  - ❖ Sexual advances which are unwanted (this may include situations which began as reciprocal attractions but later ceased to be reciprocal).
  - ❖ Leering or sexual gestures
  - ❖ Displaying sexually suggestive objects, pictures, cartoons or posters.
  - ❖ Verbal abuse of a sexual nature, sexually oriented jokes, innuendoes, or obscenities
  - ❖ Sexually suggestive letters, notes, or invitations
  - ❖ Reprisals or threats after a negative response to sexual advances
  - ❖ Employment benefits affected in exchange for sexual favors (may include situations where a third party is treated less favorably because others have agreed to sexual advances)
  - ❖ Physical conduct such as assault, attempted rape, impeding or blocking movement or touching
  - ❖ Women in nontraditional work environments may also be subject to hazing (this may include being dared or asked to perform unsafe work practices).
5. No supervisor shall threaten or insinuate either explicit or implied action(s) that an employee's refusal to submit to sexual advances will adversely affect the employee's employment, evaluation, classification (grade), assigned duties, or any other condition of employment or career development.
6. It should be understood that sexual harassment is against the law and the State of Montana is committed to the prevention of all forms of sexual harassment in the work place.

## Standard Contractor Performance Report

Highlighted blocks are required to be completed.

<b>Evaluation Type: Interim _ Final _</b> <i>(check one)</i>			
<b>Evaluating Organization</b> <i>(Fire Name):</i>		<b>Reporting Period: From</b> _____ <b>to</b> _____	
<b>Contracting Office:</b>		<b>Contract Number:</b> _____	<b>Order Number</b> <i>(Resource Order):</i> _____
<b>Contractor Name:</b>		<b>Contractor Address:</b>	
<b>DUNS:</b>		<b>City:</b> _____	<b>State:</b> _____
<b>Additional or Alternate Contractor Name:</b>		<b>Zip/Postal Code:</b> _____	<b>Country:</b> _____
<b>TIN:</b> _____	<b>Industrial Code (NAICS):</b> _____	<b>Commodity Code:</b> _____	<b>Contract Type:</b> _____
<b>Contract Award Date:</b> _____	<b>Contract Expiration Date:</b> _____	<b>Contract Value:</b> _____	
<b>Requirement Description</b> <i>(Equipment Type):</i>			

### Ratings

Summarize contractor performance and check the number which corresponds to the rating for each rating category *(See attached Rating Guidelines)*.

**Quality of Product or Service** *(How did the Contractor perform, document any noncompliance or performance issues)*

<input type="checkbox"/> 0=Unsatisfactory	<input type="checkbox"/> 1=Poor	<input type="checkbox"/> 2=Fair	<input type="checkbox"/> 3=Good	<input type="checkbox"/> 4=Excellent	<input type="checkbox"/> 5=Outstanding
---	---------------------------------	---------------------------------	---------------------------------	--------------------------------------	--

**Government Comments for Quality of Product or Service (2000 characters maximum):**

**Timeliness of Performance** *(Did the Contractor arrive when expected, demob timely; and perform the work in a timely manner)*

<input type="checkbox"/> 0=Unsatisfactory	<input type="checkbox"/> 1=Poor	<input type="checkbox"/> 2=Fair	<input type="checkbox"/> 3=Good	<input type="checkbox"/> 4=Excellent	<input type="checkbox"/> 5=Outstanding
---	---------------------------------	---------------------------------	---------------------------------	--------------------------------------	--

**Government Comments for Timeliness of Performance (2000 characters maximum):**

**Business Relations** *(Did the Contractor perform in a business-like manner; complete administrative requirements timely)*

<input type="checkbox"/> 0=Unsatisfactory	<input type="checkbox"/> 1=Poor	<input type="checkbox"/> 2=Fair	<input type="checkbox"/> 3=Good	<input type="checkbox"/> 4=Excellent	<input type="checkbox"/> 5=Outstanding
---	---------------------------------	---------------------------------	---------------------------------	--------------------------------------	--

**Government Comments for Business Relations (2000 characters maximum):**

## Additional Info

### Contractor Key Personnel

**Contractor Manager/Principal Investigator (Owner's Name):**

**Government Comment on Contractor Manager/Principal Investigator (2000 characters maximum):** *(If applicable, describe working relationship with government representatives for this assignment)*

**Contractor Key Person (Equipment Operator's Name):**

**Government Comment on Contractor Key Person (2000 characters maximum):** *(Describe working relationship with government representatives for this assignment)*

### Customer Satisfaction

**Is/was the contractor committed to customer satisfaction?**  Yes  No *(Check one)*

**Would you recommend the selection of this firm again?**  Yes  No *(Check one)*

**Government Comments on Customer Satisfaction (2000 characters maximum):** *If no to either of above, explain below)*

## Admin Info

**Project Officer/COTR** *(Individual completing the evaluation)*

**Name:** \_\_\_\_\_

**Phone:** \_\_\_\_\_

**Fax:** \_\_\_\_\_

**E-mail Address:** \_\_\_\_\_

**Contractor Representative**

**Name:**

**Phone:**

**Fax:**

**E-mail Address:**

**Alternate Contractor Representative**

**Name:**

**Phone:**

**Fax:**

**E-mail Address:**

**Contracting Officer:**

**Name:**

**Phone:**

**Fax:**

**E-Mail Address:**

## Rating Guidelines

### Quality of Product or Service

**0 = Unsatisfactory 1 = Poor 2 = Fair 3 = Good 4 = Excellent 5 = Outstanding**

Unsatisfactory	Non-conformances are jeopardizing the achievement of contract requirements, despite use of Agency resources. Recovery is not likely. If performance cannot be substantially corrected, it constitutes a significant impediment in consideration for future awards containing similar requirements.
Poor	Overall compliance requires significant Agency resources to ensure achievement of contract requirements.
Fair	Overall compliance requires minor Agency resources to ensure achievement of contract requirements.
Good	There are no, or very minimal, quality problems, and the Contractor has met the contract requirements.
Excellent	There are no quality issues, and the Contractor has substantially exceeded the contract performance requirements without commensurate additional costs to the Government.
Outstanding	The contractor has demonstrated an outstanding performance level that was significantly in excess of anticipated achievements and is commendable as an example for others, so that it justifies adding a point to the score. It is expected that this rating will be used in those rare circumstances where contractor performance clearly exceeds the performance levels described as "Excellent".

### Timeliness of Performance

**0 = Unsatisfactory 1 = Poor 2 = Fair 3 = Good 4 = Excellent 5 = Outstanding**

Unsatisfactory	Delays are jeopardizing the achievement of contract requirements, despite use of Agency resources. Recovery is not likely. If performance cannot be substantially corrected, it constitutes a significant impediment in consideration for future awards.
Poor	Delays require significant Agency resources to ensure achievement of contract requirements.
Fair	Delays require minor Agency resources to ensure achievement of contract requirements.
Good	There are no, or minimal, delays that impact achievement of contract requirements.
Excellent	There are no delays and the contractor has exceeded the agreed upon time schedule.
Outstanding	The contractor has demonstrated an outstanding performance level that justifies adding a point to the score. It is expected that this rating will be used in those rare circumstances where contractor performance clearly exceeds the performance levels described as "Excellent".

### Business Relations

**0 = Unsatisfactory 1 = Poor 2 = Fair 3 = Good 4 = Excellent 5 = Outstanding**

Unsatisfactory	Response to inquiries and/or technical, service, administrative issues is not effective. If not substantially mitigated or corrected it should constitute a significant impediment in considerations for future awards.
Poor	Response to inquiries and/or technical, service, administrative issues is marginally effective.
Fair	Response to inquiries and/or technical, service, administrative issues is somewhat effective.
Good	Response to inquiries and/or technical, service, administrative issues is consistently effective.
Excellent	Response to inquiries and/or technical, service, administrative issues exceeds Government expectation.
Outstanding	The contractor has demonstrated an outstanding performance level that justifies adding a point to the score. It is expected that this rating will be used in those rare circumstances where contractor performance clearly exceeds the performance levels described as "Excellent".



By signing the filled-out form, you:

1. Certify that the TIN you are giving is correct (or you are waiting for a number to be issued),
2. Certify that you are not subject to backup withholding, or
3. Claim exemption from backup withholding if you are a U.S. exempt payee. If applicable, you are also certifying that as a U.S. person, your allocable share of any partnership income from a U.S. trade or business is not subject to the withholding tax on foreign partners' share of effectively connected income, and
4. Certify that FATCA code(s) entered on this form (if any) indicating that you are exempt from the FATCA reporting, is correct. See *What is FATCA reporting*, later, for further information.

**Note:** If you are a U.S. person and a requester gives you a form other than Form W-9 to request your TIN, you must use the requester's form if it is substantially similar to this Form W-9.

**Definition of a U.S. person.** For federal tax purposes, you are considered a U.S. person if you are:

- An individual who is a U.S. citizen or U.S. resident alien;
- A partnership, corporation, company, or association created or organized in the United States or under the laws of the United States;
- An estate (other than a foreign estate); or
- A domestic trust (as defined in Regulations section 301.7701-7).

**Special rules for partnerships.** Partnerships that conduct a trade or business in the United States are generally required to pay a withholding tax under section 1446 on any foreign partners' share of effectively connected taxable income from such business. Further, in certain cases where a Form W-9 has not been received, the rules under section 1446 require a partnership to presume that a partner is a foreign person, and pay the section 1446 withholding tax. Therefore, if you are a U.S. person that is a partner in a partnership conducting a trade or business in the United States, provide Form W-9 to the partnership to establish your U.S. status and avoid section 1446 withholding on your share of partnership income.

In the cases below, the following person must give Form W-9 to the partnership for purposes of establishing its U.S. status and avoiding withholding on its allocable share of net income from the partnership conducting a trade or business in the United States.

- In the case of a disregarded entity with a U.S. owner, the U.S. owner of the disregarded entity and not the entity;
- In the case of a grantor trust with a U.S. grantor or other U.S. owner, generally, the U.S. grantor or other U.S. owner of the grantor trust and not the trust; and
- In the case of a U.S. trust (other than a grantor trust), the U.S. trust (other than a grantor trust) and not the beneficiaries of the trust.

**Foreign person.** If you are a foreign person or the U.S. branch of a foreign bank that has elected to be treated as a U.S. person, do not use Form W-9. Instead, use the appropriate Form W-8 or Form 8233 (see Pub. 515, *Withholding of Tax on Nonresident Aliens and Foreign Entities*).

**Nonresident alien who becomes a resident alien.** Generally, only a nonresident alien individual may use the terms of a tax treaty to reduce or eliminate U.S. tax on certain types of income. However, most tax treaties contain a provision known as a "saving clause." Exceptions specified in the saving clause may permit an exemption from tax to continue for certain types of income even after the payee has otherwise become a U.S. resident alien for tax purposes.

If you are a U.S. resident alien who is relying on an exception contained in the saving clause of a tax treaty to claim an exemption from U.S. tax on certain types of income, you must attach a statement to Form W-9 that specifies the following five items.

1. The treaty country. Generally, this must be the same treaty under which you claimed exemption from tax as a nonresident alien.
2. The treaty article addressing the income.
3. The article number (or location) in the tax treaty that contains the saving clause and its exceptions.
4. The type and amount of income that qualifies for the exemption from tax.
5. Sufficient facts to justify the exemption from tax under the terms of the treaty article.

**Example.** Article 20 of the U.S.-China income tax treaty allows an exemption from tax for scholarship income received by a Chinese student temporarily present in the United States. Under U.S. law, this student will become a resident alien for tax purposes if his or her stay in the United States exceeds 5 calendar years. However, paragraph 2 of the first Protocol to the U.S.-China treaty (dated April 30, 1984) allows the provisions of Article 20 to continue to apply even after the Chinese student becomes a resident alien of the United States. A Chinese student who qualifies for this exception (under paragraph 2 of the first protocol) and is relying on this exception to claim an exemption from tax on his or her scholarship or fellowship income would attach to Form W-9 a statement that includes the information described above to support that exemption.

If you are a nonresident alien or a foreign entity, give the requester the appropriate completed Form W-8 or Form 8233.

## Backup Withholding

**What is backup withholding?** Persons making certain payments to you must under certain conditions withhold and pay to the IRS 28% of such payments. This is called "backup withholding." Payments that may be subject to backup withholding include interest, tax-exempt interest, dividends, broker and barter exchange transactions, rents, royalties, nonemployee pay, payments made in settlement of payment card and third party network transactions, and certain payments from fishing boat operators. Real estate transactions are not subject to backup withholding.

You will not be subject to backup withholding on payments you receive if you give the requester your correct TIN, make the proper certifications, and report all your taxable interest and dividends on your tax return.

**Payments you receive will be subject to backup withholding if:**

1. You do not furnish your TIN to the requester,
2. You do not certify your TIN when required (see the instructions for Part II for details),
3. The IRS tells the requester that you furnished an incorrect TIN,
4. The IRS tells you that you are subject to backup withholding because you did not report all your interest and dividends on your tax return (for reportable interest and dividends only), or
5. You do not certify to the requester that you are not subject to backup withholding under 4 above (for reportable interest and dividend accounts opened after 1983 only).

Certain payees and payments are exempt from backup withholding. See *Exempt payee code*, later, and the separate Instructions for the Requester of Form W-9 for more information.

Also see *Special rules for partnerships*, earlier.

## What is FATCA Reporting?

The Foreign Account Tax Compliance Act (FATCA) requires a participating foreign financial institution to report all United States account holders that are specified United States persons. Certain payees are exempt from FATCA reporting. See *Exemption from FATCA reporting code*, later, and the Instructions for the Requester of Form W-9 for more information.

## Updating Your Information

You must provide updated information to any person to whom you claimed to be an exempt payee if you are no longer an exempt payee and anticipate receiving reportable payments in the future from this person. For example, you may need to provide updated information if you are a C corporation that elects to be an S corporation, or if you no longer are tax exempt. In addition, you must furnish a new Form W-9 if the name or TIN changes for the account; for example, if the grantor of a grantor trust dies.

## Penalties

**Failure to furnish TIN.** If you fail to furnish your correct TIN to a requester, you are subject to a penalty of \$50 for each such failure unless your failure is due to reasonable cause and not to willful neglect.

**Civil penalty for false information with respect to withholding.** If you make a false statement with no reasonable basis that results in no backup withholding, you are subject to a \$500 penalty.

**Criminal penalty for falsifying information.** Willfully falsifying certifications or affirmations may subject you to criminal penalties including fines and/or imprisonment.

**Misuse of TINs.** If the requester discloses or uses TINs in violation of federal law, the requester may be subject to civil and criminal penalties.

## Specific Instructions

### Line 1

You must enter one of the following on this line; **do not** leave this line blank. The name should match the name on your tax return.

If this Form W-9 is for a joint account (other than an account maintained by a foreign financial institution (FFI)), list first, and then circle, the name of the person or entity whose number you entered in Part I of Form W-9. If you are providing Form W-9 to an FFI to document a joint account, each holder of the account that is a U.S. person must provide a Form W-9.

a. **Individual.** Generally, enter the name shown on your tax return. If you have changed your last name without informing the Social Security Administration (SSA) of the name change, enter your first name, the last name as shown on your social security card, and your new last name.

**Note: ITIN applicant:** Enter your individual name as it was entered on your Form W-7 application, line 1a. This should also be the same as the name you entered on the Form 1040/1040A/1040EZ you filed with your application.

b. **Sole proprietor or single-member LLC.** Enter your individual name as shown on your 1040/1040A/1040EZ on line 1. You may enter your business, trade, or “doing business as” (DBA) name on line 2.

c. **Partnership, LLC that is not a single-member LLC, C corporation, or S corporation.** Enter the entity’s name as shown on the entity’s tax return on line 1 and any business, trade, or DBA name on line 2.

d. **Other entities.** Enter your name as shown on required U.S. federal tax documents on line 1. This name should match the name shown on the charter or other legal document creating the entity. You may enter any business, trade, or DBA name on line 2.

e. **Disregarded entity.** For U.S. federal tax purposes, an entity that is disregarded as an entity separate from its owner is treated as a “disregarded entity.” See Regulations section 301.7701-2(c)(2)(iii). Enter the owner’s name on line 1. The name of the entity entered on line 1 should never be a disregarded entity. The name on line 1 should be the name shown on the income tax return on which the income should be reported. For example, if a foreign LLC that is treated as a disregarded entity for U.S. federal tax purposes has a single owner that is a U.S. person, the U.S. owner’s name is required to be provided on line 1. If the direct owner of the entity is also a disregarded entity, enter the first owner that is not disregarded for federal tax purposes. Enter the disregarded entity’s name on line 2, “Business name/disregarded entity name.” If the owner of the disregarded entity is a foreign person, the owner must complete an appropriate Form W-8 instead of a Form W-9. This is the case even if the foreign person has a U.S. TIN.

### Line 2

If you have a business name, trade name, DBA name, or disregarded entity name, you may enter it on line 2.

### Line 3

Check the appropriate box on line 3 for the U.S. federal tax classification of the person whose name is entered on line 1. Check only one box on line 3.

IF the entity/person on line 1 is a(n) . . .	THEN check the box for . . .
• Corporation	Corporation
• Individual • Sole proprietorship, or • Single-member limited liability company (LLC) owned by an individual and disregarded for U.S. federal tax purposes.	Individual/sole proprietor or single-member LLC
• LLC treated as a partnership for U.S. federal tax purposes, • LLC that has filed Form 8832 or 2553 to be taxed as a corporation, or • LLC that is disregarded as an entity separate from its owner but the owner is another LLC that is not disregarded for U.S. federal tax purposes.	Limited liability company and enter the appropriate tax classification. (P= Partnership; C= C corporation; or S= S corporation)
• Partnership	Partnership
• Trust/estate	Trust/estate

### Line 4, Exemptions

If you are exempt from backup withholding and/or FATCA reporting, enter in the appropriate space on line 4 any code(s) that may apply to you.

#### Exempt payee code.

- Generally, individuals (including sole proprietors) are not exempt from backup withholding.
- Except as provided below, corporations are exempt from backup withholding for certain payments, including interest and dividends.
- Corporations are not exempt from backup withholding for payments made in settlement of payment card or third party network transactions.
- Corporations are not exempt from backup withholding with respect to attorneys’ fees or gross proceeds paid to attorneys, and corporations that provide medical or health care services are not exempt with respect to payments reportable on Form 1099-MISC.

The following codes identify payees that are exempt from backup withholding. Enter the appropriate code in the space in line 4.

- 1—An organization exempt from tax under section 501(a), any IRA, or a custodial account under section 403(b)(7) if the account satisfies the requirements of section 401(f)(2)
- 2—The United States or any of its agencies or instrumentalities
- 3—A state, the District of Columbia, a U.S. commonwealth or possession, or any of their political subdivisions or instrumentalities
- 4—A foreign government or any of its political subdivisions, agencies, or instrumentalities
- 5—A corporation
- 6—A dealer in securities or commodities required to register in the United States, the District of Columbia, or a U.S. commonwealth or possession
- 7—A futures commission merchant registered with the Commodity Futures Trading Commission
- 8—A real estate investment trust
- 9—An entity registered at all times during the tax year under the Investment Company Act of 1940
- 10—A common trust fund operated by a bank under section 584(a)
- 11—A financial institution
- 12—A middleman known in the investment community as a nominee or custodian
- 13—A trust exempt from tax under section 664 or described in section 4947

The following chart shows types of payments that may be exempt from backup withholding. The chart applies to the exempt payees listed above, 1 through 13.

IF the payment is for . . .	THEN the payment is exempt for . . .
Interest and dividend payments	All exempt payees except for 7
Broker transactions	Exempt payees 1 through 4 and 6 through 11 and all C corporations. S corporations must not enter an exempt payee code because they are exempt only for sales of noncovered securities acquired prior to 2012.
Barter exchange transactions and patronage dividends	Exempt payees 1 through 4
Payments over \$600 required to be reported and direct sales over \$5,000 <sup>1</sup>	Generally, exempt payees 1 through 5 <sup>2</sup>
Payments made in settlement of payment card or third party network transactions	Exempt payees 1 through 4

<sup>1</sup> See Form 1099-MISC, Miscellaneous Income, and its instructions.

<sup>2</sup> However, the following payments made to a corporation and reportable on Form 1099-MISC are not exempt from backup withholding: medical and health care payments, attorneys' fees, gross proceeds paid to an attorney reportable under section 6045(f), and payments for services paid by a federal executive agency.

**Exemption from FATCA reporting code.** The following codes identify payees that are exempt from reporting under FATCA. These codes apply to persons submitting this form for accounts maintained outside of the United States by certain foreign financial institutions. Therefore, if you are only submitting this form for an account you hold in the United States, you may leave this field blank. Consult with the person requesting this form if you are uncertain if the financial institution is subject to these requirements. A requester may indicate that a code is not required by providing you with a Form W-9 with "Not Applicable" (or any similar indication) written or printed on the line for a FATCA exemption code.

A—An organization exempt from tax under section 501(a) or any individual retirement plan as defined in section 7701(a)(37)

B—The United States or any of its agencies or instrumentalities

C—A state, the District of Columbia, a U.S. commonwealth or possession, or any of their political subdivisions or instrumentalities

D—A corporation the stock of which is regularly traded on one or more established securities markets, as described in Regulations section 1.1472-1(c)(1)(i)

E—A corporation that is a member of the same expanded affiliated group as a corporation described in Regulations section 1.1472-1(c)(1)(i)

F—A dealer in securities, commodities, or derivative financial instruments (including notional principal contracts, futures, forwards, and options) that is registered as such under the laws of the United States or any state

G—A real estate investment trust

H—A regulated investment company as defined in section 851 or an entity registered at all times during the tax year under the Investment Company Act of 1940

I—A common trust fund as defined in section 584(a)

J—A bank as defined in section 581

K—A broker

L—A trust exempt from tax under section 664 or described in section 4947(a)(1)

M—A tax exempt trust under a section 403(b) plan or section 457(g) plan

**Note:** You may wish to consult with the financial institution requesting this form to determine whether the FATCA code and/or exempt payee code should be completed.

## Line 5

Enter your address (number, street, and apartment or suite number). This is where the requester of this Form W-9 will mail your information returns. If this address differs from the one the requester already has on file, write NEW at the top. If a new address is provided, there is still a chance the old address will be used until the payor changes your address in their records.

## Line 6

Enter your city, state, and ZIP code.

## Part I. Taxpayer Identification Number (TIN)

**Enter your TIN in the appropriate box.** If you are a resident alien and you do not have and are not eligible to get an SSN, your TIN is your IRS individual taxpayer identification number (ITIN). Enter it in the social security number box. If you do not have an ITIN, see *How to get a TIN* below.

If you are a sole proprietor and you have an EIN, you may enter either your SSN or EIN.

If you are a single-member LLC that is disregarded as an entity separate from its owner, enter the owner's SSN (or EIN, if the owner has one). Do not enter the disregarded entity's EIN. If the LLC is classified as a corporation or partnership, enter the entity's EIN.

**Note:** See *What Name and Number To Give the Requester*, later, for further clarification of name and TIN combinations.

**How to get a TIN.** If you do not have a TIN, apply for one immediately. To apply for an SSN, get Form SS-5, Application for a Social Security Card, from your local SSA office or get this form online at [www.SSA.gov](http://www.SSA.gov). You may also get this form by calling 1-800-772-1213. Use Form W-7, Application for IRS Individual Taxpayer Identification Number, to apply for an ITIN, or Form SS-4, Application for Employer Identification Number, to apply for an EIN. You can apply for an EIN online by accessing the IRS website at [www.irs.gov/Businesses](http://www.irs.gov/Businesses) and clicking on Employer Identification Number (EIN) under Starting a Business. Go to [www.irs.gov/Forms](http://www.irs.gov/Forms) to view, download, or print Form W-7 and/or Form SS-4. Or, you can go to [www.irs.gov/OrderForms](http://www.irs.gov/OrderForms) to place an order and have Form W-7 and/or SS-4 mailed to you within 10 business days.

If you are asked to complete Form W-9 but do not have a TIN, apply for a TIN and write "Applied For" in the space for the TIN, sign and date the form, and give it to the requester. For interest and dividend payments, and certain payments made with respect to readily tradable instruments, generally you will have 60 days to get a TIN and give it to the requester before you are subject to backup withholding on payments. The 60-day rule does not apply to other types of payments. You will be subject to backup withholding on all such payments until you provide your TIN to the requester.

**Note:** Entering "Applied For" means that you have already applied for a TIN or that you intend to apply for one soon.

**Caution:** A disregarded U.S. entity that has a foreign owner must use the appropriate Form W-8.

## Part II. Certification

To establish to the withholding agent that you are a U.S. person, or resident alien, sign Form W-9. You may be requested to sign by the withholding agent even if item 1, 4, or 5 below indicates otherwise.

For a joint account, only the person whose TIN is shown in Part I should sign (when required). In the case of a disregarded entity, the person identified on line 1 must sign. Exempt payees, see *Exempt payee code*, earlier.

**Signature requirements.** Complete the certification as indicated in items 1 through 5 below.

**1. Interest, dividend, and barter exchange accounts opened before 1984 and broker accounts considered active during 1983.**

You must give your correct TIN, but you do not have to sign the certification.

**2. Interest, dividend, broker, and barter exchange accounts opened after 1983 and broker accounts considered inactive during 1983.**

You must sign the certification or backup withholding will apply. If you are subject to backup withholding and you are merely providing your correct TIN to the requester, you must cross out item 2 in the certification before signing the form.

**3. Real estate transactions.**

You must sign the certification. You may cross out item 2 of the certification.

**4. Other payments.** You must give your correct TIN, but you do not have to sign the certification unless you have been notified that you have previously given an incorrect TIN. "Other payments" include payments made in the course of the requester's trade or business for rents, royalties, goods (other than bills for merchandise), medical and health care services (including payments to corporations), payments to a nonemployee for services, payments made in settlement of payment card and third party network transactions, payments to certain fishing boat crew members and fishermen, and gross proceeds paid to attorneys (including payments to corporations).

**5. Mortgage interest paid by you, acquisition or abandonment of secured property, cancellation of debt, qualified tuition program payments (under section 529), ABLE accounts (under section 529A), IRA, Coverdell ESA, Archer MSA or HSA contributions or distributions, and pension distributions.** You must give your correct TIN, but you do not have to sign the certification.

**What Name and Number To Give the Requester**

For this type of account:	Give name and SSN of:
1. Individual	The individual
2. Two or more individuals (joint account) other than an account maintained by an FFI	The actual owner of the account or, if combined funds, the first individual on the account <sup>1</sup>
3. Two or more U.S. persons (joint account maintained by an FFI)	Each holder of the account
4. Custodial account of a minor (Uniform Gift to Minors Act)	The minor <sup>2</sup>
5. a. The usual revocable savings trust (grantor is also trustee)	The grantor-trustee <sup>1</sup>
b. So-called trust account that is not a legal or valid trust under state law	The actual owner <sup>1</sup>
6. Sole proprietorship or disregarded entity owned by an individual	The owner <sup>3</sup>
7. Grantor trust filing under Optional Form 1099 Filing Method 1 (see Regulations section 1.671-4(b)(2)(i)(A))	The grantor*
For this type of account:	Give name and EIN of:
8. Disregarded entity not owned by an individual	The owner
9. A valid trust, estate, or pension trust	Legal entity <sup>4</sup>
10. Corporation or LLC electing corporate status on Form 8832 or Form 2553	The corporation
11. Association, club, religious, charitable, educational, or other tax-exempt organization	The organization
12. Partnership or multi-member LLC	The partnership
13. A broker or registered nominee	The broker or nominee

For this type of account:	Give name and EIN of:
14. Account with the Department of Agriculture in the name of a public entity (such as a state or local government, school district, or prison) that receives agricultural program payments	The public entity
15. Grantor trust filing under the Form 1041 Filing Method or the Optional Form 1099 Filing Method 2 (see Regulations section 1.671-4(b)(2)(i)(B))	The trust

<sup>1</sup> List first and circle the name of the person whose number you furnish. If only one person on a joint account has an SSN, that person's number must be furnished.

<sup>2</sup> Circle the minor's name and furnish the minor's SSN.

<sup>3</sup> You must show your individual name and you may also enter your business or DBA name on the "Business name/disregarded entity" name line. You may use either your SSN or EIN (if you have one), but the IRS encourages you to use your SSN.

<sup>4</sup> List first and circle the name of the trust, estate, or pension trust. (Do not furnish the TIN of the personal representative or trustee unless the legal entity itself is not designated in the account title.) Also see *Special rules for partnerships*, earlier.

\*Note: The grantor also must provide a Form W-9 to trustee of trust.

Note: If no name is circled when more than one name is listed, the number will be considered to be that of the first name listed.

**Secure Your Tax Records From Identity Theft**

Identity theft occurs when someone uses your personal information such as your name, SSN, or other identifying information, without your permission, to commit fraud or other crimes. An identity thief may use your SSN to get a job or may file a tax return using your SSN to receive a refund.

To reduce your risk:

- Protect your SSN,
- Ensure your employer is protecting your SSN, and
- Be careful when choosing a tax preparer.

If your tax records are affected by identity theft and you receive a notice from the IRS, respond right away to the name and phone number printed on the IRS notice or letter.

If your tax records are not currently affected by identity theft but you think you are at risk due to a lost or stolen purse or wallet, questionable credit card activity or credit report, contact the IRS Identity Theft Hotline at 1-800-908-4490 or submit Form 14039.

For more information, see Pub. 5027, Identity Theft Information for Taxpayers.

Victims of identity theft who are experiencing economic harm or a systemic problem, or are seeking help in resolving tax problems that have not been resolved through normal channels, may be eligible for Taxpayer Advocate Service (TAS) assistance. You can reach TAS by calling the TAS toll-free case intake line at 1-877-777-4778 or TTY/TDD 1-800-829-4059.

**Protect yourself from suspicious emails or phishing schemes.**

Phishing is the creation and use of email and websites designed to mimic legitimate business emails and websites. The most common act is sending an email to a user falsely claiming to be an established legitimate enterprise in an attempt to scam the user into surrendering private information that will be used for identity theft.

The IRS does not initiate contacts with taxpayers via emails. Also, the IRS does not request personal detailed information through email or ask taxpayers for the PIN numbers, passwords, or similar secret access information for their credit card, bank, or other financial accounts.

If you receive an unsolicited email claiming to be from the IRS, forward this message to [phishing@irs.gov](mailto:phishing@irs.gov). You may also report misuse of the IRS name, logo, or other IRS property to the Treasury Inspector General for Tax Administration (TIGTA) at 1-800-366-4484. You can forward suspicious emails to the Federal Trade Commission at [spam@uce.gov](mailto:spam@uce.gov) or report them at [www.ftc.gov/complaint](http://www.ftc.gov/complaint). You can contact the FTC at [www.ftc.gov/idtheft](http://www.ftc.gov/idtheft) or 877-IDTHEFT (877-438-4338). If you have been the victim of identity theft, see [www.IdentityTheft.gov](http://www.IdentityTheft.gov) and Pub. 5027.

Visit [www.irs.gov/IdentityTheft](http://www.irs.gov/IdentityTheft) to learn more about identity theft and how to reduce your risk.

## Privacy Act Notice

Section 6109 of the Internal Revenue Code requires you to provide your correct TIN to persons (including federal agencies) who are required to file information returns with the IRS to report interest, dividends, or certain other income paid to you; mortgage interest you paid; the acquisition or abandonment of secured property; the cancellation of debt; or contributions you made to an IRA, Archer MSA, or HSA. The person collecting this form uses the information on the form to file information returns with the IRS, reporting the above information. Routine uses of this information include giving it to the Department of Justice for civil and criminal litigation and to cities, states, the District of Columbia, and U.S. commonwealths and possessions for use in administering their laws. The information also may be disclosed to other countries under a treaty, to federal and state agencies to enforce civil and criminal laws, or to federal law enforcement and intelligence agencies to combat terrorism. You must provide your TIN whether or not you are required to file a tax return. Under section 3406, payers must generally withhold a percentage of taxable interest, dividend, and certain other payments to a payee who does not give a TIN to the payer. Certain penalties may also apply for providing false or fraudulent information.

REGISTER OF WAGE DETERMINATIONS UNDER  
THE SERVICE CONTRACT ACT  
By direction of the Secretary of Labor

U.S. DEPARTMENT OF LABOR  
EMPLOYMENT STANDARDS ADMINISTRATION  
WAGE AND HOUR DIVISION  
WASHINGTON D.C. 20210

Daniel W. Simms  
Director

Division of  
Wage Determinations

Wage Determination No.: 1995-0221  
Revision No.: 42  
Date Of Last Revision: 12/26/2017

Note: Under Executive Order (EO) 13658, an hourly minimum wage of \$10.35 for calendar year 2018 applies to all contracts subject to the Service Contract Act for which the contract is awarded (and any solicitation was issued) on or after January 1, 2015. If this contract is covered by the EO, the contractor must pay all workers in any classification listed on this wage determination at least \$10.35 per hour (or the applicable wage rate listed on this wage determination, if it is higher) for all hours spent performing on the contract in calendar year 2018. The EO minimum wage rate will be adjusted annually.

Additional information on contractor requirements and worker protections under the EO is available at [www.dol.gov/whd/govcontracts](http://www.dol.gov/whd/govcontracts)

NATIONWIDE: Applicable in the continental U.S., Hawaii, Alaska, and American Samoa.

Alaska: Entire state.

American Samoa: Entire state

Hawaii: Entire state.

Midwestern Region: Illinois, Indiana, Iowa, Kansas, Michigan, Minnesota, Missouri, Nebraska, North Dakota, Ohio, South Dakota, Wisconsin

Northeast Region: Connecticut, Maine, Massachusetts, New Hampshire, New Jersey, New York, Pennsylvania, Rhode Island, Vermont

Southern Region: Alabama, Arkansas, Delaware, District of Columbia, Florida, Georgia, Kentucky, Louisiana, Maryland, Mississippi, North Carolina, Oklahoma, South Carolina, Tennessee, Texas, Virginia, West Virginia

Western Region: Arizona, California, Colorado, Idaho, Montana, Nevada, New Mexico, Oregon, Utah, Washington, Wyoming

**\*\*Fringe Benefits Required Follow the Occupational Listing\*\***

Employed on contracts for Fire Safety services only.

OCCUPATION CODE - TITLE	FOOTNOTE	RATE
01000 - Administrative Support And Clerical Occupations		
01613 - Word Processor III		
Alaska		19.30
Continental U.S.		19.30
Hawaii and American Samoa		19.06
05000 - Automotive Service Occupations		

05190 - Motor Vehicle Mechanic	
Alaska	27.24
Hawaii and American Samoa	18.09
Midwestern Region	21.49
Northeast Region	20.18
Southern Region	18.80
Western Region	21.75
05220 - Motor Vehicle Mechanic Helper	
Alaska	19.70
Hawaii and American Samoa	13.93
Midwestern Region	13.94
Northeast Region	15.72
Southern Region	12.12
Western Region	14.74
07000 - Food Preparation And Service Occupations	
07010 - Baker	
Alaska	16.36
Hawaii and American Samoa	16.34
Midwestern Region	13.71
Northeast Region	15.56
Southern Region	11.20
Western Region	17.08
07041 - Cook I	
Alaska	14.10
Hawaii and American Samoa	13.75
Midwestern Region	10.08
Northeast Region	12.58
Southern Region	9.59
Western Region	11.49
07042 - Cook II	
Alaska	16.25
Hawaii and American Samoa	15.36
Midwestern Region	11.36
Northeast Region	14.18
Southern Region	10.82
Western Region	12.95
07070 - Dishwasher	
Alaska	12.07
Hawaii and American Samoa	13.23
Midwestern Region	8.16
Northeast Region	8.74
Southern Region	8.48
Western Region	8.80
07130 - Food Service Worker	
Alaska	12.31
Hawaii and American Samoa	12.25
Midwestern Region	9.63
Northeast Region	11.54
Southern Region	9.11
Western Region	10.01
07210 - Meat Cutter	
Alaska	20.08
Hawaii and American Samoa	19.49

Midwestern Region	16.92
Northeast Region	19.70
Southern Region	14.12
Western Region	18.48
12000 - Health Occupations	
12040 - Emergency Medical Technician	
Alaska	23.55
Continental U.S.	17.15
Hawaii and American Samoa	19.29
21000 - Materials Handling And Packing Occupations	
21020 - Forklift Operator	
Alaska	22.62
Hawaii and American Samoa	17.62
Midwestern Region	16.26
Northeast Region	15.88
Southern Region	13.45
Western Region	17.39
21150 - Stock Clerk	
Alaska	14.61
Hawaii and American Samoa	11.52
Midwestern Region	12.91
Northeast Region	12.74
Southern Region	12.37
Western Region	13.08
23000 - Mechanics And Maintenance And Repair Occupations	
23021 - Aircraft Mechanic I	
Alaska	28.68
Continental U.S.	29.50
Hawaii and American Samoa	29.64
23022 - Aircraft Mechanic II	
Alaska	29.78
Continental U.S.	30.26
Hawaii and American Samoa	30.86
23023 - Aircraft Mechanic III	
Alaska	31.41
Continental U.S.	31.63
Hawaii and American Samoa	32.39
23040 - Aircraft Mechanic Helper	
Alaska	22.49
Continental U.S.	22.18
Hawaii and American Samoa	21.40
23060 - Aircraft Servicer	
Alaska	25.13
Continental U.S.	25.31
Hawaii and American Samoa	24.84
23160 - Electrician, Maintenance	
Alaska	32.38
Hawaii and American Samoa	27.90
Midwestern Region	24.31
Northeast Region	26.05
Southern Region	20.78
Western Region	24.82
23440 - Heavy Equipment Operator	

Alaska	26.48
Hawaii and American Samoa	18.84
Midwestern Region	21.49
Northeast Region	20.18
Southern Region	18.80
Western Region	21.74
23470 - Laborer	
Alaska	16.07
Hawaii and American Samoa	15.60
Midwestern Region	13.08
Northeast Region	13.19
Southern Region	10.64
Western Region	12.35
23530 - Machinery Maintenance Mechanic	
Alaska	30.21
Hawaii and American Samoa	29.81
Midwestern Region	18.64
Northeast Region	19.49
Southern Region	14.77
Western Region	18.49
23580 - Maintenance Trades Helper	
Alaska	22.09
Hawaii and American Samoa	17.04
Midwestern Region	17.54
Northeast Region	16.38
Southern Region	14.76
Western Region	15.22
27000 - Protective Service Occupations	
27070 - Firefighter	
Alaska	12.24
Hawaii and American Samoa	9.97
Midwestern Region	7.98
Northeast Region	8.41
Southern Region	7.98
Western Region	8.41
30000 - Technical Occupations	
30210 - Laboratory Technician	
Alaska	23.69
Hawaii and American Samoa	22.53
Mid Western Region	21.05
Northeast Region	19.48
Southern Region	21.41
Western Region	20.02
31000 - Transportation/Mobile Equipment Operation Occupations	
31030 - Bus Driver	
Alaska	22.22
Hawaii and American Samoa	14.43
Midwestern Region: 1 1/2 to 4 tons	18.31
Midwestern Region: over 4 tons	19.15
Midwestern Region: under 1 1/2 tons	13.70
Northeast Region: 1 1/2 to 4 tons	18.77
Northeast Region: over 4 tons	19.59
Northeast Region: under 1 1/2 tons	14.56

Southern Region: 1 1/2 to 4 tons	16.72
Southern Region: over 4 tons	17.35
Southern Region: under 1 1/2 tons	9.32
Western Region: 1 1/2 to 4 tons	17.24
Western Region: over 4 tons	17.73
Western Region: under 1 1/2 tons	10.85
31361 - Truckdriver, Light	
Alaska	20.80
Hawaii and American Samoa	11.38
Midwestern Region	13.70
Northeast Region	14.56
Southern Region	9.32
Western Region	10.85
31362 - Truckdriver, Medium	
Alaska	22.52
Hawaii and American Samoa	14.42
Midwestern Region	18.31
Northeast Region	18.77
Southern Region	16.67
Western Region	17.24
31363 - Truckdriver, Heavy	
Alaska	23.80
Hawaii and American Samoa	15.74
Midwestern Region	19.15
Northeast Region	19.59
Southern Region	17.35
Western Region	18.37
31364 - Truckdriver, Tractor-Trailer	
Alaska	25.07
Hawaii and American Samoa	15.94
Midwestern Region	22.76
Northeast Region	19.72
Southern Region	18.23
Western Region	18.75
47000 - Water Transportation Occupations	
47021 - Cook-Baker/Second Cook/Second Cook- Baker/Assistant Cook	
Alaska	16.18
Hawaii and American Samoa	15.36
Midwestern Region	11.36
Northeast Region	14.18
Southern Region	10.81
Western Region	12.95
92000 - Non Standard Occupations	
(not set) - Quality Assurance Representative I	
Alaska	20.11
Hawaii and American Samoa	20.66
Midwestern Region	18.10
Northeast Region	19.12
Southern Region	19.82
Western Region	18.24
(not set) - Quality Assurance Representative II	
Alaska	26.31

Hawaii and American Samoa	24.56
Midwestern Region	22.33
Northeast Region	23.73
Southern Region	20.97
Western Region	22.11
(not set) - Quality Assurance Representative III	
Alaska	27.99
Hawaii and American Samoa	26.73
Midwestern Region	26.29
Northeast Region	27.93
Southern Region	24.80
Western Region	26.51
(not set) - Chief Cook	
Alaska	21.49
Hawaii and American Samoa	25.76
Midwestern Region	18.95
Northeast Region	22.94
Southern Region	17.37
Western Region	21.10
(not set) - Environmental Protection Specialist	
Alaska	33.90
Hawaii and American Samoa	31.35
Midwestern Region	28.52
Northeast Region	34.20
Southern Region	29.04
Western Region	30.03
(not set) - Fire Safety Professional	
Alaska	33.88
Hawaii and American Samoa	31.39
Midwestern Region	28.52
Northeast Region	34.20
Southern Region	29.04
Western Region	30.03
(not set) - Aircraft Quality Control Inspector	
Alaska	30.00
Continental U.S.	30.84
Hawaii and American Samoa	31.01
99000 - Miscellaneous Occupations	
99730 - Refuse Collector	
Alaska	11.88
Hawaii and American Samoa	10.98
Midwestern Region	10.15
Northeast Region	11.59
Southern Region	7.98
Western Region	9.88

---

Note: Executive Order (EO) 13706, Establishing Paid Sick Leave for Federal Contractors, applies to all contracts subject to the Service Contract Act for which the contract is awarded (and any solicitation was issued) on or after January 1, 2017. If this contract is covered by the EO, the contractor must provide employees with 1 hour of paid sick leave for every 30 hours they work, up to 56 hours of paid sick leave each year. Employees must be permitted to use paid sick leave for their own illness, injury or other health-related needs, including preventive care; to assist a family member (or person who is like family to the employee) who is ill, injured, or has other health-related needs, including preventive care; or for

reasons resulting from, or to assist a family member (or person who is like family to the employee) who is the victim of, domestic violence, sexual assault, or stalking. Additional information on contractor requirements and worker protections under the EO is available at [www.dol.gov/whd/govcontracts](http://www.dol.gov/whd/govcontracts).

ALL OCCUPATIONS LISTED ABOVE RECEIVE THE FOLLOWING BENEFITS:

HEALTH & WELFARE: \$4.41 per hour or \$176.40 per week or \$764.40 per month

HEALTH & WELFARE EO 13706: \$4.13 per hour, or \$165.20 per week, or \$715.87 per month

VACATION: 2 weeks paid vacation after 1 year of service with a contractor or successor, 3 weeks after 10 years, and 4 weeks after 15 years. Length of service includes the whole span of continuous service with the present contractor or successor, wherever employed, and with the predecessor contractors in the performance of similar work at the same Federal facility. (See 29 CFR 4.173)

HOLIDAYS: A minimum of ten paid holidays per year: New Year's Day, Martin Luther King Jr.'s Birthday, Washington's Birthday, Memorial Day, Independence Day, Labor Day, Columbus Day, Veterans' Day, Thanksgiving Day, and Christmas Day. (A contractor may substitute for any of the named holidays another day off with pay in accordance with a plan communicated to the employees involved.) (See 29 CFR 4.174)

VACATION (Hawaii): 2 weeks paid vacation after 1 year of service with a contractor or successor; 3 weeks after 10 years, and 4 weeks after 15 years. Length of service includes the whole span of continuous service with the present contractor or successor, wherever employed, and with the predecessor contractors in the performance of similar work at the same Federal facility. (Reg. 29 CFR 4.173)

HEALTH & WELFARE (Hawaii): \$1.91 per hour, or \$76.40 per week, or \$331.07 per month for all employees on whose behalf the contractor provides health care benefits pursuant to the Hawaii prepaid Health Care Act. For those employees who are not receiving health care benefits mandated by the Hawaii prepaid Health Care Act, the new health and welfare benefit rate will be \$4.41 per hour.

HEALTH & WELFARE (Hawaii EO 13706): \$1.63 per hour, or \$65.20 per week, or \$282.53 per month for all employees on whose behalf the contractor provides health care benefits pursuant to the Hawaii prepaid Health Care Act. For those employees who are not receiving health care benefits mandated by the Hawaii prepaid Health Care Act, the new health and welfare benefit rate will be \$4.13 per hour.

**\*\* HAZARDOUS PAY DIFFERENTIAL \*\***

An 8 percent differential is applicable to employees employed in a position that represents a high degree of hazard when working with or in close proximity to ordnance, explosives, and incendiary materials. This includes work such as screening, blending, dying, mixing, and pressing of sensitive ordnance, explosives, and pyrotechnic compositions such as lead azide, black powder and photoflash powder. All dry-house activities involving propellants or explosives. Demilitarization, modification, renovation, demolition, and maintenance operations on sensitive ordnance, explosives and incendiary materials. All operations involving re-grading and cleaning of artillery ranges.

A 4 percent differential is applicable to employees employed in a position that represents a low degree of hazard when working with, or in close proximity to ordnance, (or employees possibly adjacent to) explosives and incendiary materials which involves potential injury such as laceration of hands, face, or arms of the employee engaged in the operation, irritation of the skin, minor burns and the like; minimal damage to immediate or adjacent work area or equipment being used. All operations involving, unloading, storage, and hauling of ordnance, explosive, and incendiary ordnance material other than small arms ammunition. These differentials are only applicable to work that has been specifically designated by the agency for ordnance, explosives, and incendiary material differential pay.

**\*\* UNIFORM ALLOWANCE \*\***

If employees are required to wear uniforms in the performance of this contract (either by the terms of the Government contract, by the employer, by the state or local law, etc.), the cost of furnishing such uniforms and maintaining (by laundering or dry cleaning) such uniforms is an expense that may not be borne by an employee where such cost reduces the hourly rate below that required by the wage determination. The Department of Labor will accept payment in accordance with the following standards as compliance:

The contractor or subcontractor is required to furnish all employees with an adequate number of uniforms without cost or to reimburse employees for the actual cost of the uniforms. In addition, where uniform cleaning and maintenance is made the responsibility of the employee, all contractors and subcontractors subject to this wage determination shall (in the absence of a bona fide collective bargaining agreement providing for a different amount, or the furnishing of contrary affirmative proof as to the actual cost), reimburse all employees for such cleaning and maintenance at a rate of \$3.35 per week (or \$.67 cents per day). However, in those instances where the uniforms furnished are made of "wash and wear" materials, may be routinely washed and dried with other personal garments, and do not require any special treatment such as dry cleaning, daily washing, or commercial laundering in order to meet the cleanliness or appearance standards set by the terms of the Government contract, by the contractor, by law, or by the nature of the work, there is no requirement that employees be reimbursed for uniform maintenance costs.

**\*\* SERVICE CONTRACT ACT DIRECTORY OF OCCUPATIONS \*\***

The duties of employees under job titles listed are those described in the "Service Contract Act Directory of Occupations", Fifth Edition (Revision 1), dated September 2015, unless otherwise indicated.

**REQUEST FOR AUTHORIZATION OF ADDITIONAL CLASSIFICATION AND WAGE RATE**

Standard Form 1444 (SF-1444)

**Conformance Process:**

The contracting officer shall require that any class of service employee which is not listed herein and which is to be employed under the contract (i.e., the work to be performed is not performed by any classification listed in the wage determination), be classified by the contractor so as to provide a reasonable relationship (i.e., appropriate level of skill comparison) between such unlisted classifications and the classifications listed in the wage determination. Such conformed classes of employees shall be paid the monetary wages and furnished the fringe benefits as are determined (See 29 CFR 4.6(b)(2)(i)). Such conforming procedures shall be initiated by the contractor prior to the performance of contract work by such unlisted class(es) of employees (See 29 CFR 4.6(b)(2)(ii)). The Wage and Hour Division shall make a final determination of conformed classification, wage rate, and/or fringe benefits which shall be retroactive to the commencement date of the contract (See 29 CFR 4.6(b)(2)(iv)(C)(vi)). When multiple wage determinations are included in a contract, a separate SF-1444 should be prepared for each wage determination to which a class(es) is to be conformed.

The process for preparing a conformance request is as follows:

- 1) When preparing the bid, the contractor identifies the need for a conformed occupation(s) and computes a proposed rate(s).
- 2) After contract award, the contractor prepares a written report listing in order the proposed classification title(s), a Federal grade equivalency (FGE) for each proposed classification(s), job description(s), and rationale for proposed wage rate(s), including information regarding the agreement or disagreement of the authorized representative of the employees involved, or where there is no authorized representative, the employees themselves. This report should be

submitted to the contracting officer no later than 30 days after such unlisted class(es) of employees performs any contract work.

3) The contracting officer reviews the proposed action and promptly submits a report of the action, together with the agency's recommendations and pertinent information including the position of the contractor and the employees, to the Wage and Hour Division, U.S. Department of Labor, for review (See 29 CFR 4.6(b)(2)(ii)).

4) Within 30 days of receipt, the Wage and Hour Division approves, modifies, or disapproves the action via transmittal to the agency contracting officer, or notifies the contracting officer that additional time will be required to process the request.

5) The contracting officer transmits the Wage and Hour decision to the contractor.

6) The contractor informs the affected employees.

Information required by the Regulations must be submitted on SF-1444 or bond paper.

When preparing a conformance request, the "Service Contract Act Directory of Occupations" (the Directory) should be used to compare job definitions to ensure that duties requested are not performed by a classification already listed in the wage determination. Remember, it is not the job title, but the required tasks that determine whether a class is included in an established wage determination. Conformances may not be used to artificially split, combine, or subdivide classifications listed in the wage determination.

**\*\* OCCUPATIONS NOT INCLUDED IN THE SCA DIRECTORY OF OCCUPATIONS \*\***

**Aircraft Quality Control Inspector**

Develops and implements quality control and ground safety programs to ensure compliance with contract specifications. Inspects and verifies proper completion and documentation of safety and flight discrepancies. Briefs and debriefs pilots and crew members assigned to functional check flights. Evaluates personnel, including verification of skills, training and experience. Performs audits and inspections of work centers and ongoing maintenance actions, procedures, equipment and facilities. Monitors timeliness and applicability of aircraft maintenance technical data and technical library. Reviews maintenance source documents, aircraft inspection records, notes recurring discrepancies or trends and initiates appropriate action. Manages the material deficiency and technical order improvement program. Reviews engineering investigation requests. Initiates and reviews quality deficiency reports, technical deficiency reports and hazardous material reports, ensuring that they are accurate, clear, concise and comprehensive. Receives aircraft and explosive mishap reports and studies them for applicability. Oversees aircraft weight and balance program. Conducts safety inspections, training and drills.

**Chief Cook**

Directs and participates in the preparation and serving of meals; determines timing and sequence of operations required to meet serving times; inspects galley/kitchen unit and equipment for cleanliness and proper storage and preparation of food. Many plan or assist in planning meals and taking inventory of stores and equipment.

**Environmental Protection Specialist**

Environmental protection specialist positions require specialized knowledge of the principles, practices, and methods of program or administrative work relating to environmental protection programs. This entails (1) an understanding of the philosophy underlying environmental regulation; (2) knowledge of environmental laws and regulations; (3) knowledge of the planning, funding, organization, administration, and evaluation of environmental programs; (4) practical knowledge of environmental sciences and related disciplines, the effects of actions and technology on the environment, the means

of preventing or reducing pollution, and the relationship between environmental factors and human health and well-being; and (5) practical knowledge of important historic, cultural, and natural resources (including land, vegetation, fish, wildlife, endangered species, forests) and the relationship between the preservation and management of these resources and environmental protection. Environmental protection specialists apply specialized knowledge of one or more program or functional areas of environmental protection work, but do not require full professional competence in environmental engineering or science.

#### Fire Safety Professional

The Fire Safety Professional works to control and extinguish fires, rescue persons endangered by fire, and reduce or eliminate potential fire hazards. It also controls hazardous materials incidents, provides emergency medical services, trains personnel in fire protection and prevention, operates fire communications equipment, develops and implements fire protection and prevention plans, procedures, and standards and, advises on improvements to structures for better fire prevention.

#### Quality Assurance Representative I

A Quality Assurance Representative I independently inspects a few standardized procedures, items or operations of limited difficulty. A Quality Assurance Representative I's assignments involve independent record keeping and preparation of reports, inspection and testing, interpretation of plans and specifications and observation of construction activities to check adherence to safety practices and requirements. Quality Assurance Representative I's maintain work relationships with contractor supervisory personnel. Contacts involve obtaining information on sequence of operations and work methods, explaining standard requirements of plans and specifications, and informing the contractor of inspection results.

#### Quality Assurance Representative II

A Quality Assurance Representative II independently inspects a wide variety of standardized items or operations requiring a substantial knowledge of the method and techniques of construction inspection and of construction methods, equipment, materials, practices and the ability to interpret varied requirements in drawings and specifications. Quality Assurance Representative II's obtain information on schedules and work methods and explain requirements of plans and specifications. They make suggestions to the contractor concerning well-established acceptable methods and practices to assist the contractor in meeting standard requirements. Quality Assurance Representative II's are typically not authorized to approve deviations in construction plans, methods and practices even of a minor nature.

#### Quality Assurance Representative III

A Quality Assurance Representative III is expected to interpret plans and specifications relating to construction problems of normal difficulty, that is, those for which there are precedents and those without unusual complications. Quality Assurance Representative III's resolve differences between plans and specifications when such differences do not involve questions of cost or engineering design. Engineering and supervisory assistance is readily available and is provided as needed to assist in interpreting plans and specifications and in resolving differences involving complex problems. Technical assistance is also available on unusual specialized trade, crafts or materials problems. Inspection reports are reviewed for accuracy, completeness and adequacy. Unusually difficult and novel problems are discussed with the supervisor. Quality Assurance Representative III's are typically authorized to approve minor deviations in construction methods and practices which conform to established precedents, do not involve added costs, and are consistent with contract plans and specifications. Decisions by Quality Assurance Representative III's on the acceptability of construction methods and practices, workmanship, materials, and the finished product are considered to be final.