

A Publication of the  
National Wildfire  
Coordinating Group

# Fire Equipment Storage and Refurbishing Standards



**PMS 448**

**May 2011**

---



# Fire Equipment Storage and Refurbishing Standards

PMS 448  
May 2011

The National Wildfire Coordinating Group (NWCG) has approved this information for the guidance of its member agencies and is not responsible for the interpretation or use of this information by anyone except the member agencies.

Sponsored for NWCG publication by the Equipment Technology Committee.

Previous editions: Intermittent revisions since the initial 1992 edition. This 2011 edition replaces the 2007 edition.

**This document is posted at <http://www.nwcg.gov/pms/pubs/pubs.htm>**

Comments regarding the content of this document should be directed to: [eponder@fs.fed.us](mailto:eponder@fs.fed.us) or [mcnudde@fs.fed.us](mailto:mcnudde@fs.fed.us)

---

Prepared by Refurbishment Standards Unit, National Fire Equipment System Subcommittee, Equipment Technology Committee at the National Interagency Fire Center, 3833 S. Development Ave., Boise ID 83705.

Tory Henderson, Chair, Equipment Technology Committee

Paul Naman, Chair, National Fire Equipment System Subcommittee

Eve Ponder, Chair, Refurbishment Standards Unit

Additional recognition for the support by personnel from FS Technology and Development Centers in Missoula, MT and San Dimas, CA and the eleven National Interagency Support Caches: Northern Rockies, Missoula, MT; Rocky Mountain, Denver, CO; Southwest, Prescott, AZ and Silver City, NM; Great Basin, Boise, ID; Northern California, Redding, CA; Southern California, Ontario, CA; Northwest, Redmond, OR; Northeast, Grand Rapids, MN; Southern, Lexington, KY; and Alaska, Fairbanks, AK.

---

*NWCG information is in the public domain. Use of the information, including copying, is permitted. Use of NWCG information within another document is permitted, if NWCG information is accurately cited to the NWCG. The NWCG logo may not be used except on NWCG authorized information. "National Wildfire Coordinating Group", "NWCG", and the NWCG logo are trademarks of the National Wildfire Coordinating Group.*

*The use of trade, firm, or corporation names in this publication is for the information and convenience of the reader and does not constitute an endorsement by the National Wildfire Coordinating Group of any product or service to the exclusion of others that may be suitable.*

:

## **CONTENTS**

<u><b>ITEM</b></u>	<u><b>NFES #</b></u>	<u><b>PAGE</b></u>
<b>Introduction</b>		1
<b>Adapter, 1”</b>	000003, 000004,	
<b>Adapter, 1½”</b>	000006, 000007.....	3
<b>Applicator, water, 2-piece</b>	000720.....	4
<b>Axe, boy’s single bit, 24”handle, w/sheath</b>	000352	
<b>Axe, single bit, 4 lb w/sheath</b>	000707.....	5
<b>Axe, 5 lb, 26” straight handle w/sheath</b>	000383	
<b>Bag, backpack pump, with 2 liners &amp; couplings</b>	001197.....	7
<b>Bag, sleeping, cloth, washable, 3 lb fill</b>	000022	
<b>Bag, sleeping, cold weather, x-long</b>	000058.....	8
<b>Bag, sleeping, firefighters, 36” x 86”</b>	001062.....	9
<b>Bag, slingable, 72 GL, non-potable</b>	000426	
<b>Bag, slingable, 250 GL, non-potable</b>	006017	
<b>Bag, slingable, 360 GL, non-potable</b>	006021.....	10
<b>Bag, slingable, water, drinking, 55 GL</b>	000435.....	12
<b>Bag, slingable, water, suppression, 55 GL</b>	000437.....	13
<b>Bag, tent, personal gear pack</b>	000281.....	14
<b>Berm, containment, 55 GL (1 to 4 drums)</b>	000692	
<b>Berm, containment, MK III</b>	000693.....	15
<b>Blanket, bed, wool, 66” x 84”</b>	000441.....	16
<b>Blower, mist, leaf blower</b>	007040.....	17
<b>Can, gasoline, safety, 5 GL, DOT approved</b>	000606.....	19
<b>Can, 3 GL (3.8L), gas, safety, vented</b>	001290	
<b>Can, 5 GL (18.9L), gas safety, vented</b>	001291	
<b>Can, 2 GL, (3.8L), gas, safety, vented</b>	000350	
<b>Can, 5 GL (18.9L), gas, w/o spout, jeep</b>	001175.....	20
<b>Chain Saw, 20” – 24” bar</b>	000159.....	21
<b>Chaps, protective, summer weight</b>	000044, 000045, 000078, 000150.....	23
<b>Clamp, hose, shut-off, 1” – 1½” hoses</b>	000046.....	25
<b>Container, 1 liter, fuel, aluminum, red finish</b>	001535.....	26
<b>Container, fuel/oil, 2 compartment</b>	000741.....	27

## Fire Equipment Storage and Refurbishing Standards

---

<b>Cord</b> , extension, 50' or 100', AWG, 12/3 Wire	000560, 001172.....	28
<b>Cord</b> , light, 50' w/multiple light sockets, AWG	000563.....	29
<b>Cot</b> , folding, 12 oz cover, 3½' x 6½'	000053.....	30
<b>Couplings</b>	000710, 000855, 000856, 000857, 000916, 007027, 007028, 007618, 007619.....	31
<b>Extinguisher</b> , fire, 20A:120BC, 20 lb.	000307.....	32
<b>Fence</b> , barricade, plastic, 4' x 50' roll	000608.....	33
<b>Flight Suit</b>	000501, 000507, 000508, 000509, 000514, 000517, 000518, 000519, 000521, 000525, 000527, 000539, 000545, 000546, 000547, 000548, 000567, 000572, 000574, 000576	34
<b>Fly</b> , plastic, tent, 16' x 24' w/10 guy ropes	000070.....	35
<b>Fly</b> , sunscreen, 20' x 20' w/guy ropes	006131.....	36
<b>Fly</b> , tent, type II, 9' x 10'	001521.....	37
<b>Foam Unit</b> , round pump	007056.....	38
<b>Food</b> , Meals Ready-to-Eat (MRE)	001842.....	39
<b>Generator</b> , gas engine 3---6 KW w/ground rod	000709.....	41
<b>Harness</b> , chest, fire shelter	000294.....	43
<b>Headlamp</b> , firefighter's (advanced)	000667.....	44
<b>Headlamp</b> , single cell, cordless	000713.....	46
<b>Heater</b> , propane 20# tank mounted	006139	
<b>Heater</b> , propane, outdoor, 360° radiant heat	006187.....	47
<b>Helmet</b> , flight, SPH-5TPL	001214, 001215	
<b>Helmet</b> , flight, SPH-5C	002314, 002315.....	48
<b>Helmet</b> , safety, plastic w/chin strap	000109.....	49
<b>Hose</b> , garden, synthetic, ¾" NH x 50'	001016.....	50
<b>Hose</b> , lined	000932, 000933, 000966, 000967, 001238, 001239.....	51
<b>Hose</b> , synthetic, weeping	001873, 000334.....	53
<b>Hose</b> , suction	000115, 000652, 000914, 001808.....	55
<b>Hose Roller</b> , electric	000633.....	56
<b>Hose Roller</b> , gas	000665.....	57
<b>Increasesers</b>	000416, 002235, 000854.....	59

## Fire Equipment Storage and Refurbishing Standards

---

<b>Jean, BDU</b>	All sizes.....	60
<b>Kit, coffee heating</b>	000480.....	62
<b>Kit, first aid, 10-person, belt</b>	001143	
<b>Kit, first aid, type III, 24-person</b>	001604.....	63
<b>Kit, longline, with remote hook</b>	000243, 000398, 000849, 001309.....	64
<b>Hook, cargo, electric w/brush guard</b>	000243.....	65
<b>Connector, pigtail</b>	000398.....	67
<b>Longline, cable 50' with NEMA plugs</b>	000849.....	68
<b>Kit, shelter, 15' x 27'</b>	000430	
<b>Kit, shelter, 16' octagon</b>	000550	
<b>Kit, shelter, 18' octagon</b>	000540	
<b>Kit, shelter, 20' octagon</b>	000549.....	76
<b>Ladder, step 8' fiberglass</b>	000586.....	77
<b>Lantern, camp, electric, florescent</b>	002501.....	78
<b>Leadline, helicopter, external loads, 6,000 lb</b>	000380	
<b>Leadline, helicopter, external loads, 3,000 lb</b>	000528.....	79
<b>Litter, S.K.E.D.</b>	001670.....	86
<b>McLeod, with plastic sheath, 11" wide</b>	000296.....	87
<b>Net, cargo, 12' x 12', polypropylene, 3,000 lb</b>	000531	
<b>Net, cargo, 15' x 15', 6,000 lb</b>	000458	
<b>Net, cargo, lightweight, 10' x 10', 300 lb</b>	000695.....	88
<b>Nozzle, combination, barrel, KK 1" &amp; 1½"</b>	001081, 001082	
<b>Nozzle, plastic, 35 GPM 1" &amp; 60 GPM 1½"</b>	000137, 000138.....	89
<b>Nozzle, fire foam, 8 GPM, 16 GPM, 30 GPM, plastic</b>	000627, 000628, 000629.....	90
<b>Nozzle, garden, hose ¾"</b>	000136.....	91
<b>Nozzle, twin tip, combination 1" NPSH-F</b>	000024.....	92
<b>Pack, fireline, blue complete</b>	000674	
<b>Pack, field, firefighter, unisex, complete</b>	001372	
<b>Pack, personal gear</b>	001855	
<b>Packsack, waterproof, w/straps</b>	000744.....	93
<b>Pad, sleeping, gray foam, ¾" x 23" x 75"</b>	001566.....	94
<b>Pole, ridge, 16'</b>	000089.....	95
<b>Pole, upright adjustable</b>	000083.....	96
<b>Pulaski, with plastic sheath</b>	000146.....	97

## Fire Equipment Storage and Refurbishing Standards

---

<b>Puller</b> , fence	000011.....	98
<b>Pump</b> , lightweight, 2 cycle	000124, 00253.....	99
<b>Pump</b> , lightweight, 4 cycle	006000.....	101
<b>Pump</b> , high pressure w/fuel line	000148.....	103
<b>Pump</b> , 1½” floating, waterous	007646.....	106
<b>Pump</b> , 1½” Multiquip, 5.5 HP	007647.....	108
<b>Pump</b> , 2½”, 6.5 – 13HP Centrifugal	007648.....	110
<b>Pump</b> , portable, Wick - 250	007650.....	112
<b>Pump</b> , volume, trash 2”	000683, 001222.....	114
<b>Pump</b> , trombone, backpack, single action	000151.....	116
<b>Rake</b> , collapsible	000659.....	117
<b>Rake</b> , fire (council tool), w/sheath	001807.....	118
<b>Reducers</b>	000009, 000010, 000417, 000418, 000685, 000733, 002229, 002230, 000402.....	119
<b>Shelter</b> , fire, complete	<del>000169</del> .....	120
<b>Shelter</b> , fire, complete, M-2002 (blue)	000925	
<b>Shelter</b> , fire, M-2002	000926	
<b>Case</b> , carrying, fire shelter, M-2002	000927	
<b>Liner</b> , fire, shelter carrying case, M-2002	000928.....	121
<b>Shelter</b> , fire, practice, complete, M-2002	002678	
<b>Shelter</b> , fire, practice M-2002	002679	
<b>Polyvinyl Bag</b> , practice fire shelter, M-2002	002681	
<b>Case</b> , carrying, fire shelter, practice, M-2002	002680	
<b>Liner</b> , fire shelter carrying case	000928	
<b>Shelter</b> , fire, practice	002407.....	123
<b>Shirt</b> , fire	All Sizes .....	125
<b>Shovel</b> , w/plastic sheath, #1	000171.....	126
<b>Shroud</b> , face & neck, Nomex® w/front closure	001274.....	127
<b>Spout</b> , gas, flexible, 16”, steel	000210.....	128
<b>Swatter</b> , fire	001868.....	129
<b>Swivel</b> , cargo, 3,000 lb capacity	000526	
<b>Swivel</b> , cargo, 6,000 lb capacity	000286.....	130
<b>Table</b> , mess, 4-person	001390	
<b>Table</b> , folding	002698.....	136

## Fire Equipment Storage and Refurbishing Standards

---

<b>Tank</b> , collapsible, 1,000 GL	000588	
<b>Tank</b> , collapsible, 1,200 GL	000090	
<b>Tank</b> , collapsible, 1,500 GL	000589	
<b>Tank</b> , collapsible, 1,800 GL	000668	
<b>Tank</b> , collapsible, 3,000 GL	000568	
<b>Tank</b> , collapsible, 4,800 GL	006030	
<b>Tank</b> , collapsible, 6,000 GL	006031.....	137
<b>Tank</b> , dip, 15,000 GL, Heliwell	000669.....	138
<b>Tank</b> , folding, 1,000 GL, w/frame	000661	
<b>Tank</b> , folding, 1,500 GL, w/frame	000664.....	139
<b>Tank</b> , gasoline, 5 GL, pump adapted	000218.....	140
<b>Tank</b> , propane, fuel, LPG, 20 lb tank (5 GL)	000491.....	141
<b>Tank</b> , Snaptank, 1500 GL and 1000 GL	007700, 007614.....	142
<b>Tees</b> , hoseline	000230, 000731, 001809, 002240.....	143
<b>Tent</b> , 2-person	000077.....	144
<b>Tent</b> , wall, 14' x 16', without poles	000084.....	145
<b>Tip</b> , applicator, 3 GPM & 15 GPM	000735, 000736	
<b>Tip</b> , nozzle, straight stream and fog	000635, 000636, 000637, 000638, 000094, 000737 .....	146
<b>Tool</b> , combination shovel and grub hoe	001180.....	147
<b>Torch</b> , drip, 1¼ GL	000241.....	149
<b>Valve</b> , auto check and bleeder	000228.....	152
<b>Valve</b> , foot, 1½" NH-F w/strainer	000212	
<b>Valve</b> , foot, 2" NPSH w/strainer	000906.....	153
<b>Valve</b> , pressure relief, 1½" NH-F	000229.....	154
<b>Valve</b> , shut off, ball	001201, 001207, 000738.....	155
<b>Valve</b> , wye, gated	000259, 000231, 000272.....	156
<b>Wye</b> , plain	000739, 000839, 000883.....	158
<b>APPENDIX A</b>		<b>A-1</b>
• Cleaning Instructions		A-3
• Nomex Clothing Exposed to Poison Oak/Ivy/Sumac		A-5
• Quality Assurance by Lot Sampling		A-6
• NFES Refurbishment Standard Change, Add or Delete Proposal form		A-9
• NFES Refurbishment Standard Quality Complaint form		A-10





## Introduction

This document addresses specific fire equipment items used within the National Fire Equipment System (NFES). These national standards are applicable at local units. For items that are not identified for refurbishment in this guide, contact your local servicing cache for questions and/or disposition.

As new items are introduced, current items are discontinued and/or health and safety issues arise, this document will be revised to provide updated information.

A few overall equipment-refurbishing protocols should be used *when applicable*:

- Mark items with testing/inspection dates.
- Package items in sealed bags or “zip-tied”. This will help determine if the item has been used when returned. For example, place nozzles, tee’s, valves in a sealed bag. If the seal is not broken, the item should only need a visual inspection. “Zip-tie” the starter ropes on a chainsaw to the saw. If it is still “zip-tied” when returned, there is no need to refurbish the chainsaw.
- Clean, sanitize, rinse and air dry any items used for transport, consumption or storage of potable water or food. Clean items with a mild detergent and water. Sanitize items rinsing with mixture of 1 ounce or 1 tablespoon of chlorine bleach thoroughly mixed into a gallon of room-temperature water. Rinse with clean water, drain, and air dry.
- If items are exposed to the human body, clean and dry using the specific instructions in this document. Examples are Nomex® clothing, neck shrouds, sleeping bags, sleeping pads, and cots. Failure to follow the cleaning instructions may result in the failure of the fabric or materials to correctly or safely perform its function. This procedure also prevents the spread of communicable diseases.
- Dispose of hazardous materials according to local health and safety regulations.
- Repackage items using the standards set forth in this document.
- If there is a question, the cache manager or the supervisor has the responsibility for determining whether it is economical to refurbish or dispose of an item.
- Recycle as local options are available.

Users should inspect all items that have been refurbished using some measure for quality assurance. Appendix A provides an explanation and example of statistical sampling by Missoula Technology and Development Center (MTDC).

Abbreviations used in this document:

DLT—date last tested

GL—gallon

lb--pound

PSI—pounds per square inch

RPM—revolutions per minute



## Fire Equipment Storage and Refurbishing Standards

---

ITEM: **ADAPTER, 1”**  
**ADAPTER, 1½”**

NFES #000003, #000004  
NFES #000006, #000007

**A. Initial Inspection/Disposal Criteria**

1. Inspect for cracks and large burrs, if any dispose of.
2. Inspect for fire damage, burn marks or melted areas, if any dispose of.
3. Inspect threads for damage, if threads are crossed or show signs of excessive wear (loose fitting or hard to connect to other fittings), dispose of.

**B. Tests -- none**

**C. Refurbishing Procedures**

1. Replace gasket if missing, cracked, damaged, or stiff.
2. If male threads are damaged try using a triangle file to remove burrs or dings. If threads don't fit smoothly, dispose of.

**D. Retesting Criteria -- none**

**E. Cleaning Procedures**

1. Clean in parts washer, high pressure wash with warm water and a mild detergent using a brush or scouring pad.
2. Rinse in clean water and let dry.

**F. Repackaging**

1. Package to protect threads.
2. Pack 10 each in carton (cache option) or 60 each in carton (cache option) and label accordingly.

**G. Storage and Shelf Life Checks -- none**

**H. Recycle as local options are available.**

**I. References**

[Water Handling Equipment Guide, NWCG PMS 447-1](http://www.nwcg.gov/pms/pubs/WHEG03.pdf)  
<http://www.nwcg.gov/pms/pubs/WHEG03.pdf>

## Fire Equipment Storage and Refurbishing Standards

---

ITEM: **APPLICATOR**, water, 2-piece

NFES #000720

**A. Initial Inspection/Disposal Criteria**

1. Inspect for cracks and large burrs, if any dispose of.
2. Inspect for fire damage, burn marks or melted areas, if any dispose of.
3. Inspect threads for damage, if threads are crossed or show signs of excessive wear (loose fitting or hard to connect to other fittings), dispose of.
4. Inspect for gaskets in female fittings, if missing replace gasket.

**B. Tests**

1. Assemble 2-piece applicator.
2. Inspect for visual signs of wear and tear.

**C. Refurbishing Procedures**

Replace gaskets if missing.

**D. Retesting Criteria -- See B. Tests.**

**E. Cleaning Procedures**

1. All items will be washed and cleaned of mud, dirt, and grease.
2. Clean with a mild detergent with bristle brush or scouring pad; pressure wash as needed.
3. Rinse thoroughly and let dry.

**F. Repackaging**

Package 12 each in NFES #000385 and label accordingly.

**G. Storage and Shelf Life Checks -- none**

**H. Recycle as local options are available.**

## Fire Equipment Storage and Refurbishing Standards

---

ITEM: AXE, boy's single bit, 24" handle, w/sheath	NFES #000352
AXE, single bit, 4 lb w/sheath	NFES #000707
AXE, 3 – 5 lb, 26" straight handle w/sheath	NFES #000383

### A. Initial Inspection/Disposal Criteria

1. Inspect for obvious damage to head, cutting edges, contains metal wedges, if so dispose of.
2. Inspect for large chips in blade or cracked head eye, if so dispose of.
3. Dispose of if any modifications to head, such as rivets through side of head to hold handle.

### B. Tests

1. Head-- blades have not been tapered or rounded to point that tool cannot be sharpened properly.
2. Handle.
  - a. Twisted, bent, or open-grain handle.
  - b. Grasp the handle of the tool 2 – 4" from the end with the head hanging down, but not touching the ground. Using a ball peen or similar hammer, give the end of the handle a firm smack. Listen to the sound it makes. If the head is tight and the handle free of defect, it will make a clear ringing sound. If it is loose or defective, you will hear a dull thud like hitting the end of a 2 x 4.

### C. Refurbishing Procedure

1. Head.
    - a. Clean head.
    - b. Sharpen tool to specifications according to tool sharpening gauge NFES# 000510.  
✓ **CAUTION—Tool should never be ground to the degree that the metal temperature rises high enough to remove temper, i.e., blue or burned edges.**
    - c. Ensure that blade corners are square.
    - d. Paint tool head with rust inhibitor (cache option.)
  2. Handle.
    - a. Visually Inspect handle.
    - b. Sand handle if it is rough, chipped, dinged, or has any type of residue that did not come off during sanding.
    - c. When replacing handle, shape eye for a snug fit. Use high impact plastic or wood-type wedges with appropriate type of epoxy.
    - d. The bottom of the tool head should be within  $\frac{3}{8}$ "-- $\frac{5}{8}$ " of the shoulder of the handle.
    - e. Cut excess off handle, flush with tool head after inserting wedge into handle.
    - f. Wipe handle with rag and linseed oil.
- ✓ **NOTE: Metal wedges can be added only in the field as an emergency measure for field refurbishing.**

### D. Retesting Criteria -- none

### E. Cleaning Procedures -- See C. Refurbishing Procedure.

## Fire Equipment Storage and Refurbishing Standards

---

Continued--

ITEM: <b>AXE</b> , boy's single bit, 24" handle, w/sheath	NFES #000352
<b>AXE</b> , single bit, 4 lb w/sheath	NFES #000707
<b>AXE</b> , 3 – 5 lb, 26" straight handle w/sheath	NFES #000383

**F. Repackaging**

1. For NFES #000707 install sheath (no NFES).  
    Package 12 each in carton NFES #000338 (37" X 18" X 8") (NSN 8115-00-139-0673).
2. For NFES #000352 install leather sheath NFES #000359.  
    Package 12 each in appropriate size carton (until an appropriate size is found).
3. For NFES #000383 install sheath NFES #000815. Package per local cache requirements.

**G. Storage and Shelf Life Checks**

Per local cache requirements to ensure proper serviceability of tools.

**H. Recycle as local cache options are available**

**I. References**

New and Improved Flap Cup Grinder Disc for Sharpening Fire Handtools, Fire Management Tech Tips, USDA FS SDTDC 0251 1305-SDTDC, June 2002 [New and Improved Flap Cup Grinder Disc](#)

---

## Fire Equipment Storage and Refurbishing Standards

---

ITEM: **BAG**, backpack pump, with 2 liners & couplings

NFES #001197

**A. Initial Inspection/Disposal Criteria**

1. Fabric and webbing.
  - a. Inspect for any holes, cuts, tears, burns, or torn seams that are not economically repairable, if any dispose of.
  - b. Inspect for any fastener missing or that does not provide adequate closure, replace.
  - c. Inspect for excessive dirt or fuel stain that cleaning cannot eliminate, dispose of.
  - d. Inspect for any writings, drawings, and if so dispose of item.

**B. Tests -- none**

**C. Refurbishing Procedures**

1. Replace nonfunctioning hardware.
2. Take new plastic liner out of pouch and replace old liner, insert a new liner into pouch, NFES #000597.
3. Install rubber gasket on cap, to prevent leakage.
4. Replace O-ring.

**D. Retesting Criteria -- none**

**E. Cleaning Procedures**

See Appendix A--Cleaning Instructions.

**F. Repackaging**

Pack 10 each in carton (local cache option).

**G. Storage and Shelf Life Checks -- none**

**H. Recycle as local options are available.**

---

## Fire Equipment Storage and Refurbishing Standards

---

ITEM: **BAG**, sleeping, cloth, washable, 3 lb fill  
**BAG**, sleeping, cold weather, X-long

NFES #000022  
NFES #000058

**A. Initial Inspection/Disposal Criteria**

1. Inspect for any holes, cuts, tears, abrasions, or torn seams that cannot be repaired economically, if any dispose of.
2. Inspect for excessive dirt or stains that laundering cannot eliminate, if any dispose of.
3. Inspect for missing slider, damaged coils, or other defects that make zipper inoperable, repair if economical.
4. Inspect for batting that is bunched-up or in clumps. Shake the bag several times to ensure that the batting will loft evenly, not clump or shift.
5. Inspect for any indelible marking on the bag, if any dispose of.
5. Inspect for any signs of body fluid stains. If there's any question on whether the bag can be completely cleaned and sanitized, dispose of the item.

**B. Tests**

1. Inspect cord lock to ensure spring works properly and that the cord passes freely through when the lock is disengaged.
2. Close zipper to ensure it provides a smooth and secure closure the full length of the bag opening.
3. Open and close the hook and pile fastener to ensure closure is adequate.

**C. Refurbishing Procedures**

1. Repair any hole, cut, tear, abrasion, or open seam.
2. Remove excessive dirt or stains by air drying and brushing with a soft bristle brush.
3. Replace any zipper that has damaged coils and replace any missing slider.
4. Inspect loft of batting in bags prior to sending for laundering.

**D. Retesting Criteria**

Retest all replacement hardware.

**E. Cleaning Procedures**

See Appendix A--Cleaning Instructions.

**F. Repackaging**

1. Package 5 bags in carton NFES #000644 (NSN 8115-00-139-0691).
2. Package in plastic bag.

**G. Storage and Shelf Life Checks**

1. Prior to shipping, inspect carton for rodent damage. If found, handle accordingly and dispose of carton and contents in appropriate manner.



---

## Fire Equipment Storage and Refurbishing Standards

---

ITEM: **BAG**, sleeping, firefighters, 36" x 86"

NFES #001062

**A. Initial Inspection/Disposal Criteria**

1. Inspect for any holes, cuts, tears, abrasions, or torn seams that cannot be repaired economically, if any dispose of.
2. Inspect for excessive dirt or stains that laundering cannot eliminate, if any dispose of.
3. Inspect for batting that is bunched-up or in clumps. Shake the bag several times to ensure that the batting will loft evenly and not clump or shift.
4. Inspect for any indelible marking on the bag, if any dispose of.
5. Inspect for any signs of body fluid stains. If there's any question on whether the bag can be completely cleaned and sanitized, dispose of the item.

**B. Tests**

1. Inspect cord lock to ensure spring works properly and that the cord passes freely through when the lock is disengaged.
2. Open and close the hook and pile fastener to ensure closure is adequate.

**C. Refurbishing Procedures**

1. Repair any hole, cut, tear, abrasion, or open seam.
2. Remove excessive dirt or stains by air drying and brushing with a soft bristle brush.
3. Inspect loft of batting in bags prior to sending for laundering.

**D. Retesting Criteria**

Retest all replacement hardware.

**E. Cleaning Procedures**

See Appendix A--Cleaning Instructions.

**F. Repackaging**

Cache option: Package 10 bags in carton NFES #000513 (NSN 8115-01-290-9543).

Package in plastic bag.

**G. Storage and Shelf Life Checks**

Prior to shipping, check carton for rodent damage. If found, handle accordingly and dispose of the carton/contents appropriately.

---

## Fire Equipment Storage and Refurbishing Standards

---

ITEM: <b>BAG</b> , slingable, water, 72 GL, non-potable	NFES #000426
<b>BAG</b> , slingable, water, 250 GL, non-potable	NFES #006017
<b>BAG</b> , slingable, water, 360 GL, non-potable	NFES #006021

### A. Initial Inspection/Disposal Criteria

1. Separate by NFES #.
2. Visually inspect for missing components, or need for repair such as: straps, hoses, spigot, cap, and gasket.

### B. Tests

1. Fill with air to test for leaks.
2. Visually inspect bags for rips, tears, or obvious defects.
3. Use a black permanent marker to indicate damage, keeping all markings simple and professional.

### C. Refurbishing Procedures

1. Clean area around damaged spot with lacquer thinner or other suitable cleaner.  
✓ **CAUTION: Utilize well-ventilated area.**
2. Apply suitable glue (manufacturer's recommendation) to both surfaces (patch and tank).
3. Let dry until tacky.
4. Place patch on damaged area and apply pressure with roller or suitable device for at least 1 minute.
5. Repair or replace any damaged components.
6. Clean exterior of tank thoroughly (with filler cap attached).
7. Support or hang tank with spigot closed, remove cap and fill with water to rinse out tank.
8. Replace cap.
9. Shake tank vigorously until all foreign matter is removed.
10. Drain tank completely through hose and spigot.
11. Invert tank after removing cap, open spigot and empty as much water as possible.
12. Let dry inverted for 1 hour in sun, if possible.
13. Ensure bags are stenciled with "non-potable" or "suppression use only".

### D. Retesting Criteria

1. Re-inspect any patches or repairs.
2. Replace cap and close spigot.

### E. Cleaning Procedures

1. Clean exterior of tank thoroughly with filler cap attached.
2. Support or hang tank with spigot closed, remove cap and fill with water to rinse out tank.
3. Replace cap and shake bag vigorously until all foreign matter is removed.
4. Drain completely through hose and spigot.
5. Invert bag after removing cap, open spigot and empty as much water as possible.
6. Let dry inverted for 1 hour in sun, if possible.

## Fire Equipment Storage and Refurbishing Standards

---

Continued--

ITEM: <b>BAG</b> , slingable, water, 72 GL, non-potable	NFES #000426
<b>BAG</b> , slingable, water, 250 GL, non-potable	NFES #006017
<b>BAG</b> , slingable, water, 360 GL, non-potable	NFES #006021

**F. Repackaging**

1. Ensure that tank is stenciled visibly with the words “NON-POTABLE” or SUPPRESSION USE ONLY” and proper NFES # is stenciled on tank.
2. Use carton (cache option) for NFES #000426 and label accordingly.  
Use carton (cache option) for NFES #006017 and label accordingly.  
Use carton (cache option) for NFES #006021 and label accordingly.

**G. Storage and Shelf Life Checks -- none**

**H. References**

<http://www.sei-ind.com>

**I. Recycle as local options are available.**

---

## Fire Equipment Storage and Refurbishing Standards

---

ITEM: **BAG**, slingable, water, drinking, 55 GL (208.2L)

NFES #000435

### **A. Initial Inspection/Disposal Criteria**

1. Dispose of nylon outer bag if there are--
  - a. Any holes, cuts, tears, burns, or torn seams not economically repairable.
  - b. Any zipper or Velcro closures do not close properly.
  - c. Unightly dirt or fuel stain that cleaning cannot eliminate.
  - d. Buckle does not function properly (repair, replace or dispose.)
2. Fill and drain hardware.  
Replace or repair any part missing or damaged.
3. Liners.
  - a. Replace old liner and make sure plugs are tightly threaded onto fitment caps to keep new liner sanitary.
  - b. Inspect condition of spare liner. Unless the integrity of the liner is in question, do not remove from the sealed bag to make this inspection.

### **B. Tests**

1. Test fill and drain fittings for proper function and tight seal. The fill fitting is the special hardware that keeps dirt and bacteria out of the liner.
2. Test buckles by fastening and unfastening. They should function easily with little force applied and with no difficulty in the release.
3. Test zippers and velcro by opening and closing. Zipper should operate smoothly over its full length. Velcro hook and pile should adhere to one another.

### **C. Refurbishing Procedures**

1. Repair holes, cuts, tears, and broken seams.
2. Replace nonfunctioning buckles.
3. Replace used liners (NFES #000436).
4. Replace missing or damaged fittings.

### **D. Retesting Criteria**

Test any replacement buckle, or fitting as specified in C. Refurbishing Procedures.

### **E. Cleaning Procedures**

1. See Appendix A--Cleaning Instructions.
2. Filling and draining hardware.
  - a. Wash thoroughly in a solution of chlorine bleach, consisting of 1-ounce bleach per gallon of water.
  - b. Rinse in potable water and dry completely.
  - c. Once hose and fittings are sanitized and dried, reseal in a plastic storage bag and put in zipper pocket.

### **F. Repackaging**

Local cache option

### **G. Storage and Shelf Life Checks -- none**

### **H. Recycle as local cache options are available.**

ITEM: **BAG**, slingable, water, suppression, 55 GL

NFES #000437

**A. Initial Inspection/Disposal Criteria**

1. Dispose of nylon outer bag if there are--
  - a. Any holes, cuts, tears, burns, or torn seams not economically repairable.
  - b. Any zipper or Velcro closures do not close properly.
  - c. Unsightly dirt or fuel stain that cleaning cannot eliminate.
  - d. Buckle does not function properly (repair, replace or dispose.)
2. Fill and drain hardware.  
Replace or repair any part missing or damaged.
3. Liners.
  - a. Replace old liner and make sure plugs are tightly threaded onto fitment caps.
  - b. Inspect condition of spare liner. Unless the integrity of the liner is in question, do not remove from the sealed bag to make this inspection.

**B. Tests**

1. Test fill and drain fittings for proper function and tight seal.
2. Test buckles by fastening and unfastening. They should function easily with little force applied and with no difficulty in the release.
3. Test zippers and Velcro by opening and closing. Zipper should operate smoothly over its full length. Velcro hook and pile should adhere to one another.

**C. Refurbishing Procedures**

1. Repair holes, cuts, tears, and broken seams.
2. Replace nonfunctioning buckles.
3. Replace used liner and place additional liner in pocket (NFES #000438).
4. Replace missing or damaged fitting parts.

**D. Retesting Criteria**

Test any replacement buckle, zipper, or fitting as specified in C. Refurbishing Procedures.

**E. Cleaning Procedures**

See Appendix A--Cleaning Instructions

**F. Repackaging**

Local cache option.

**G. Storage and Shelf Life Checks -- none**

**H. Recycle as local cache options are available.**

ITEM: **BAG**, tent, personal gear pack

NFES #000281

**A. Initial Inspection/Disposal Criteria**

1. Fabric and webbing.
  - Inspect for any holes, cuts, tears, burns, or torn seams that are not economically repairable, if any dispose of.
2. Inspect for and replace any fastener missing or that does not provide adequate closure.
3. Inspect for excessive dirt or fuel stain that cleaning cannot eliminate, dispose of.
4. Any zipper that does not close properly should be replaced if economical, otherwise dispose of.
5. Inspect for any writings, drawings, if any dispose of.

**B. Tests**

1. Test hardware by fastening and unfastening the item. The hardware should function easily with little force being applied and with no difficulty in the release.
2. Open and close zipper to test. The zipper should operate smoothly through its full length.

**C. Refurbishing Procedures**

1. Repair holes, cuts, or tears.
2. Replace nonfunctioning hardware, if economical.

**D. Retesting Criteria -- none**

**E. Cleaning Procedures**

See Appendix A--Cleaning Instructions.

**F. Repackaging**

Package 20 bags in carton.

**G. Storage and Shelf Life Inspects -- none**

---

## Fire Equipment Storage and Refurbishing Standards

---

ITEM: **BERM**, containment, 55 GL (1 to 4 drums)  
**BERM**, containment, 15 GL

NFES #000692  
NFES #000693

**A. Initial Inspection/Disposal Criteria**

1. Inspect for fuel or other liquids which may be present.
2. Use absorbent cloth or similar to pick up excess fluids.
3. Dispose of soiled absorbent according to local hazardous materials standards.
4. Inspect for small holes, rips or tears and repair if economical and mark with felt tip pen or other means of identification.

**B. Tests**

Hold up to strong light or sun to locate holes.

**C. Refurbishing Procedures**

Clean and repair as stated in *Manufacturing Guidelines for Use and Repair*.

**D. Retesting Criteria -- none**

**E. Cleaning Procedures**

1. Clean with pressure washer to remove matter such as mud, dirt, and grease.
2. Use a solution of mild detergent and water to remove grease with an absorbent cloth.
3. Dispose of saturated cloth according local hazardous materials standards.

**F. Repackaging**

Roll berm and band for storage. Local cache option.

**G. Storage and Shelf Life Checks**

Store in a dry environment.

**H. Reference**

SE1 Industries  
7400 Wilson Avenue  
Delta, BC, Canada V4G 1F5  
Phone: 604-946-3131  
Web site: <http://www.sei-ind.com>

## Fire Equipment Storage and Refurbishing Standards

---

ITEM: **BLANKET**, bed, wool, 66" x 84"

NFES #000441

**A. Initial Inspection/Disposal Criteria**

1. Inspect for visible rips, burns, or tears, mend if economically feasible, if not dispose of.
2. Inspect for possible mildew, if so dispose of.

**B. Tests -- none**

**C. Refurbishing Procedures -- none**

**D. Retesting Criteria -- none**

**E. Cleaning Procedures**

Wool blankets must be DRY CLEANED ONLY.

**F. Repackaging**

1. Individually pack in plastic or waterproof bag.
2. Pack 15 each in carton NFES #000644 (33" X 16" X 22") (NSN 8115-00-139-00691).

**G. Storage and Shelf Life Checks -- none**



ITEM: **BLOWER**, mist, leaf blower

NFES #007040

**A. Initial Inspection/Disposal Criteria**

✓ NOTE: Follow the manufacturer's safety precautions as listed in the owner's manual prior to operation of this item.

1. Visually inspect for evidence of use (dust, oil, starter seal broken), damage or missing parts.
2. Return to stock if: there is no sign of use or damage and date last tested (DLT) does not exceed 12 months.
3. Refurbish as necessary if unit has been used, damaged, or shelf life is exceeded.

✓ If unit is not economically repairable it should be disposed of using local agency policy.

**B. Tests**

✓ NOTE: Refer to the owner's manual for operations and specifications information specific to blower model.

✓ Check condition of fuel mix; ensure fuel is fresh and the correct mix oil ratio is used for running tests (see G. Storage and Shelf-life Checks.) Recommendation: Use a fuel stabilizer in fuel during testing to help ensure proper operation of engine at post storage start up.

1. Test function of rewind starter, ensure proper engagement of engine and recoil functionality. Check for damage or fraying of pull cord; repair or replace as necessary.
2. Engine should: start easily, run smoothly, be free from fuel leaks, and provide sufficient power to the blower attachment. Ensure engine operational controls are functioning properly; stop switch, throttle and choke.
3. Test for blower performance (see owner's manual for specific performance data).

**C. Refurbishing Procedures**

This equipment is primarily serviced at a "factory authorized" repair facility. Ensure that the servicing repair facility has a copy of this refurbishment standard. Ensure B. Tests are completed.

**D. Retesting**

1. Retest if date last tested (DLT) is exceeded or starter seal is broken.
2. Ensure C. Refurbishing Procedures is completed.

**E. Cleaning Procedures**

1. Remove dirt, oil and grease, using detergent or degreaser as necessary (use pressure washer to remove heavy soil).
2. Use pressure washer only if you will start and run the blower the same day.

**F. Repackaging**

1. Use nylon "zip-tie" to tie off (seal) starter rope (to later determine if equipment has been used).
2. Attach certification tag; that indicates date last tested (DLT), property #, and name of individual certifying performance.
3. Ensure that all identification (property #, serial #, owner ID) is affixed and legible.

Continued --

ITEM: **BLOWER**, mist, leaf blower

NFES #007040

**G. Storage and shelf life checks**

- ✓ Recommendation: Use a fuel stabilizer in fuel during testing to help ensure proper operation of engine at post storage start up.

Ensure that date last tested (DLT) does not exceed 12 months.

**H. References**

[www.snapper.com](http://www.snapper.com)

[www.stihlusa.com](http://www.stihlusa.com)

[www.solousa.com](http://www.solousa.com)

## Fire Equipment Storage and Refurbishing Standards

---

ITEM: CAN, gasoline, safety, 5 GL, DOT approved

NFES #000606

### A. Initial inspection/Disposal Criteria

✓ *NOTE: Dispose of contaminated fuel according to hazardous material regulations in your area.*

1. Inspect for fuel and dispose of properly.
2. Inspect for leaks or separation along seams.
3. Inspect all threads on nozzles for serviceability.
4. Inspect for proper labeling.
5. Inspect all cotter keys and pins.
6. Ensure that containers are properly marked and labeled.  
[USDA Forest Service: Fuel Transport, Index](#)
7. Ensure spark arrester screen is present, replace as necessary.

### B. Tests

1. Visible inspection only.
2. Dispose of unserviceable cans.

### C. Refurbishing Procedures

1. Drain all existing fuel.
2. Use a rag and air hose to dry the interior of the container.
3. Turn upside down with lids off or open to dry.
4. Replace any defective cotter key or pins.
5. Inspect spring closure devices to be sure they are functioning properly.
6. Secure proper spout to top of can ( $\frac{3}{4}$ " on old style NFES #007033 and 1" on new style NFES #000706).
7. Visually verify that no rust exists inside container.
8. Wipe down outside of container and repaint if necessary.
9. Ensure container is properly marked and labeled.

### D. Retesting Criteria -- none

### E. Cleaning Procedures

See C. Refurbishing Procedures.

### F. Repackaging

Package according to DOT standards.

### G. Storage and Shelf Life Checks

Annual visual inspection for rust

### H. Reference

Replacement parts available from:

SAFE-T-WAY

National Sales Office

PO Box 1188

Salem, OR 44460

Web site: <http://www.safewayproductsinc.com/index.htm>

Phone: 330-332-3200

Fax: 330-332-2340

Fax order entry: 800-721-7216

## Fire Equipment Storage and Refurbishing Standards

---

ITEM: CAN, 3 GL (3.8L), gas, safety, vented	NFES #001290
CAN, 5 GL (18.9L), gas, safety, vented,	NFES #001291
CAN, 1 GL (3.8L), gas, safety, vented	NFES #000350
CAN, 5 GL (18.9L), gas, w/o spout, Jeep	NFES #001175

### A. Initial Inspection/Disposal Criteria

✓ NOTE: Dispose of contaminated fuel according to local hazardous material regulations.

1. Inspect for fuel and dispose of properly.
2. Inspect for leaks or separation along seams.
3. Inspect all threads on nozzles for serviceability.
4. Inspect for proper marking and labels. [USDA Forest Service: Fuel Transport, Index](#)
5. For NFES #001290 and #001291--
  - a. ensure spark arrester screen is present
  - b. replace as necessary.

### B. Tests

1. Inspect visually.
2. Dispose of unserviceable cans including those with unidentifiable contents.

### C. Refurbishing Procedures

1. Drain all existing fuel.
2. Use a rag and air hose to dry the interior of the container.
3. Turn upside down with lids off or open to dry.
4. Inspect vent hole to ensure it is clean and serviceable.
5. Visually verify that no rust exists inside container.
6. Wipe down outside of container and repaint if necessary.
7. Ensure containers are properly marked and labeled.

### D. Retesting Criteria -- none

### E. Cleaning Procedures

See C. Refurbishing Procedures.

### F. Repackaging

Local cache option

### G. Storage and Shelf Life Checks

Annual visual inspection for rust.

### H. Recycle as local cache options are available.

### I. Reference

<http://fsweb.mtdc.wo.fs.fed.us/fueltran/>

Interagency Transportation Guide for Gasoline, Mixed Gas, Drip-Torch Fuel, and Diesel, NWCG PMS 442 <http://www.nwcg.gov/pms/pubs/large.html#442>

ITEM: **CHAIN SAW**, 20” – 24” bar

NFES #000159

**A. Initial Inspection/Disposal Criteria**

- ✓ NOTE: Follow the manufacturer’s safety precautions as listed in the owner’s manual prior to operation of this item.
- ✓ If unit is not economically repairable it should be disposed of using local agency policy.
  1. Visually inspect for evidence of use (dust, oil, starter seal broken), damage or missing parts.
  2. Return to stock if: there is no sign of use or damage and date last tested (DLT) does not exceed 12 months.
  3. Refurbish as necessary if unit has been used, damaged, or shelf life is exceeded.

**B. Tests**

- ✓ NOTE: Refer to the owners’ manual for operations and specifications information specific to chainsaw model.
  1. Check condition of fuel and bar oil to ensure fuel is fresh and oil level is sufficient for running tests. See G. Storage and Shelf-life Checks.
  2. Start saw and allow engine to warm-up at idle.
  3. Ensure that there are no leaks at engine, fuel tank or bar oil reservoir.
  4. Run saw and inspect for proper function of bar oiler and chain brake.
  5. Ensure all engine controls are operational.
  6. Inspect engine speed using a digital tachometer, adjust carburetor to obtain specified speed.
  7. If saw chain rotates at the specified idle speed, inspect clutch for loose and or missing springs.

**C. Refurbishing Procedures**

1. Clean unit as necessary. See E. Cleaning Procedures.
2. Check for loose or missing parts and mounting hardware: tighten or replace as necessary
3. Ensure that the air filter is clean and dry before reinstalling. Replace the filter if it is damaged or will not come clean.
4. Replace spark plug and fuel filter if saw has been used.
5. Test function of rewind starter, ensure proper engagement of engine and recoil functionality. Check for damage or fraying of pull cord; repair or replace as necessary.
6. Clean muffler of excess carbon.
7. Inspect spark arrestor screen for build up: clean, repair or replace as necessary.
8. Replace sprocket or star drum if the wear is deep enough to catch a fingernail.
  - Inspect clutch shoes and springs. Replace if burned or missing.
  - Replace clutch drum if badly burned (discolored).
9. Ensure saw chain is properly sharpened to manufacturer’s specifications after each use.
  - Replace chain if: it has been filed down to 50% or less of the original cutter length; two or more cutters are broken; tie straps are worn down to rivets; if stretched beyond tensioning abilities; or when side plate is filed back to rear attaching rivet.
10. Service bar after each use.
  - Inspect groove depth and width; true and file rails; and inspect for bends.
  - Replace if rails are cracked, chipped, burned, or have a dip deeper than 1/16”.
  - Inspect sprocket tip for wear and looseness. Lubricate tip if grease type.
11. Test for performance. See B. Tests.
12. Remove all fuel from fuel tank. Run engine until carburetor is completely dry of fuel (use choke).

## Fire Equipment Storage and Refurbishing Standards

---

Continued --

ITEM: **CHAIN SAW**, 20" – 24" bar

NFES #000159

13. Prepare unit for storage (see F. Repackaging.)

- ✓ NOTE: If this equipment is taken to a "factory authorized" repair facility for refurbishment; ensure that they receive a copy of this refurbishment standard. The repair facility must; satisfy both, the requirements as set by the manufacturer specification and to the agreement made with the local agency.

### **D. Retesting Criteria**

1. Retest if date last tested (DLT) is exceeded or starter seal is broken.
2. Ensure C. Refurbishing Procedures is completed.

### **E. Cleaning Procedures**

1. Remove dirt, oil and grease, using detergent or degreaser as necessary (use pressure washer to remove heavy soil).
2. Use pressure washer, only if; you will start and run the saw the same day. Dry saw after washing.

### **F. Repackaging**

1. Use nylon "zip-tie" to tie off (seal) starter rope to handle bar, to later determine if equipment has been used.
2. Attach certification tag; that indicates date last tested (DLT), property #, and name of individual certifying performance.
3. Ensure that all identification (property #, serial #, owner ID) is affixed and legible.
4. Install chain cover on bar for safety.

### **G. Storage and Shelf Life Checks**

- ✓ Recommendation: Use a fuel stabilizer in fuel during testing to help ensure proper operation of engine at post storage start up.

Ensure date last tested (DLT) does not exceed 12 months.

### **H. References**

[www.stihlusa.com](http://www.stihlusa.com)  
[www.husqvarna.com](http://www.husqvarna.com),

---

## Fire Equipment Storage and Refurbishing Standards

---

ITEM: **CHAPS**, protective, summer weight

NFES #000044, #000045, #000078, #000150

### **A. Initial Inspection/Disposal Criteria**

✓ **Chaps should be removed from service if not labeled with specification USFS 6170-4F or are not certified to NFPA 1977-05. See Cache Memo 09-4 in H. References.**

✓ **CHAPS REMOVED FROM SERVICE MUST BE DESTROYED OR MADE UNSERVICABLE**

1. Fabric and webbing: if the item cannot be repaired economically, dispose of item.
  - a. Inspect for any holes, cuts, tears, or burns. If the item cannot be repaired economically, dispose of item.
  - b. Inspect for any area of abrasion that has weakened fabric beyond repair, if so dispose of item.
  - c. Inspect for any webbing that is cut, burned, or abraded beyond economical repair, if so dispose of item.
  - d. Inspect each leg, if either leg has more than five patches, dispose of item.
  - e. Dispose of item if the first layer of yellow Kevlar has a cut that is more than 1 inch long.
  - f. Dispose of item if improper repairs have been made, such as patch jobs that stitched through the Kevlar.
  - g. Dispose of item if wood chips and sawdust are evident inside the layers at the bottom of the chaps.
2. Hardware.

Inspect all molded nylon hardware for dirt, cracks, breaks, and proper function.  
See B. Tests.

### **B. Tests**

Test hardware by fastening and unfastening. The hardware should function easily with little force being applied and no difficulty in the release.

### **C. Refurbishing Procedures**

1. Clean chaps before repairing.
2. Repair burn holes and cuts.
  - a. Use Seam Grip® to repair holes or cuts in the nylon shell.
  - b. To repair holes shorter than ½ inch, apply a dot of Seam Grip® over the hole and allow the Seam Grip® to dry.
  - c. To repair holes and tears longer than ½ inch--
    - Cut a piece of paper about twice the size of the damaged area.
    - Slip the paper inside the tear in the nylon shell so that the paper lies on top of the Kevlar pad.
    - Press the nylon shell onto the piece of paper and squeeze Seam Grip® onto the paper and onto the sides of the tear.
  - d. Allow chaps to dry for at least 12 hours before using
  - e. Replace burned, abraded, or cut nylon webbing with like items.
  - f. Replace broken or nonfunctioning hardware.

### **D. Retesting Criteria**

Retest all replaced hardware as specified in B. Tests.

## Fire Equipment Storage and Refurbishing Standards

---

Continued –

ITEM: **CHAPS**, protective, summer weight

NFES #000044, #000045, #000078, #000150

### **E. Cleaning Procedures**

See Appendix A--Cleaning Instructions.

1. Allow any mud or loose dirt to dry and then remove using a stiff-bristle brush. If stains remain, wash as recommended below.
2. Remove light oil and dirt stains by brushing with a Citrosqueeze® solution, brush with a bristle brush, rinse thoroughly and hang to dry.
3. For heavier oil or grease soak in a Citrosqueeze® solution for at least 4 hours, brush with a bristle brush, rinse thoroughly and hang to dry

- ✓ **DO NOT MACHINE WASH OR DRY.**
- ✓ **DO NOT USE BLEACH TO CLEAN FABRIC.**
- ✓ **DO NOT PRESSURE WASH**

### **F. Repackaging**

STANDARD PACK is 10 per carton.

Pack in carton NFES #002007 (NSN 8115-00-292-0123).

### **G. Storage and Shelf Life Checks -- none**

### **H. Reference**

NFES Cache Memo No. 09-4

[http://www.nifc.gov/nicc/logistics/cachememo/CM09-4\\_Chainsaw\\_Chaps.pdf](http://www.nifc.gov/nicc/logistics/cachememo/CM09-4_Chainsaw_Chaps.pdf)

*Inspecting, Cleaning, Repairing, and Retiring USDA Forest Service Chain Saw Chaps*, June 2004, USDA FS MTDC 0451-2342P-MTDC.

[Inspection and repairing your Chainsaw Chaps, MTDC Publication 8267 2505.](#)

[CITROSQUEEZE®](#)

[Seam Grip® Seam Sealer & Outdoor Repair](#)



## Fire Equipment Storage and Refurbishing Standards

---

ITEM: **CLAMP**, hose, shut-off, 1" – 1½" hoses

NFES #000046

**A. Initial Inspection/Disposal Criteria**

1. Inspect for obvious/damage.
2. Inspect metal components for cracks or deformation, if any dispose of.
3. Inspect metal components for burn marks, if any dispose of.
4. Inspect all pins for excessive wear (very loose fittings). Replace the pins or dispose of.

**B. Tests -- none**

**C. Refurbishing Procedures**

Replace worn or broken pins.

**D. Retesting Criteria -- none**

**E. Cleaning Procedures**

Clean with a parts washer, high pressure washer, or with a mild detergent and scrub with a brush or scouring pad.

**F. Repackaging -- none**

**G. Storage and Shelf Life Checks -- none**

**H. Recycle as local cache options are available.**

**I. References.**

Water Handling Equipment Guide, NWCG PMS 447-1

<http://www.nwcg.gov/pms/pubs/WHEG03.pdf>

NFES Cache Memo No. 08-3 <http://www.nifc.gov/nicc/logistics/cachememo/cm08-3.pdf>

## Fire Equipment Storage and Refurbishing Standards

---

ITEM: **CONTAINER**, 1 liter, fuel, aluminum, red finish

NFES #001535

**A. Initial Inspection/Disposal Criteria**

1. Inspect for fuel in bottle and dispose of fuel properly.
2. Inspect outside of bottle for excessive dents, cracks, or evidence of fuel leakage, dispose of bottle if any are present.
3. Inspect inside of bottle for any foreign matter that cannot be removed. Dispose of bottle if this has occurred.
4. Inspect cap and bottle for any thread damage. Replace cap if necessary.
5. Inspect O-ring for damage or wear, replace if necessary.
6. Inspect for fill to here line, without it dispose of bottle.
7. Fuel bottles shall be of one-piece construction.

✓ Fuel containers that have threaded inserts crimped into the top shall be disposed of.

**B. Tests**

1. Visually inspect.
2. Fill with water and put cap on, invert to see if it leaks.

**C. Refurbishing Procedures**

1. Wash bottle inside and out with mild detergent or power wash.
2. Rinse thoroughly.
3. Replace O-ring if necessary.
4. Turn upside down with cap off and let air dry.

**D. Retesting Criteria -- none**

**E. Cleaning Procedures**

See C. Refurbishing Procedures.

**F. Repackaging**

Local cache option.

**G. Storage and Shelf Life Checks -- none**

**H. Recycle as local cache options are available.**

**I. Reference**

NFES Cache Memorandum No. 10-3

[http://www.nifc.gov/nicc/logistics/cachememo/CM10-3\\_Non\\_Compliant\\_Fuel\\_Bottles.pdf](http://www.nifc.gov/nicc/logistics/cachememo/CM10-3_Non_Compliant_Fuel_Bottles.pdf)

<http://safenet.nifc.gov/notice.nsf>

## Fire Equipment Storage and Refurbishing Standards

---

ITEM: **CONTAINER**, fuel/oil, 2 compartment, with CARB<sup>1</sup> compliant nozzles

NFES #000741

### A. Initial Inspection/Disposal Criteria

1. Inspect for fuel in container. If any, dispose of fuel properly.
  2. Inspect for leaks or separation along seams. Dispose of container if any are present.
  3. Inspect inside of container for any foreign matter that cannot be removed or identified. Dispose of container if this has occurred.
  4. Inspect all threads, moving parts, locking mechanism, auto-shut valve or spring mechanism on both (2) nozzles for serviceability. If nozzle does not spring to closed position when not pouring, dispose of.
- ✓ Certain nozzles are supplied with a dust cap. The dust cap **does not** have to be present for the container to be “ready for issue”. The gasket located on the lip of the nozzle and the nozzle’s auto-shut valve actually seals the container.

### B. Tests

1. Visually inspect.
2. Dispose of unserviceable containers, including those with unidentifiable contents.

### C. Refurbishing Procedures

1. Drain all existing fuel or oil.
2. Wash container inside and out with mild detergent with brush/scouring pad or power wash.
3. Rinse thoroughly.
4. Use rag and air hose to dry the container interior.
5. Turn upside down with lids off or open and let air dry.
6. Replace nozzle gaskets if stiff, damaged or missing.
7. Assemble both nozzles to unit to ensure nozzle-collar threads fit.
8. Replace nozzles as needed with nozzles that automatically spring to closed position (CARB compliant style).

### D. Retesting Criteria -- none

### E. Cleaning Procedures -- See C. Refurbishing Procedures.

### F. Repackaging -- Local cache option.

### G. Storage and Shelf Life Checks -- none

### H. References

- A source of CARB compliant nozzles: (there may be others) [www.baileysonline.com](http://www.baileysonline.com)
- California Environmental Protection Agency Air Resources Board (CARB) <http://www.arb.ca.gov/homepage.htm>
  - <sup>1</sup>CARB compliant nozzle has:
    - an autostop, self-venting nozzle that stops the flow of fuel when the target tank is full
    - a single opening for filling and pouring. No separate vents or openings.
    - a treated container body for very low permeation.
    - automatic closure. Nozzle automatically springs to the closure position when not pouring.

## Fire Equipment Storage and Refurbishing Standards

---

ITEM: **CORD**, extension, 50' or 100' AWG, 12/3 wire

NFES #000560, #001172

**A. Initial Inspection/Disposal Criteria**

1. Visually inspect for broken plugs, cracked, or damaged cord, if any dispose of.
2. Dispose of field modified cords if not economically feasible to repair.
3. Dispose or repair ends with grounding prong removed or damaged.
4. Dispose of any cord that is not UL approved with a 12/3 gauge minimum wire.

**B. Tests**

Plug into 110V source, and plug light into other end to ensure no connecting problems.

**C. Refurbishing Procedures**

Repair or replace as necessary.

**D. Retesting Criteria -- none**

**E. Cleaning Procedures**

Wipe down cord with damp cloth to remove foreign material.

**F. Repackaging**

1. Rollup cord (approximately 12—14" loop).
2. Tie off with wire ties or strappex banding (minimum of 1 per cord).
3. Tag cord with proper NFES number and nomenclature.
4. Repack in carton 18" X 15" X 15" (NSN 8115-00-290-3386).  
NFES #000560--3 each per carton.  
NFES #001172--2 each per carton.

**G. Storage and Shelf Life Checks -- none**

## Fire Equipment Storage and Refurbishing Standards

---

ITEM: **CORD**, light, 50', with multiple light sockets, AWG, 12/3 wire

NFES #000563

**A. Initial Inspection/Disposal Criteria**

1. Visually inspect for broken plugs, cracked or damaged cord, cracked or damaged sockets, bent or broken bulb guards.
2. If light bulbs are in place, plug into source and verify all sockets and bulbs are working.
3. Dispose of or repair if bulb guards are bent or missing.
4. Dispose of or repair if any bent plug.
5. Replace any cracked or broken light sockets.
6. Dispose of any broken, frayed, or burned cords.
7. Dispose of any cords that are not UL approved with a 12/3 gauge minimum wire.
8. Replace any missing or broken bulbs.

**B. Tests**

If not done during inspection above, plug cord into 110v source and test each socket by screwing in a bulb or testing with voltage tester at cache option.

**C. Refurbishing Procedures**

Repair or replace as described above.

**D. Retesting Criteria -- none**

**E. Cleaning Procedures**

1. Wipe down cord with a mild detergent solution to remove mud, dirt, and grease.
2. Clean guards with soapy water, brush, and scouring pad.
3. Do NOT soak.
4. Dry completely before use (due to possible electric shock).

**F. Repackaging**

Local cache option for coiling and repacking.

**G. Storage and Shelf Life Checks -- none**

ITEM: **COT**, folding, 12 oz cover, 3½' x 6½'

NFES #000053

**A. Initial Inspection/Disposal Criteria**

1. Visually inspect for tears in cover, soiled cover, missing parts, and loose nuts and bolts, replace.
2. Dispose of cot if structural damage to the frame is present.
3. Salvage usable parts when feasible.

**B. Tests**

1. Assemble to ensure completeness and all parts fitting properly.
2. Inspect for weakness or non-visual damage.

**C. Refurbishing Procedures**

1. If cover is torn or its seam is separated, replace the cover. See parts list C.4.a.
2. Replace damaged rail end tubing pieces. See parts list section C.4.b.
3. If plug for cot ends are missing replace them with the appropriate plug.  
See parts list C.4.c, d, and e.
4. Parts list for cot parts available from Department of Defense-S9I. See H. References for website info.
  - a. Cover, Nylon 7105-00-935-1845.
  - b. Rail End Tubing 7105-00-935-0424.
  - c. Plug (Dowel) 7105-00-935-0433.
  - d. Plug (Spacing) 7105-00-935-0344.
  - e. Plug (End) 7105-00-935-0435.
  - f. Strap 7105-00-113-0003.

**D. Retesting Criteria -- none**

**E. Cleaning Procedures**

1. Soiled cots can be power washed and left to dry.
2. Try to assemble cot completely before power washing.
3. If rail end tubing will not install properly wet cot to stretch nylon cover.
4. Disinfect cot per local cache option.

**F. Repackaging**

1. Refold and band.
2. Local cache option

**G. Storage and Shelf Life Checks -- none**

**H. Reference.**

To order parts: (this is a secure site, user name and password required.)

<https://emall6.prod.dodonline.net>

**I. Recycle components as local cache options are available.**

---

## Fire Equipment Storage and Refurbishing Standards

---

ITEM: **COUPLINGS**

NFES #000710, #000855, #000856, #000857,  
#000916, #007027, #007028, #007618, #007619

**A. Initial Inspection/Disposal Criteria**

1. Visual Inspects on male couplings.
2. Inspect for worn or damaged threads.
3. Inspect coupling to ensure it has not been smashed, bent, or cracked.
4. Ensure that rocker lugs are not stripped.
5. Visual Inspects on female couplings.
6. Inspect for worn or damaged threads.
7. Inspect coupling to ensure it has not been smashed, bent, or cracked.
8. Inspect for gaskets.
9. Ensure that swivel operates properly.
10. Ensure that rocker lugs are not stripped.

**B. Tests**

1. Male coupling-- attach to female coupling to ensure that threads operate smoothly.
2. Female coupling--ensure that threads operate smoothly.

**C. Refurbishing Procedures**

1. Male coupling--if threads are damaged, try to file with a triangular file.
2. Female coupling--replace gaskets if necessary.
3. Lubricate with a dry lubricant, i.e., graphite.

**D. Retesting Criteria**

Re-inspect male threads that have been repaired or “chased.”

**E. Cleaning Procedures**

1. Wash and clean of mud, dirt, and grease.
2. Clean in parts washer, high pressure wash or clean in sink with dishwashing detergent with a brush or scouring pad.
3. Rinse thoroughly and let dry.

**F. Repackaging**

Package 10 each in carton (cache option) and label accordingly.  
Package 60 each in carton (cache option) and label accordingly.

**G. Storage and Shelf Life Checks -- none**

**H. Recycle as local cache options are available.**

---

## Fire Equipment Storage and Refurbishing Standards

---

ITEM: **EXTINGUISHER**, fire, 20A:120BC, 20 lb (9.1L)

NFES #000307

**A. Initial Inspection/Disposal Criteria**

1. Visual inspection of use gauge.
  - a. Ensure the gauge arrow is registering in the “green”.
  - b. If gauge arrow is in the “red”, set aside for an authorized service representative.
2. Inspect for missing parts.
  - a. Safety pin.
  - b. hose
3. Verify tag for expiration date and signature of authorized service representative.  
If either of these is in question, set aside for authorized service representative.

**B. Tests**

Testing and filling performed by authorized service representatives only.

**C. Refurbishing Procedures**

Completed in B. Tests.

**D. Retesting Criteria -- none**

**E. Cleaning Procedures**

Wipe down entire unit with a damp rag and make sure hose is free of dirt or debris.

**F. Repackaging**

- a. Package 1 each in carton NFES #000385 to prevent accidental discharge of extinguisher.
- b. Label carton with:
  - extinguisher’s expiration date
  - NON-FLAMMABLE GAS 2 labels
  - Directional arrows “This Side Up”
  - NFES label

**G. Storage and Shelf Life Checks**

Yearly inspection by authorized service representative.



ITEM: **FENCE**, barricade, plastic, 4' X 50'

NFES #000608

**A. Initial Inspection/Disposal Criteria**

1. Inspect for damage, repair or dispose of.
2. Inspect for length, if less than 50' splice is required. (See C. Refurbishing Procedures.)
3. Inspect for dirt, grease, oil, or paint, clean or repair.

**B. Tests -- none**

**C. Refurbishing Procedures**

1. Replace damage barricade section by splicing.
2. Splice using small cable ties or small hog rings one top, one bottom, and one every 6 inches to ensure splice security; only one splice of same type and pattern for each barricade fence.

**D. Retesting Criteria -- None**

**E. Cleaning Procedures**

Clean by sweeping or with high-pressure wash; or clean with mild detergent using a brush or scouring pad.

**F. Repackaging**

Re-roll and secure.

**G. Storage and Shelf Life Checks -- none**

## Fire Equipment Storage and Refurbishing Standards

---

ITEM: **FLIGHT SUIT**

NFES #000501, #000507, #000508, #000509, #000514,  
#000517, #000518, #000519, #000521, #000525, #000527, #000539,  
#000545, #000546, #000547, #000548, #000567, #000572, #000574, #000576

**A. Initial Inspection/Disposal Criteria**

1. Inspect for holes, cuts, tears, burns, or torn seams, if any dispose of.
2. Inspect hook and pile fastener missing or that does not provide adequate closure, repair or dispose of.
3. Inspect zipper broken or missing a slider, dispose of.

**B. Tests**

1. Open and close the hook and pile fasteners to ensure they provide an adequate and secure closure.
2. Open and close zipper to ensure smooth operation and a secure closure.

**C. Refurbishing Procedures -- none**

**D. Retesting Criteria -- none**

**E. Cleaning Procedures**

See Appendix A--Cleaning Instructions.

**F. Repackaging**

Local cache option.

**G. Storage and Shelf Life Checks -- none**

## Fire Equipment Storage and Refurbishing Standards

---

ITEM: **FLY**, plastic, tent, 16' X 24' with 10 guy ropes

NFES #000070

**A. Initial Inspection/Disposal Criteria**

1. Dispose of nonstandard item.
2. Inspect for rips and tears on main sheet.
3. Inspect borders for seam damage and loose grommets. If not economical to repair dispose of.
4. Inspect for petroleum or other stains on main sheet.
5. Inspect for mold or mildew.

**B. Tests -- none**

**C. Refurbishing Procedures**

1. Completely unfold tent fly on clean, dry floor or work area so that any defects (tears, burns, mildew, etc.) will be visible.
2. Sweep off entire fly with stiff-bristle broom.
3. Repair any minor rips, tears, or any other defects at this time (if possible)
4. Replace missing grommets with 5/8" brass grommets.
5. Repair missing or damaged guy ropes with 25' X 1/4" manila rope with sliders (NFES# 001043).
6. Fly should have 10 each guy ropes.

**D. Retest Criteria -- none**

**E. Cleaning Procedures**

See Appendix A--Cleaning Instructions

**F. Repackaging**

1. Utilize flat, clean surface greater than 20' X 20'.
2. Fold lengthwise once, fold lengthwise again, and sweep after each fold until fly is in a neat, tight package approximately 16" X 24".
3. Secure fly with 1/4" manila or similar rope.
4. Use carton NFES #002006 (NSN 8115-00-139-0722) or band.
5. Tag finished product with proper NFES # and nomenclature.

**G. Storage and Shelf Life Checks -- none**

ITEM: **FLY**, sunscreen, 20' x 20', with 10 guy ropes

NFES #006131

**A. Initial Inspection/Disposal Criteria**

1. Nonstandard item, if smaller than 20' x 20' dispose of.
2. Inspect for rips and tears, dispose of if uneconomical to repair.
3. Inspect borders for seam damage and loose grommets.
4. Inspect for excessive petroleum products, if so dispose of.
5. Inspect for mildew.

**B. Tests -- none**

**C. Refurbishing Procedures**

1. Completely unfold fly on clean, dry floor or work area so that any defects (tears, burns, mildew, etc.) will be visible.
2. Repair any rips, tears, or any other defects.
3. Replace missing or damaged guy ropes with NFES #001043, 25' X ¼" manila rope w/tension dowels (10 each).
4. Replace missing grommets with 5/8" brass grommets.

**D. Retest Criteria -- none**

**E. Cleaning Procedures**

1. Sweep off entire fly with stiff bristle broom.
2. Power wash with a mild detergent, if necessary, and air dry.

**F. Repackaging**

1. Utilize flat, clean surface greater than 20' X 20'.
2. Fold lengthwise once, fold lengthwise again and sweep each after each fold until fly is in neat, tight bundle.
3. Secure fly with strapping, ¼" manila or similar rope. Use carton NFES #002006.
4. Label carton with proper NFES number and item description.

**G. Storage and Shelf Life Checks -- none**

## Fire Equipment Storage and Refurbishing Standards

---

ITEM: **FLY**, tent, type II, 9' x 10'

NFES #001521

**A. Initial Inspection/Disposal Criteria**

1. Nonstandard item, dispose of.
2. Rips and tears, if any other than pinholes dispose of.
3. Inspect borders for seam damage and missing or loose grommets, if any dispose of.

**B. Tests -- none**

**C. Refurbishing Procedures**

1. Unfold and look for defects.
2. Sweep or brush off with stiff broom or brush.

**D. Retesting Criteria -- none**

**E. Cleaning Procedures**

See Appendix A--Cleaning Instructions.

**F. Repackaging**

Package 20 each in carton (cache option) and label accordingly.

**G. Storage and Shelf Life Checks -- none**

ITEM: **FOAM UNIT**, round pump

NFES #007056

**A. Initial Inspection/Disposal Criteria**

Check kit for damage and/or missing components.

**B. Tests**

Inductor meter should move freely.

**C. Refurbishing Procedures**

1. Clean all parts as necessary--see E. Cleaning Procedures.
2. Wash out container.
3. Inspect inductor meter. See B. Tests.
4. Dry thoroughly, and repack kit--see F. Repackaging.

**D. Retesting**

Ensure C. Refurbishing Procedures is completed.

**E. Cleaning Procedures**

Run clean warm water through all parts until; there is no foam visible.

**F. Repackaging**

1. Ensure all parts are dry.
2. Inventory kit to ensure kit is complete.
3. Seal the kit, to later determine if equipment has been used.

**G. Storage and shelf life checks -- none.**

**H. References -- none.**

---

## Fire Equipment Storage and Refurbishing Standards

---

ITEM: **FOOD**, meals ready to eat (MRE'S)

NFES #001842

**A. Initial Inspection/Disposal Criteria**

1. Receipt inspection: Verify shipping carton for marking of MRE meals. The carton must show the following data:
  - N (National Stock Number)
  - Item Nomenclature
  - Wt. \_\_\_\_\_ Cu \_\_\_\_\_
  - Contract No. \_\_\_\_\_ Lot No. \_\_\_\_\_
  - Name and Address of Ration Assembly Contractor
  - Date packed
  - ITD Inspection test date
  - Fresh – Check Indicator
2. Expiration of MRE meals will be based on a US Army food service inspector's evaluation.
3. The Fresh-check Indicator may be used for field inspections.
4. MRE meals will be disposed of if the meal storage pouch is open.
  - a. That meal will be removed from its container and rendered unusable and placed in a wet-garbage container.
  - b. The water activated heater, for heating the MRE entree will be removed from the meal and placed in a metal pail with water to deactivate. They may then be disposed of in your local landfill.

**B. Tests -- none**

Requires food service inspection.

**C. Refurbishing Procedures -- none**

Dispose of all loose, partial, or open MRE meals, and all unmarked MRE meals, and MRE meals in unmarked shipping containers, i.e., not in original shipping containers.

**D. Retesting Criteria**

1. Inspect container for proper marking.
2. Look for-- container damage, insect or rodent damage, and product leakage and foul odor. If damage found follow A. Initial Inspection/Disposal Criteria.
3. Mark case/pallet with next inspection test date if no damage found.

**E. Cleaning Procedures**

1. Dust case.
2. Look for damage as noted in D. Retesting Criteria.

**F. Repackaging**

Label appropriately and store accordingly.

Continued –

ITEM: **FOOD**, meals ready to eat (MRE'S

NFES #001842

**G. Storage and Shelf Life Checks**

Official Answers

Officially, how long MREs last depends on how long they are stored and at what temperatures they are stored. At the least, they'll last 1 month at 120 degrees F. Or they could last 130+ months at 60 degrees F. Here's the time/temp chart typically used:

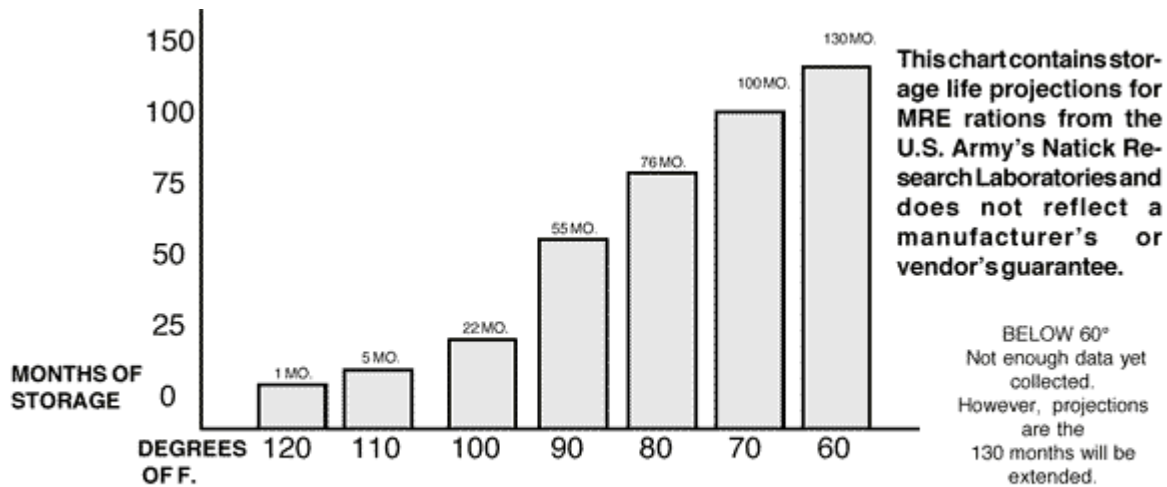

NOTE: Time and temperature have a cumulative effect. For example, storage at 100° for 11 months moved to 70° would lose one half of the 70° storage.

**AVOID FLUCTUATING TEMPERATURES IN AND OUT OF FREEZING LEVEL**

Since about 1997, MRE cases have also included something called a TTI (time and temperature indicator) on the outside of the box to assist inspectors in determining if MREs are still good. There are two parts to the TTI - an outer dark circle and an inner light circle. As long as the inner circle is still lighter than the outside circle, the MREs are supposed to be good. For the official info on the TTIs visit [http://www.natick.army.mil/soldier/media/fact/food/Time-Temperature\\_Indicator.htm](http://www.natick.army.mil/soldier/media/fact/food/Time-Temperature_Indicator.htm).

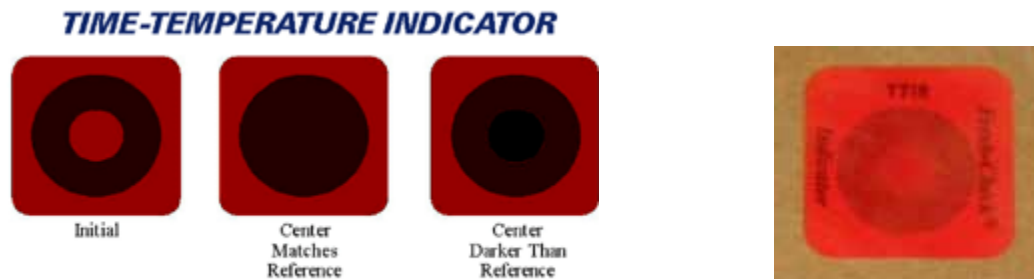

Implementation with MRE XVII

**H. Reference**

<http://www.dscp.dla.mil> go to search--type MRE  
[www.mreinfo.com](http://www.mreinfo.com).



---

## Fire Equipment Storage and Refurbishing Standards

---

ITEM: **GENERATOR**, gasoline engine, 3 to 6 KW w/ground rod

NFES #000709

### A. Initial Inspection/Disposal Criteria

- ✓ NOTE: Follow the manufacturer's safety precautions as listed in the owner's manual prior to operation of this item.
- ✓ If unit is not economically repairable it should be disposed of using local agency policy.
  1. Visually inspect for evidence of use (dust, oil, starter seal broken), damage or missing parts.
  2. Return to stock if: there is no sign of use or damage and date last tested (DLT) does not exceed 12 months.
  3. Refurbish as necessary if unit has been used, damaged, or shelf life is exceeded.

### B. Tests

- ✓ NOTE: Refer to the owners' manual for operations and specifications information specific to generator model.
  1. Check condition of fuel and engine oil; ensure fuel is fresh and oil level is sufficient for running tests. See G. Storage and Shelf Life Checks.
  2. Make certain there are no fuel leaks and the generator is properly grounded prior to starting engine.
  3. Test function of rewind starter, ensure proper engagement of engine and recoil functionality.
  4. Check for damage or fraying of pull cord; repair or replace as necessary.
  5. Engine should; start easily, run smoothly, have no leaks, and provide sufficient power to generator.
  6. Test function of stop switch, electrical panel and output of generator.
  7. Ensure proper operation of all circuit protection: Ground Fault Circuit Interrupter (GFI), circuit breakers and power outlets.
  8. Measure power outlet of generator, ensuring proper performance as established by the manufacturer.
- ✓ Should any function fail a test, use the manufacturers' repair manual and troubleshooting guide to correct the problem.

### C. Refurbishing procedures

1. Clean unit as necessary (see E. Cleaning Procedures.)
2. Check condition of engine oil, spark plug and air filter; clean or replace as necessary.
3. Check for loose and/or missing parts or mounting hardware; tighten or replace where needed.
4. Inspect exhaust system; make sure there are no cracks and or leaks.
5. Clean spark arrestor screen of excess carbon build up, replace if screen is damaged.
6. Inspect fuel tank, filler cap, fuel line and fuel filter; clean, repair and/or replace as needed.
7. Ensure that the recoil starter operates properly and that the rope is not frayed or damaged.
8. Ensure proper condition of battery (if equipped)
9. Test for performance (see B. Tests.) Should any function fail a test, refer to the manufacturers' repair manual and troubleshooting guide to correct the problem.
10. Remove all gasoline from fuel tank and fuel line. Run engine until carburetor is completely dry of fuel (use choke).
11. Prepare unit for storage (see F. Repackaging.)

## Fire Equipment Storage and Refurbishing Standards

---

Continued—

ITEM: **GENERATOR**, gasoline engine, 3 to 6 KW w/ground rod

NFES #000709

- ✓ NOTE: If this equipment is taken to a “factory authorized” repair facility for refurbishment; ensure that they receive a copy of this refurbishment standard. The repair facility must satisfy both--the requirements as set by the manufacturer specification and the agreement made with the local agency.

**D. Retesting Criteria**

1. Retest if date last tested (DLT) is exceeded or starter seal is broken.
2. Ensure section C. is completed.

**E. Cleaning Procedures**

Remove dirt and oil, using detergent or degreaser as necessary.

**F. Repackaging**

1. Use nylon “zip-tie” to tie off (seal) starter rope to the frame, to later determine if equipment has been used.
2. Attach certification tag; that indicates date last tested (DLT), property #, and name of individual certifying performance.
3. Ensure that NFES #000551 ground rod is complete and attached to the frame.
4. Ensure that all identification (property #, serial #, owner ID) is affixed and legible.

**G. Storage and Shelf Life Checks**

- ✓ Recommendation: Use a fuel stabilizer in fuel during testing to help ensure proper operation of engine at post storage start up.

Ensure date last tested (DLT) does not exceed 12 months.

**H. References**

[www.hondapowerequipment.com](http://www.hondapowerequipment.com)

[www.tsurumipump.com](http://www.tsurumipump.com)

[www.cumminsonan.com](http://www.cumminsonan.com)

[www.homelite.com](http://www.homelite.com)

ITEM: **HARNESS**, chest, fire shelter

NFES #000294

**A. Initial Inspection/Disposal Criteria**

1. Webbing.
  - a. Inspect webbing for cuts, tears, frayed, or burned, if any dispose of.
  - b. Inspect for any area of abrasion that has weakened the webbing beyond repair, dispose of.
2. Hardware  
Inspect all plastic hardware for cracks, breaks, and proper function. See B. Tests.

**B. Tests**

Test hardware by fastening and unfastening. The hardware should function easily with little force and difficulty in opening and closing.

**C. Refurbishing Procedures**

1. Repair holes, cuts, tears, and/or burns, if economical repair.
2. Replace damaged hardware.

**D. Retesting Criteria -- none**

**E. Cleaning Procedures**

See Appendix A--Cleaning Instructions.

**F. Repackaging**

Local cache option.

**G. Storage and Shelf Life Checks -- none**

ITEM: **HEADLAMP**, firefighters (advanced)

NFES #000667

**A. Initial Inspection/Disposal Criteria**

1. Inspect lamp head.
  - a. Lamp head should have two bulbs, one in place for use, and one inside the housing as a spare.
  - b. The computer chip inside the housing should be intact and firmly in place.
  - c. Lens/reflector should be clear, unscratched, and turn on the housing with resistance--if not dispose of.
  - d. The housing should be free of cracks and the switch boot free of cracks or tears.
  - e. The strap lugs should be intact--if not dispose of.
  - f. O-ring should be free of cracks and pliable--if not dispose of and replace.
  - g. The wire should be tight and have no cracks
  - h. The connector should be round and clean.
2. Inspect battery pack.
  - a. Housing should free of cracks, both cap lugs and strap lugs should be present and intact.
  - b. The cap should be free of cracks, the wire tight and without defect and the O-ring intact. The cap should fit snugly on the battery housing and lock in place. The connector plate inside the cap should be centered and free of corrosion.
  - c. The battery frame should be intact and firmly hold 5 AA batteries.
  - d. The electrical connectors should mate with the connectors in the cap.
3. Inspect helmet strap.

The helmet strap should be without tears, pliable, and hold the headlamp components.

**B. Tests**

1. Insert 5 new AA batteries into the battery frame all pointing towards the top.
2. Insert battery frame into the battery housing.
3. Tighten the cap; attach the lamp head, the light should go on.
4. Press and release the lamp button, the light should either brighten or dim.
5. Press and hold the lamp button, the light should go off.
6. Remove batteries.

**C. Refurbishing Procedures**

Replace components until the lamp works properly.

**D. Retesting Criteria**

Retest as specified in B. Tests.

**E. Cleaning Procedures**

Clean headlamp with clean water.

**F. Repackaging**

Store 20 headlamps per carton.

**G. Storage and Shelf Life Checks**

Headlamps should be stored without batteries.

Continued ---

ITEM: **HEADLAMP**, firefighters (advanced)

NFES #000667

**H. Reference**

Replacement parts can be obtained from:

Easter Seals Greater Hartford Rehabilitation Center, Inc.  
100 Deerfield Road  
Windsor, CT 06095  
Phone: 860-714-9500

## Fire Equipment Storage and Refurbishing Standards

---

ITEM: **HEADLAMP**, single cell, cordless (*obsolete, replaced by NFES #000667*) NFES #000713

**A. Initial Inspection/Disposal Criteria**

Inspect for broken wires, rust or corrosion on any metal part, and cracks in the case or lens cover. If detected dispose.

**B. Tests**

1. Test unit with new batteries.
2. Test both bulbs; if defective, replace with stock on hand otherwise dispose of.
3. Test elasticity of headband; if defective, replace with stock on hand otherwise dispose of.
4. If cracks in insulation are less than 3 inches from termination point dispose of.
5. Check O-rings are present and pliable, replace if necessary.

**C. Refurbishing Procedures**

1. Test and clean entire unit.
2. Install new bulbs, headband and O-ring if required.
3. Limit refurbishing and replacement of parts to stock on hand. Item is obsolete-- do not purchase parts to extend durability. Salvage parts, then dispose of.

**D. Retesting Criteria -- none**

**E. Cleaning Procedures**

Wipe entire unit clean to include lamp housing, battery cam, and both sides of lens.

**F. Repackaging**

Package 24 individual headlamps in 20" X 20" X 20" carton (NSN 8115-00-428-4158).

✓ **CAUTION—Do not repack units with batteries.**

**G. Storage and Shelf Life Checks -- none**

## Fire Equipment Storage and Refurbishing Standards

---

ITEM: **HEATER**, propane, 20# tank mounted  
**HEATER**, propane, outdoor, 360° radiant heat

NFES #006139  
NFES #006187

### A. Initial Inspection/Disposal Criteria

1. Visual inspection indicating use or missing parts (guards, knobs, etc.), or structural damage preventing repair—if so, salvage usable parts, then dispose of.
3. Inspect for torn or cut heater element, if so dispose of heater.
4. Inspect for damaged or cracked hose/hose connections, if so replace.
5. Inspect for damage to regulators, if so dispose of.
6. Check for loose fittings.

### B. Tests

1. Prior to testing use an air hose to blow unit off of any dust, dirt or debris.
2. Inspect hoses for cracks, inspecting for breaks by flexing, if so dispose of.
3. Inspect hose or valve for foreign material that might cause a blocked line, if so dispose of.
4. Inspect O-rings on supply hose and replace if needed.
5. Inspect for out-of-round fittings by screwing regulator into tank POL fitting.
6. Mount or connect the heater to a LP-Gas supply cylinder.
7. Turn on gas supply to the heater and check all fittings and connections for gas leaks using mild soap and water solution. Should a gas leak occur, shut off the gas supply to the heater immediately and wait a minimum of five minutes before repairing the leak.

✓ **CAUTION: Do not inspect by using a match or any other type of flame.**

✓ **ALWAYS HAVE A FIRE EXTINGUISHER IN WORK AREA PRIOR TO LIGHTING ANY HEATER.**

When assured that there are no leaks, light heater/pilot. If heater/pilot does not ignite within 5 seconds, extinguish flame and shut off gas valve. Wait 5 minutes before retrying.

8. (#006139 heaters) Once pilot is lit, let run for 3-5 minutes, try on/off cycle 2 to 3 times.
9. (#006187 heaters) Once pilot is lit, turn heater on, let run for 3-5 minutes; try on/off cycle 2 to 3 times.
10. If heater fails, determine if economical to repair, send to a certified repair shop.
11. Inspect auto shut off valve is in working condition by tipping unit over (if applicable.)

### C. Refurbishing Procedures

1. Replace regulator if there is any damage to the regulator or threads do not properly seat.
2. Replace or straighten any damaged or bent parts.
3. Repair or replace auto shut off valve if not working properly (if applicable.)

**D. Retesting Criteria**--Follow procedures in B. Tests.

### E. Cleaning Procedures

1. Clean the outside of the heater using a damp cloth. DO NOT clean the heater by spraying water on it (MANUFACTURER'S RECOMMENDATION).
2. Clean the inside of the heater using compressed air.

### F. Repackaging

Repack in original carton if possible or pack to local cache requirements.

**G. Storage and Shelf Life Checks** -- none

**H. Reference** --[Mr. Heater - America's Most Popular Portable Heaters](#)

## Fire Equipment Storage and Refurbishing Standards

---

ITEM: **HELMET**, flight, SPH-5TPL  
**HELMET**, flight, SPH-5C

NFES #001214, #001215  
NFES #002314, #002315

**A. Initial Inspection/Disposal Criteria**

1. Visual inspection indicating use or missing parts (screws, visors, worn cords, etc.).
2. Structural damage (cracked shell, visor housing, booms, etc.).
3. Structural damage preventing repair and refurbishment (cracked helmet shell, salvage useable part and dispose of helmet shell).
4. Flight helmets must meet requirements in Instruction Memo No. 96-2006 (In reply refer to: 9400 (FA-100). SPH-4 Helmet should be converted to SPH-5 Helmets or disposed of).

**B. Tests**

All testing and refurbishment will be conducted by certified personnel.  
Agency flight helmet testing and refurbishment maybe preformed by the following:  
National Interagency Fire Center  
Ramp Services  
3833 S. Development Avenue  
Boise, ID 83705  
Phone: 208-387-5529  
Fax: 208-387-5785

**C. Refurbishing Procedures**

1. Test avionics.  
Earphones.  
Microphone.  
Cord assembly.  
Microphone cable assembly.
2. Clean flight helmet thoroughly.
3. Replace missing or damaged parts.
4. Replace thermoplastic liner (TPL) in SPH-5 TPL.  
Size Regular NFES #003063.  
Size XL- NFES #003064.  
Size Small NFES #003065. Contact address above for further information.

**D. Retesting Criteria**

Retest avionics if necessary.

**E. Cleaning Procedures**

Use general purpose cleaner. (Do not use bleach, paint remover, thinner, or acetone on flight helmet shell. It may cause damage).

**F. Repackaging**

Package 1 each in 12" X 12" X 12" carton (NSN 8115-00-079-8680).

**G. Storage and Shelf Life Checks -- none**

**H. References --** <http://amd.nbc.gov/safety/library/helmetguide.pdf>  
[http://amd.nbc.gov/safety/library/alerts/IA\\_Alert\\_0701.pdf](http://amd.nbc.gov/safety/library/alerts/IA_Alert_0701.pdf)



## Fire Equipment Storage and Refurbishing Standards

---

ITEM: **HELMET**, safety, plastic, w/chin strap

NFES #000109

### A. Initial Inspection/Disposal Criteria

- ✓ Follow NFES Cache Memo 11-01 and attachment

[http://www.nifc.gov/nicc/logistics/cachememo/CM2011-1\\_Hard\\_Hat.pdf](http://www.nifc.gov/nicc/logistics/cachememo/CM2011-1_Hard_Hat.pdf)

[http://www.nifc.gov/nicc/logistics/cachememo/CM2011-1\\_attachment.pdf](http://www.nifc.gov/nicc/logistics/cachememo/CM2011-1_attachment.pdf)

1. Inspect for cracks, chips in shell, scuff marks and discoloration, and if so dispose of.
2. Ensure that all attachment clips are present (chin strap, headlamp, liner, neck and face shroud).
3. Inspect for markings, drawings or labels, if any dispose of.
4. All certification labels (ANSI, etc.) must be present in helmet, if not dispose of.

### B. Tests

- ✓ Follow NFES Cache Memo 11-01 and attachment

[http://www.nifc.gov/nicc/logistics/cachememo/CM2011-1\\_Hard\\_Hat.pdf](http://www.nifc.gov/nicc/logistics/cachememo/CM2011-1_Hard_Hat.pdf)

[http://www.nifc.gov/nicc/logistics/cachememo/CM2011-1\\_attachment.pdf](http://www.nifc.gov/nicc/logistics/cachememo/CM2011-1_attachment.pdf)

### C. Refurbishing Procedures

1. Wash with soap and water, rinse, then air dry.
2. Replace with new liner and new chin strap.
  - Bullard helmet use liner NFES #002025 (<http://www.bullard.com>)
  - Mine Safety Appliances (MSA) helmets use liner NFES #007036 (<http://www.msanorthamerica.com>)
3. Attach front 2 suspension clips to helmet to ensure proper fit.
4. Add or replace reflective strips.
5. Add or replace Velcro strips
6. Velcro strips 1½” by 2¼” and placed at center at rear of helmet and 9½” around curvature of helmet on each side.
7. The adhesive used shall be approved by the manufacturer for use on the helmet.
8. Follow NFES Cache Memo 11-01 for “*Marking the Date of Issue on Hardhat*”.

### D. Retesting Criteria -- none

### E. Cleaning Procedures

Wash entire shell with soap and water.

### F. Repackaging

Place helmet in a plastic bag and pack in carton NFES #002007 (NSN 8115-00-292-0123).  
STANDARD PACK 20 helmets per carton.

### G. Storage and Shelf Life Checks -- none

### H. References

Velcro available from: Textrol Systems Inc., 435 Meadow Lane, Carlstadt, NJ 07072

Phone: 800-624-8746

Part #193973 (Part B-male)

### I. Recycle as local cache options are available.

ITEM: **HOSE**, garden, synthetic, 3/4" NH x 50'

NFES #001016

**A. Initial Inspection/Disposal Criteria**

1. Visually inspect for burns, cuts, damaged fittings, if any dispose of.
2. Recycle brass fittings from disposed hose.
3. Inspect gasket for cracks, if any replace.

**B. Tests**

1. Start pump.
2. Test hose at bib pressure, which should be at least 150 PSI.
  - a. Check bib pressure with pressure gauge.
  - b. Gauge can be purchased at any local hardware store.
3. Hold for 2 minutes and inspect hose for leaks.
4. Shut down pump.
5. Drain excess water from hose.

**C. Refurbishing Procedures -- none**

**D. Retesting Criteria -- none**

**E. Cleaning Procedures**

1. Remove excess dirt from hose.
2. Wash hose with clean water or clean water with mild detergent or high pressure wash.
3. If detergent is used, rinse with clean water.
4. Allow hose to dry thoroughly.

**F. Repackaging**

1. Roll hose in single-roll configuration, male fitting in center of roll.
2. Secure role with band.
3. Package 20 lengths in a carton 16" X 12" X 10" and label accordingly.

**G. Storage and Shelf Life Checks -- none**

---

## Fire Equipment Storage and Refurbishing Standards

---

ITEM: **HOSE**, lined

NFES #000932, #000933, #000966, #000967, #001238, #001239

**A. Initial Inspection/Disposal Criteria**

1. Segregate by NFES number.
2. Inspect for obvious burns, cuts, or damaged couplings, if so dispose of.
3. Inspect for worn, defective or missing gaskets, if so replace.

**B. Tests**

1. For detailed information refer to H.
2. Replace gasket if necessary.
3. Connect female end of hose to pump or manifold
  - a. confirm not out of round and no damaged threads
  - b. All 1½” hose should be NH threads. All 1” hose should be NPSH threads
4. Pressure Test
  - a. Start pump.
  - b. Make sure nozzles are open. Let all air escape from hose. Shut nozzles.
  - c. Time for 3 minutes after reaching 300 PSI.
  - d. Walk the length of the hose inspecting for the following which indicate a need for repair or disposal: burns, cuts, or leaks between hose and couplings, and at swivel portion of female coupling.
  - e. Test for 3 minutes, turn off pump water.
5. Female and male couplings.
  - a. Inspect for leaks where hose goes into coupling.
  - b. Inspect for crooked coupling (easier to see when hose is charged).
6. Remove hose.
7. Stretch out good hose to drain.

**C. Refurbishing Procedures**

1. Refurbished hose shall result in lengths that are a minimum of 90 percent of original length.
2. Good couplings shall be salvaged from disposed hose.
3. Re-coupling procedures.
  - a. Remove old expansion ring and coupling from hose.
  - b. Remove unserviceable portion of hose, squaring end to be re-coupled.
  - c. Utilize expander machine to insert new expander and coupling. Follow specific machine operating instructions.
  - d. Refurbished hose shall result in hoses that are 90 to 100 foot in length.

**D. Retesting Criteria**

1. None required unless re-coupling has occurred.
2. Following re-coupling, follow test procedures as outlined in section B.3.

**E. Cleaning procedures**

1. Clean excess dirt from hose.
2. Run hose through hose washer using other clean water or clean water with a mild detergent.
3. If detergent is used, rinse with clean water.
4. Allow hose to dry thoroughly before rolling.

## Fire Equipment Storage and Refurbishing Standards

---

Continued –

ITEM: **HOSE**, lined

NFES #000932, #000933, #000966, #000967, #001238, #001239

**F. Repackaging**

1. Roll in a single roll configuration-male coupling in center of roll.
2. Secure roll (plastic band, string)
3. Local cache option for storage.
4. Roll, secure, and place on pallet.
  - Cache option quantity per pallet 1” X 100’ length/pallet.
5. Roll, secure, and place on pallet.
  - Cache option quantity per pallet 1½” X 100’ length/pallet.
6. Roll, secure, and package 2 lengths in carton (to be determined).
  - Cache option quantity per pallet.

**G. Storage and Shelf Life Checks -- none**

**H. Reference**

Water Handling Equipment Guide, NWCG PMS 447-1

<http://www.nwcg.gov/pms/pubs/WHEG03.pdf>

## Fire Equipment Storage and Refurbishing Standards

---

ITEM: **HOSE**, synthetic weeping

NFES #001873, #000334

### A. Initial Inspection/Disposal Criteria

1. Segregate by NFES number.
2. Inspect for obvious burns, cuts, and damaged couplings, worn or defective gaskets.

### B. Tests

✓ See current edition of the [\*Water Handling Equipment Guide\*](#), NWCG PMS 447-1 for hose testing procedures.

1. Replace gasket if necessary.
2. Connect female end of hose to pump or manifold
  - a. confirm not out of round and no damaged threads.
  - b. All 1½” hose should be NH threads.
  - c. All 1” hose should be NPSH threads.
3. For linen hose, begin pressure test with a 5-minute wet soak at 50 PSI prior to applying full test pressure.
4. When hose is under pressure, walk the length of hose inspecting for the following which will indicate a need for repair or disposal: leaks between hose and couplings and at swivel portion of female coupling.
5. Pressure test.
  - a. Start pump.
  - b. Time for 3 minutes after reaching 300 PSI.
  - c. Walk the length of the hose two or three times looking for burns or cuts.
  - d. After 3 minutes turn off pump water.
6. Female and male couplings.
  - a. Inspect for leaks where hose goes into coupling.
  - b. Inspect for crooked coupling (easier to see when hose is charged).
  - c. Remove hose.
  - d. Stretch out good hose to drain.

✓ NOTE: Items 6.c and 6.e require special attention with synthetic hose.

### C. Refurbishing Procedures

1. Refurbished hose shall result in lengths that are a minimum of 90 percent of original length.
2. Good couplings shall be salvaged from disposed hose.
3. Re-coupling procedures:
  - a. Remove old expansion ring and coupling from hose.
  - b. Remove unserviceable portion of hose, squaring end to be re-coupled.
  - c. Utilize expander machine to insert new expander and coupling.  
Follow specific machine operation instructions.

### D. Retesting Criteria

1. None required unless re-coupling has occurred.
2. Following re-coupling, follow test procedures as outlined in B.6.

### E. Cleaning procedures

1. Clean excess dirt from hose.
2. Run hose through hose washer using other clean water or clean water with a mild detergent.
3. If detergent is used, rinse with clean water.

Continued –

ITEM: **HOSE**, synthetic weeping

NFES #001873, #000334

4. Dry linen hose immediately after testing and washing to avoid mildew. Allow synthetic hose to dry thoroughly before rolling.
5. A 100-foot hose is hung from the middle and left to drain for 4 hours.
  - a. After 4 hours, double hose again, with couplings off the ground.

**F. Repackaging**

1. Roll in a single roll configuration-male coupling in center of roll.
2. Secure roll (rubber or plastic band, string).
3. Local cache option for storage.

**G. Storage and Shelf Life Checks**

1. Linen hose should be inspected periodically for mildew or rot.
2. Linen hose should be retested after 3 years on the shelf, regardless of appearance.

**H. Reference**

Water Handling Equipment Guide, NWCG PMS 447-1

<http://www.nwcg.gov/pms/pubs/WHEG03.pdf>

## Fire Equipment Storage and Refurbishing Standards

---

ITEM: **HOSE**, suction

NFES #000115, #000652, #000914, #001808

**A. Initial Inspection/Disposal Criteria**

Visually inspect for cracks, cuts, damaged couplings, and gasket, if so dispose of.

**B. Tests**

✓ See current edition of the [Water Handling Equipment Guide](#), NWCG PMS 447-1 for complete annual testing procedures.

1. Service pressure test.
2. Start pump.
3. Test for 3 minutes at 50 PSI.
4. Inspect hose for leaks.
5. Shut down pump.
6. Drain hose completely.
7. Dry vacuum test.

**C. Refurbishing Procedures**

Replace gasket if necessary.

**D. Retesting Criteria -- none**

**E. Cleaning Procedures**

1. Remove excess dirt from hose.
2. Clean with damp rag.
3. Apply a rubber protectant to prevent drying and cracking.

**F. Repackaging**

1. No special repack requirements.
2. Protect male coupling threads.

**G. Storage and Shelf Life Checks -- none**

**H. Reference**

[Water Handling Equipment Guide](#), NWCG PMS 447-1  
<http://www.nwcg.gov/pms/pubs/WHEG03.pdf>

## Fire Equipment Storage and Refurbishing Standards

---

ITEM: **HOSE ROLLER**, electric

NFES #000633

**A. Initial Inspection/Disposal Criteria**

1. Inspect for: missing parts, proper foot pedal switch operation, cracks in frame structure, roller pins in place, exterior motor damage; damaged or cut power cord.
  2. Verify that the protective guards are on any and all moving parts. (i.e., foot pedal shroud)
  3. Return to stock if there is no sign of use or damage.
- ✓ If unit is not economically repairable it should be disposed of using local agency policy.

**B. Tests**

Plug in to power source and test motor and moving parts.

**C. Refurbishing Procedures**

1. Blow dust and dirt out of electric motor.
2. If needed wash with high-pressure washer (cover electric motor).
3. Let dry.
4. Repair cracks in frame as needed.
5. Repair or replace power cord (if damaged).  
Ensure no exposed wire, grounding hazards or electrical shock risks.
6. Prepare unit for storage. See F. Repackaging.

**D. Retesting Criteria**

1. Retest after servicing motor and/or transfer case.  
Test roller under a load by means of rolling lengths of hose.
2. Plug in to power source and test motor and moving parts.

**E. Cleaning Procedures**

See C. Refurbishing Procedures.

**F. Repackaging**

1. Use nylon “zip-tie” to tie off (seal) power cord to frame, to later determine if equipment has been used.
2. Attach certification tag; that indicates date last tested (DLT), property #, and name of individual certifying performance.
3. Ensure that all identification (property #, serial #, owner ID) is affixed and legible.

**G. Storage and Shelf Life Checks -- none**



---

## Fire Equipment Storage and Refurbishing Standards

---

ITEM: **HOSE ROLLER**, gas

NFES #000665

### A. Initial Inspection/Disposal Criteria

- ✓ NOTE: Refer to Job Hazard Analysis (JHA) for proper personnel protection required when working on this item.
  1. Visually inspect for evidence of use (dust, oil, starter seal broken), damage or missing parts.
  2. Return to stock if:
    - a. there is no sign of use or damage
    - b. and date last tested (DLT) does not exceed 12 months.
  3. Refurbish as necessary if unit has been used, damaged, or shelf life is exceeded.
- ✓ If unit is not economically repairable it should be disposed of using local agency policy.

### B. Tests

- ✓ NOTE: Refer to the owners' manual for operations and specifications information specific to engine/roller model.
- ✓ Check condition of fuel and engine oil; ensure fuel is fresh and oil level is sufficient for running tests (see G.)
  1. Test function of rewind starter, ensure proper engagement of engine and recoil functionality.
  2. Check for damage or fraying of pull cord. Repair or replace as necessary.
  3. Engine should: start easily, run smoothly, be free from leaks (oil/fuel), and provide sufficient power to the hose rolling wheels.
  4. Ensure engine operational controls are functioning properly; stop switch, throttle and choke.
  5. Rolling wheels/pins should turn without v-belt slippage when foot pedals are depressed and should be easily stopped when foot pedals are released.

### C. Refurbishing Procedures

1. Clean unit as necessary (see section E.).
  2. Check condition of engine oil, spark plug and air filter; clean or replace as necessary.
  3. Check for loose and/or missing parts or mounting hardware; tighten or replace as needed.
  4. Inspect exhaust system; make sure there are no cracks or leaks.
  5. Clean spark arrestor of excess carbon build up, replace screen if damaged.
  6. Ensure all safety equipment (warning labels, metal screening, guards and shields) are in place and functioning properly.
  7. Check for and repair (weld) any cracks in frame structure.
  8. Lubricate bearings on pulley shafts and wheel bearings.
  9. Inflate tires to proper pressure (pneumatic tires).
  10. Test for performance. See B. Tests.  
Should any function fail a test, refer to the manufacturer's repair manual and troubleshooting guide to correct the problem.
  11. Remove all gasoline from fuel tank and fuel line.  
Run engine until carburetor is completely empty of gas (use choke).
  12. Prepare unit for storage. See F. Cleaning Procedures.
- ✓ NOTE: If this equipment is taken to a "factory authorized" repair facility for refurbishment ensure that they receive a copy of this refurbishment standard. The repair facility must satisfy both the requirements as set by the manufacturer specification and to the agreement made with the local agency.

Continued --

ITEM: **HOSE ROLLER**, gas

NFES #000665

**D. Retesting Criteria**

1. Retest if date last tested (DLT) is exceeded or starter seal is broken.
2. Ensure C. Refurbishing Procedures is completed.

**E. Cleaning Procedures**

1. Remove dirt and oil, using detergent or degreaser as necessary.
2. Use pressure washer to remove heavy soil.  
Use pressure washer, only if you will start and run the hose roller the same day.

**F. Repackaging**

1. Use nylon “zip-tie” to tie off (seal) starter rope to frame, to later determine if equipment has been used.
2. Attach certification tag; that indicates date last tested (DLT), property #, and name of individual certifying performance.
3. Ensure that all identification (property #, serial #, owner ID) is affixed and legible.
4. Attach a current “Hose Rolling” Job Hazard Analysis (JHA) to the frame.

**G. Storage and Shelf Life Checks**

1. Recommendation: Use a fuel stabilizer in fuel during testing to help ensure proper operation of engine at post storage start up.
2. Ensure date last tested (DLT) does not exceed 12 months.

**H. Reference**

[www.the-rookie.com](http://www.the-rookie.com)  
[www.hondapowerequipment.com](http://www.hondapowerequipment.com)  
[www.briggsandstratton.com](http://www.briggsandstratton.com),

NFES Cache Memo No. 09-01

[http://www.nifc.gov/nicc/logistics/cachememo/CM\\_09-1\\_Hose\\_Rollers.pdf](http://www.nifc.gov/nicc/logistics/cachememo/CM_09-1_Hose_Rollers.pdf)

## Fire Equipment Storage and Refurbishing Standards

---

ITEM: **INCREASERS**

NFES #000416, #000854, #002235

**A. Initial Inspection/Disposal Criteria**

1. Inspect for cracks, bad threads, or obvious damage, if any dispose of.
2. Inspect gaskets (refer to C1.)

**B. Tests**

Check threads by using appropriate female fitting.

**C. Refurbishing Procedures**

1. Replace gasket if stiff, missing, or cracked.
2. Inspect threads for damage. Use triangular file to “chase” threads.

**D. Retesting Criteria -- none**

**E. Cleaning Procedures**

1. Clean in parts washer, high pressure wash or clean in sink with mild detergent using a brush or scouring pad.
2. Rinse thoroughly.
3. Stand upright to drain and dry.

**F. Repackaging**

1. NFES #000416, package 10 each in carton (cache option) or 60 each in carton (cache option) and label accordingly.
2. NFES #000854, package 10 each in carton (cache option) or 60 each in carton (cache option) and label accordingly.
3. NFES #002235, package 10 each in carton (cache option) or 60 each in carton (cache option) and label accordingly.

**G. Storage and Shelf Life Checks -- none**

**H. Recycle as local cache options are available.**

ITEM: **JEAN, BDU**

All Sizes

**A. Initial Inspection/Disposal Criteria**

1. Inspect for holes, cuts, tears, burns, or torn seams if non-repairable dispose of.
2. Inspect for pant legs cut off and not repairable to a minimum of 30" inseam. Dispose of if non-repairable.
3. Inspect buttonholes for frayed or broken stitching and if non-repairable, dispose of.
4. Inspect all hook and pile fasteners to ensure that they provide adequate closure. If non-repairable dispose of.
5. Inspect zippers for broken or missing teeth and dispose of if non-repairable.
6. Inspect all belt loops to ensure that none are missing or broken. If non-repairable, dispose.
7. Inspect all side take-up tape or buckles if missing, damaged, or with loose thread (see C. Refurbishing Procedures note).
8. Jeans laundered to unknown specifications will be re-laundered following the guidelines in E.
9. Exposure to poison ivy/oak/sumac is NOT disposal criteria. However, extra care should be taken when handling contaminated clothing. Refer to Appendix A—Cleaning Instructions and Appendix A-- Nomex Clothing Exposed to Poison Oak/Ivy/Sumac

✓ **NOTE:** Lost or damaged cuff closure cord and side take-up tape should not be disposal criteria. It is not recommended to replace any lost or damaged cuff closure cords and side take-up tape.

**B. Tests**

Open and close the hook and pile fasteners to ensure that they provide adequate and secure closure.

Open and close zipper to ensure smooth operation and a secure closure.

**C. Refurbishing Procedures**

1. Repair holes, cuts, tears, burns, and torn seams by darning, patching, or by duplicating the original construction (see A. Initial Inspection/Disposal Criteria).
2. Use Nomex® (Aramid) patching material for all repairs.
3. Hemmed pant legs that change the inseam length shall indicate the new inseam length on the white sizing label on the inside of waist band.
4. Re-stitch frayed buttonholes using a buttonhole or zigzag stitch that has 50 to 60 stitches per buttonhole.
5. Replace damaged hook and pile fastener tape with tape of the same length, width, and quality as the original (see A. Initial Inspection/Disposal Criteria).
6. Replace damaged zipper with the same type, length, and quality as the original.
7. Replace damaged belt loops with loops of the same material and construction as the original (see A. Initial Inspection/Disposal Criteria).
8. Replace side take-up tape using Nomex® (Aramid) tape with a metal doublebar buckle.
  - a. The replacement tape should be 5/8" wide Aramid tape, style #70-6185-2007-5/8", color black. Order from:  
Offray Specialty Narrow Fabrics, Inc. Ph: 908-879-3636  
360 Route 24 Fax: 908-879-3630  
POB 421  
Chester, NJ 07930

## Fire Equipment Storage and Refurbishing Standards

---

Continued --

ITEM: JEAN, BDU

All Sizes

- b. The replacement buckle should be Albest Metal Stamping Corp. part # BB34010BD, 5/8" black or ITW Waterbury part # 004820921883. Order from:  
Albest Metal Stamping Corp.  
One Kent Ave  
Brooklyn, NY 11211-1014  
Ph: 203-753-1161

✓ NOTE: The first lot of pants manufactured in 2000 have thin light green side take-up tapes; later contracts have heavier black side take up-tapes. It is recommended that the loose end of the light green take-up tapes be replaced by the recommended Nomex® tape (#6 above). It is not necessary to replace the tape that is holding the metal tri-glide.

### D. Retesting Criteria

Test all replacement hook and pile fasteners, button holes and zippers after sewing in place, as specified in B. Tests.

### E. Cleaning Procedures

See [www.personalprotection.dupont.com](http://www.personalprotection.dupont.com)

See Appendix A--Cleaning Instructions

See Appendix A—Nomex Clothing Exposed to Poison Oak/Ivy/Sumac

DO NOT USE BLEACH TO CLEAN FABRIC.

### F. Repackaging

1. Close fly and all pocket flaps, properly thread side take-up tape, untie cuff cord.
2. With inseams meeting, fold pants from the leg bottom up toward the waist band to an overall length of about 23".
3. Pack 30 pairs of the same size pants in carton NFES #002007.

### G. Storage and Shelf Life Checks -- none

### H. Recycling

Leigh Fibers Inc.

Nelson Smith

1101 Syphirt Rd

Wellford, SC 29385

Ph: 864-439-4111

Make contact with vendor to establish requirements and feasibility.

ITEM: **KIT**, Coffee Heating

NFES #000480

**A. Initial Inspection Disposal Criteria**

1. Visually inspect kit components.
2. Dispose of bad hose lines, badly bent stove, urn, lid, and broken faucets.
3. Inspect to see that threaded pipe fittings inside the burner have been welded (completely around). If not, have done by a certified welder.

**B. Tests**

1. Connect stove and all fittings to propane source.
2. Turn on tank with valve in "OFF" position at burner.
3. Inspect connections for leaks with soapy water.
4. Light burner and make sure it is operable.
5. Reference the refurbishment standards for the inspection, testing and cleaning of propane tanks.

✓ **CAUTION: HAVE A FIRE EXTINGUISHER IN WORK AREA PRIOR TO LIGHTING BURNER**

**C. Refurbishing Procedures**

1. Clean heater components. Repaint if necessary with high-temperature paint.
2. Clean with soap and water and disinfect urn, basket, bucket, lid, and faucets.

**D. Retesting Criteria**

1. Concerns and questions about propane fittings, regulators, and propane tanks should be directed to an authorized service representative.

**E. Cleaning Procedures**

1. Use soap, water, and disinfectant to clean coffee urn, lid, and faucets.
2. Clean heater components.

**F. Repackaging**

Recommended carton is NFES #000500.

**G. Storage and Shelf Life -- none**

**H. Reference**

GSA Web <http://www.gsa.gov/fireprogram>

OPD Valves <http://www.p2pays.org/ref/14/13043.pdf>

## Fire Equipment Storage and Refurbishing Standards

---

ITEM: **KIT**, First Aid, 10-person, belt  
**KIT**, First Aid, type III, 24-person

NFES #001143  
#001604

**A. Initial Inspection/Disposal Criteria**

1. Inspect case and/or bag for excessive wear and cleanliness. Inspect belt and buckles for serviceability.
2. Open case and/or bag and inspect contents.
  - a. Standard updated packing slip should be utilized while inventorying contents.
  - b. Inspect contents and inspect expiration dates. Dispose of expired items.
  - c. Inspect any items that require sanitary package for tears or other damage: dispose of if torn or damaged.

**B. Tests -- none**

**C. Refurbishing Procedures**

1. Clean, repair, or replace case and/or bag as needed.
2. Replace damaged or expired items.

**D. Retesting Criteria -- none**

**E. Cleaning Procedures**

1. Clean case as necessary.
2. Follow Appendix A--Cleaning Instructions for bag.

**F. Repackaging**

1. Utilizing packing slip, replace items in elastic retainers or inside case.
2. Hook belt buckles together and fold against back of bag on belt kit.
3. Enclose in a clear plastic bag with kit label and expiration dates visible and then heat seal bag.
4. Package 10 each NFES #001143 in carton NFES #002007 and label accordingly.
5. Package 10 each NFES #001604 in carton NFES# 002030 and label accordingly.

**G. Storage and Shelf Life Checks**

1. Inspect expiration dates of contents annually.
2. Store in heated area.

**H. Reference**

GSA Web - <http://www.gsa.gov/fireprogram>

## Fire Equipment Storage and Refurbishing Standards

ITEM: **KIT**, longline, with remote hook  
 Kit Components

NFES #001309  
 NFES #000849, #000398, #000243

**KIT COMPONENTS:**

SECTION	NFES	DESCRIPTION
I	000849	LONGLINE, cable 50' with NEMA plugs
II	000398	CONNECTOR, pigtail
III	000243	HOOK, cargo, electric with brush guard

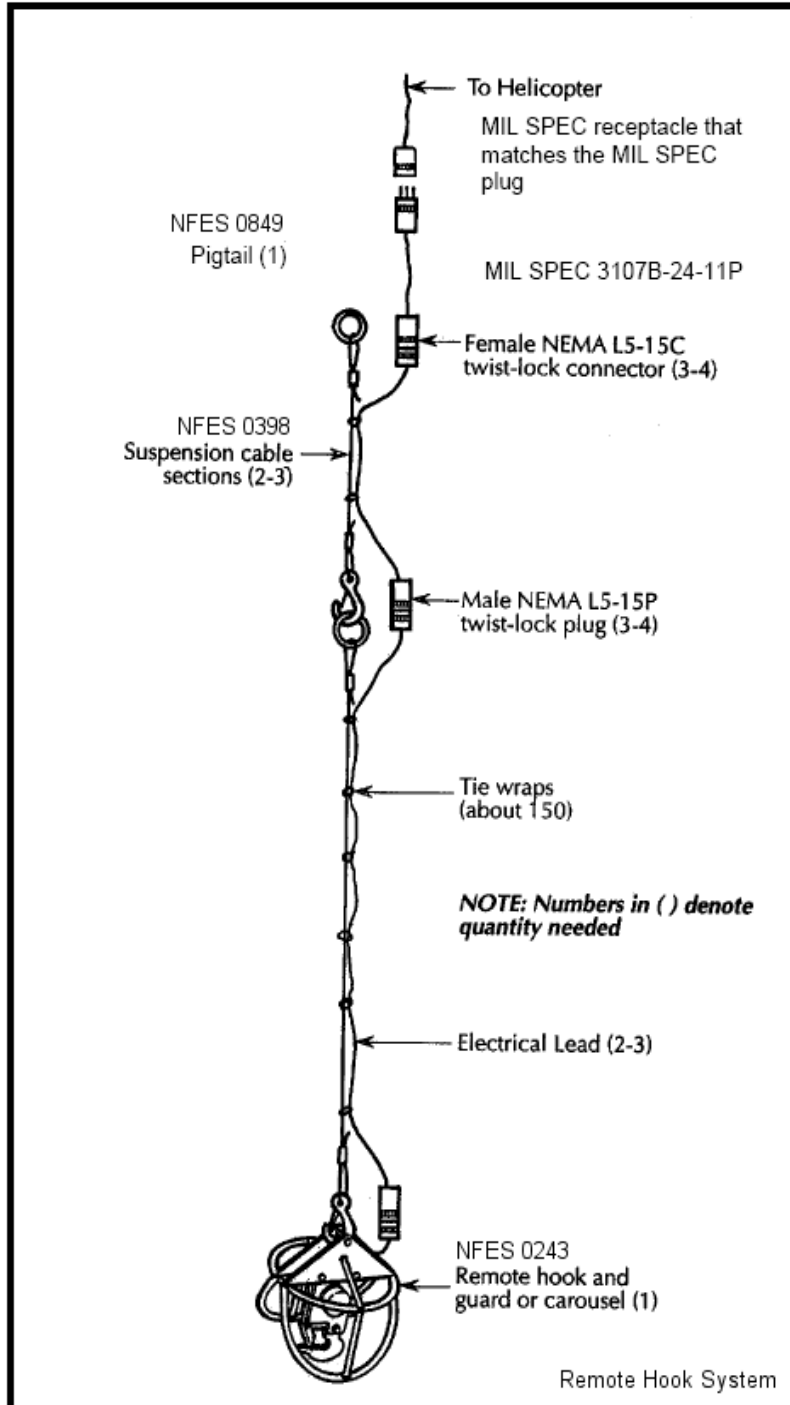
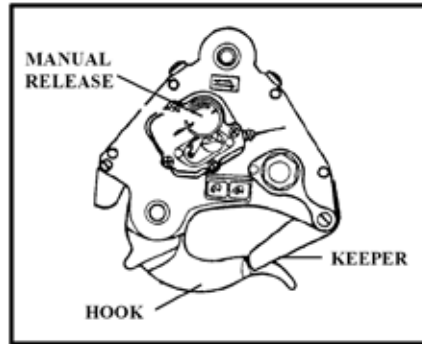

Figure 1. Remote Hook System.



ITEM: **HOOK**, cargo, electric w/brush guard

NFES #000243



**A. Initial Inspection/Disposal Criteria**

1. Inspect case and covers for damage. If damage is found, remove from service. See C.
2. Inspect brush guard for structural damage and loose bolts. If brush guard is damaged or distorted, remove from service. See C. Refurbishing.
3. Ensure safety latch is not bent.  
Inspect keeper operation, keeper should move smoothly from the hook and return to closed position.  
If keeper does not operate smoothly, remove from service. See C. Refurbishing
4. Visually inspect hook damage such as gouges, wear or distortion. If any damage is found, remove from service. See C. Refurbishing.
5. Operate manual release of hook; hook should rotate away from body when manual release is operated, if not remove from service. See C. Refurbishing.
6. Visually inspect electrical cable and connector for damage. If any damage is found, remove from service. See C. Refurbishing.
7. Testing electrical operation requires special tools and should be performed by an approved repair facility.

**B. Tests**

No local testing is recommended.

**C. Refurbishing Procedures**

All repairs for corrosion of the cargo hook must be authorized by an approved government maintenance inspector, FAA certified Airframe Mechanic, or FAA Repair Station.

**D. Retesting Criteria**

1. The hook assembly shall be functionally and proof tested every 5 years.
2. The hook can be proof functionally tested by any certified rigging company.  
Aero Accessory Service Phone 208-344-6461  
612 S. Scott  
Boise, ID 83705  
  
Field Support Services Phone 770-454-1130  
2001 Flightway Drive  
Atlanta, Georgia 30341

## Fire Equipment Storage and Refurbishing Standards

---

Continued --

ITEM: **HOOK**, cargo, electric w/brush guard

NFES #000243

Boise Rigging Supply  
106 W. 32<sup>nd</sup> St  
Garden City, ID 83714

Phone 208-342-8919, 800-342-7673  
Fax 208-342-8919

Bend Rigging Supply, LLC  
20650 High Desert Lane STE #6  
Bend, OR 97701

Phone: 541-318-8188  
Fax: 541-318-1730

**E. Cleaning Procedures**

The hook assembly may be cleaned with hot water. A light water-displacement oil (such as WD-40) may be used to displace water on the hook assembly. Any use of degreasing products during cleaning of the hook assembly will require the hook to be lubricated in accordance with the hook manufacturer's recommendations.

**F. Repackaging**

Local cache option.

**G. Storage and Shelf Life Checks -- none**

**H. Reference**

Interagency Helicopter Operations Guide (IHOG)

<http://www.nifc.gov/policies/ihog/chapters/2009chapter09.pdf>

<http://amd.nbc.gov/dts/tsdocs/tb04-03.pdf>

ITEM: **CONNECTOR**, pigtail

NFES #000398

**A. Initial Inspection/Disposal Criteria**

1. Inspect wire and connections for damage.
2. Broken wires (electrical cord).
3. Bent or distorted electrical connections.
4. Cuts, tears or frayed electrical wires.
5. Inspect the electrical cable:
  - a. Check for breaks in electrical leads and shorts. If broken wires or shorts are found replace electrical cable. See B. Tests.
  - b. Visually inspect the length of the electrical cable for cuts, tears, crushed or frayed wires. If cuts, tears or frayed wires are found, replace electrical cable. Replace electrical cable if broken wires discovered.
6. Check for damaged, bent or distorted electrical connections, repair or replace connector. Repair or replace bent or distorted electrical connections.

**B. Tests**

1. Check for breaks in electrical leads. Use a continuity checker, such as Ohmmeter or Continuity Tester. Place plugs side by side and place probe in their respective plugs. The continuity checker will light up if wires are unbroken. Also test for shorts by keeping one probe on the same plug and moving the opposite probe on the adjacent plugs. If continuity checker lights, then a short exist. If broken wires or shorts are found, replace electrical cable.
2. Check electrical connections per drawing FS/OAS A-16 accessory connector pin assignments: simplex helitorch, bambi bucket, remote hook, and seeders (2-wire). Electrical pin connections can be checked per the above drawing with an ohmmeter.

Information from FS/OAS A-16 accessory connector pin assignments:

<u>Pin</u>	<u>Function</u>
D	Aircraft Ground
E	+28VDC (Bucket/Hook Open & Torch/Seeder On)

**C. Refurbishing Procedures -- none**

**D. Retesting Criteria -- none**

**E. Cleaning Procedures**

Clean electrical connections with electrical cleaner, wipe, or blow dry.

**F. Repackaging**

Local cache option.

**G. Storage and Shelf Life Checks -- none**

**A. Initial Inspection/Disposal Criteria**

1. Inspect eye and swage for red paint and slippage. See B.1
2. Inspect wire rope for damage, wear and deformation. See B.2
3. Measure wire rope length. See B.3.
4. Check for identification tag that has the required information and is permanently attached. See B.4
5. Inspect thimbles for damage, wear, and deformation. See B.5
6. Inspect hook for damage, wear, and deformation. See B.6
7. Inspect hook safety gate for damage, wear and deformation. See B.7
8. Inspect ring and link for damage, wear, and deformation. See B.9
9. Inspect for missing tie wraps attaching electrical wire to wire rope. See B.10
10. Inspect electrical wire and connectors for damage, wear, and deformation. See B.10

**B. Tests and Retesting Criteria**

1. Swage and Cable Slippage
  - a. Visually inspect each swage and eye of the sling, for red paint. Red paint is required on the swage and wire rope in the area between the swage and the thimble eye, see Figure 1. If paint is not present, paint shall be applied to the indicated area slippage at the swage, and then sent to a qualified testing facility for proof load testing. See Figure 1. See C. Refurbishing.
  - b. Inspect swage and wire rope eyes for slippage. Swage termination shall be flush with the swage collar and extend no more than 0.125 inch from the swage collar. Slippage is indicated by the exposed or exposed and unpainted wire rope between the thimble and swage. See Figure 1. If slippage has occurred, dispose of the longline. See H. Salvage.

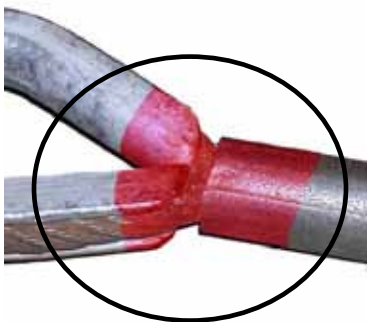

Figure 1. Painted swage.

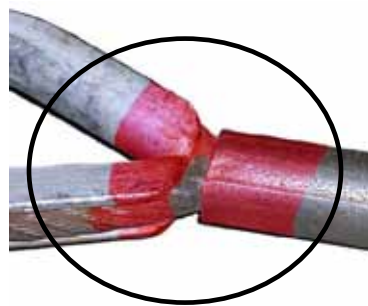

Figure 2. Paint showing slippage.

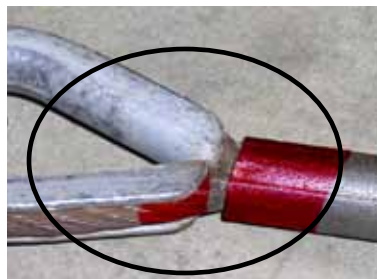

Figure 1. Painted slipped swage.

Continued --

ITEM: **LONGLINE**, cable 50' with NEMA plugs

NFES #000849

2. Wire Rope Construction consists of a number of wires grouped in strands and then a number of strands are wrapped around a core. Figure 3.

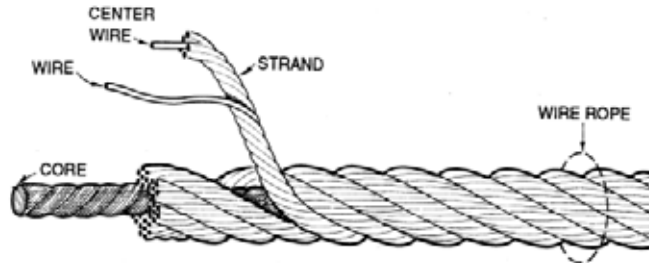

Figure 3. Wire Rope Construction

- a. Visually inspect length of wire rope for structural damage
- Severe kinks in wire rope, see Figure 4
  - Ballooning of wire rope, see Figure 5
  - Severe Corrosion,
  - Abrasion, wear over 1/3 the outer wire diameter, see Figure 7.
  - Reduction in diameter of wire rope.
- If any damage is found then dispose of the wire rope. See H. Salvage.



Figure 4. Kink



Figure 5. Ballooning

- b. Inspect length of wire rope for damage. Wear heavy protective gloves and run a dry rag over the entire length of the wire rope. Never use an ungloved hand to check the length of the cable. Flex wire rope to expose breaks. Snags indicate broken wires in the wire rope. If individual broken wires are found, they may be trimmed back. If 4 or more broken wires are found grouped together, then dispose of wire rope. See H. Salvage.

Continued --

ITEM: **LONGLINE**, cable 50' with NEMA plugs

NFES #000849

- c. Wire rope that is plastic coated shall be checked for damage. Abrasion to plastic coating down to the wire rope may cause corrosion. Run gloved hand over length of plastic coated wire rope to check for any abnormalities, such as lumps, depressions and exposed wire. If wire rope has severe damage or corrosion is found or wire rope is exposed and damaged, dispose of plastic coated wire rope. See Figure 6 and 7. See H. Salvage.



Figure 6. Damaged plastic coated wire rope.



Figure 7. Abrasion and Corrosion extends through plastic coating to wire rope.

3. Wire Rope Length.

Check wire rope length, measure inside loaded surface of the hook to the inside loaded surface of the ring. If wire rope length exceeds tolerance dispose of properly. See H. Salvage.

Table 1. Wire Rope Length

Length	Tolerance
50 feet	+ 0 / -1 inches per 5100-500e
100 feet	+0 / -1 inches per 5100-500e

4. Proof Load Tag

Visually inspect longline for permanently attached tag. Proof load tag shall be permanently attached with a swaged stainless steel wire rope; temporary attachments are not allowed, such as wire ties. Tag shall contain at a minimum the following information: Manufacture Name, Working load and Date of Test (i.e. 06/06 for June, 2006) If permanently attached proof load tag is not present, missing required information or attached with a non-permanent tag remove the longline from service, Test must be performed by qualified testing personnel/facility and attach identification tag. See C. Refurbishing B.

Continued --

ITEM: **LONGLINE**, cable 50' with NEMA plugs

NFES #000849



Figure 8. Thimble and Pear Link.



Figure 9. Deformed Thimble and Hook.

5. Thimble

Inspect thimble for cracks, wear, and deformation. Physically examine each thimble for movement by forceful motion with hand, thimbles may move but should not be loose. Thimble shall have a smooth arc, see Figure 8. If thimbles have any cracks, wear, deformation or are loose, dispose of longline. See Figures 8 and 9. See H. Salvage.

Table 2. Hook Dimensions

H (max)	J (min)
1.50 inch	0.75 inch

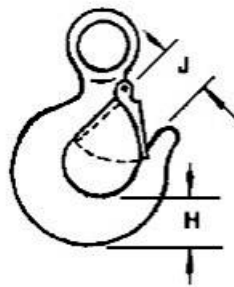

**Safety Latch Hook**



Continued --

ITEM: **LONGLINE**, cable 50' with NEMA plugs

NFES #000849

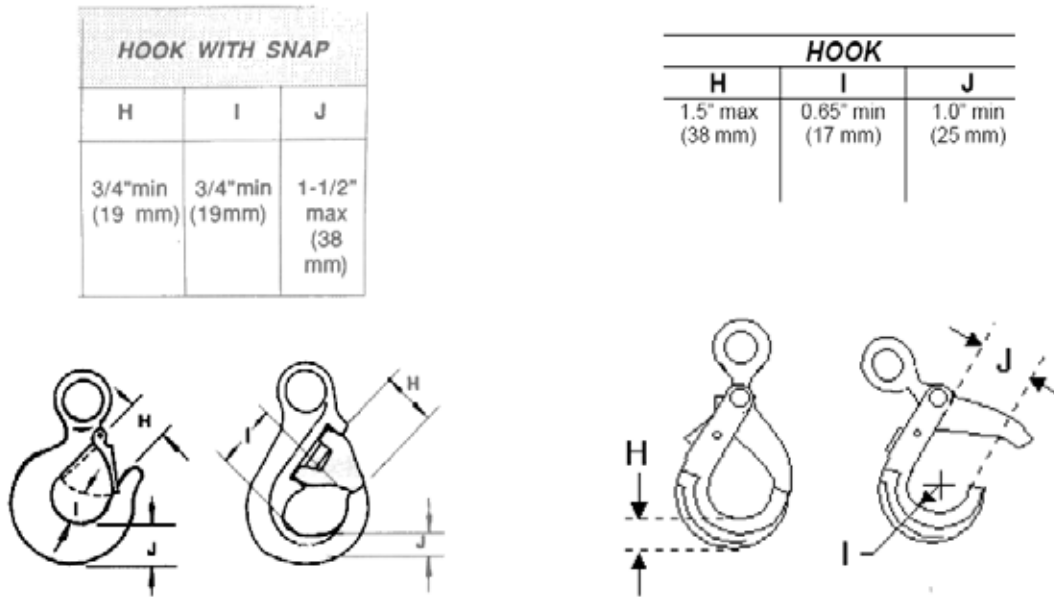

Figure 10. Dimension for Hooks

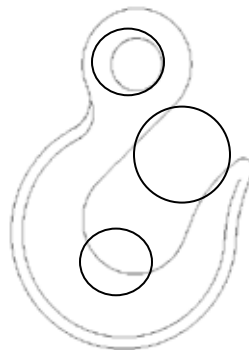

Figure 11. Check Hook for damage at the circled I Locations to check for damage on Hook.

6. Hook (Safety Gate and Locking Safety Latch)
  - a. Inspect hook, Check hook for damage such as cracks, nicks, wear, gouges, and deformation. See Figure 10 and 11. Check operation and ensure that hook is not bent or distorted. If any damage, deformation or wear are is found, then remove from service. See H. Salvage.
  - b. Check hook's gate operation.
    - Ensure gate fully opens and closes completely
    - Inspect for gate that is damaged, bent, or distorted,
    - Gate shall have either rivet or bolt with self locking nut.
 If gate is damaged, does not operate as required, missing required hardware remove from service, see C. Refurbishing.  
 See H. Salvage



Continued --

ITEM: **LONGLINE**, cable 50' with NEMA plugs

NFES #000849

7. Hook (Safety Gate Type)

Check hook's gate operation.

- Does it close completely?
- Is the gate damaged or distorted?
- If used does the gate bolt have a self locking nut?
- Check Hook Dimensions, See Figure 10.
- If gate is damaged, does not operate as required, missing hardware, or does not meet dimensional requirements remove from service. See H. Salvage

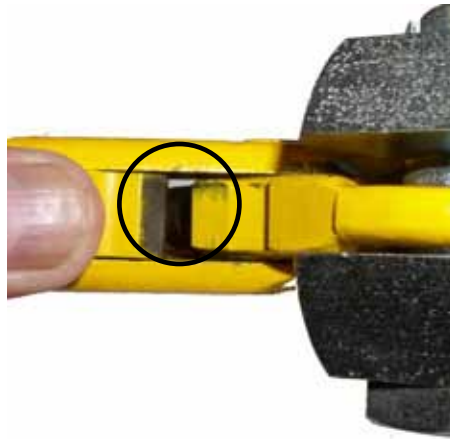

Figure 11. Examine Gate Lock Latch for rounding.

8. Hook (Gate Lock Latch)

Check hooks locking safety latch operation.

- Does it open and close completely?
- Does the spring loaded latch hold the latch in the closed position?
- Check lock latch for rounded edge. See Figure 11.
- Is the latch damaged or distorted?
- Check Hook Dimensions. See Figure 10.

If latch is damaged, does not operate as required, missing hardware, or does not meet dimensional requirements remove from service. See H. Salvage

9. Ring or Link

Inspect ring or link.

- Check for damage such as cracks, nicks, wear, and gouges.
- Check dimensions for deformations. See Figure 12.

If ring or link is damaged then remove from service. See H. Salvage.

Continued --

ITEM: **LONGLINE**, cable 50' with NEMA plugs

NFES #000849

Table 3. Ring and Pear Link Dimensions

<i>ALL</i>	<i>RING</i>	<i>OBLONG LINK</i>		<i>PEAR LINK</i>		
<b>A</b>	<b>B</b>	<b>C</b>	<b>D</b>	<b>E</b>	<b>F</b>	<b>G</b>
5/8" max (15.8 mm)	3" min (76 mm) 4" max (102 mm)	3" min (76 mm) 4" max (102 mm)	1-1/2" min (38 mm) 3" max (76 mm)	3" min (76 mm) 4" max (102 mm)	3" max (76 mm)	1/2" min (12 mm)

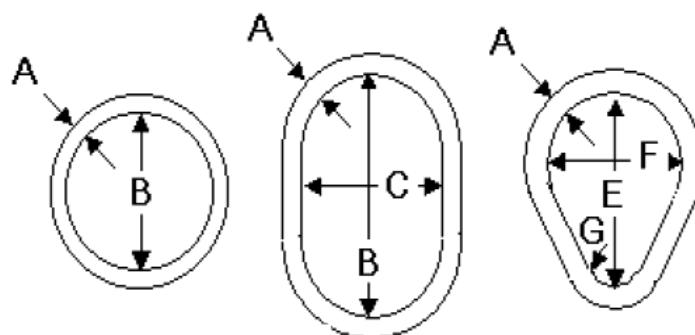

	<b>A</b>	<b>B</b>	<b>C</b>
Ring or Pear Link	5/8 inch max	3 – 4 inch	3 – 4 inch

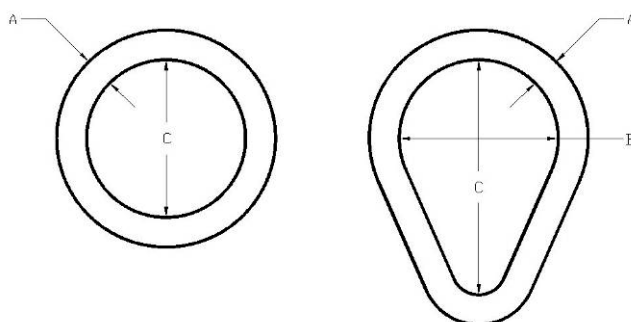

Figure 12. Dimension for Ring, Oblong Link and Pear Link.

10. Electrical Cable
  - a. Check for missing nylon tie wraps. Tie wraps shall be located two at each end and then every ten feet. Replace missing or broken nylon tie wraps. See Figure 1.
  - b. Inspect the electrical cable:
    - Use a continuity checker, such as ohmmeter or light to check for breaks in electrical leads. Place NEMA plugs side by side and place probe on their respective plugs. The continuity checker will light up if wires are unbroken. Also test for shorts by keeping one probe on the same plug and moving the opposite probe on the adjacent plugs. If continuity checker lights, then a short exist. If broken wires or shorts are found replace electrical cable.

Continued --

ITEM: **LONGLINE**, cable 50' with NEMA plugs

NFES #000849

- Visually inspect the length of the electrical cable for cuts, tears, crushed or frayed wires. If cuts, tears or frayed wires are found, replace electrical cable. Replace electrical cable if broken wires discovered.
- c. Check for damaged, bent or distorted electrical connections, repair or replace connector. Repair or replace bent or distorted electrical connections.

**B. Tests and Retesting Criteria**

Proof tests can be performed by any local certified rigging company when:

Repaired sections shall be tested at twice the rated working load prior to being returned to the available stores system.

The wire rope shall be proof tested every 5 years.

**C. Refurbishing Procedures**

1. Repairs to wire rope should be completed by qualified testing personnel. See B. Tests.
2. Proof tests must be performed by a certified rigging company when:
  - a. Repaired sections shall be tested at twice the rated working load prior to being returned to the available stores system.
  - b. The wire rope shall be proof tested every 5 years.
3. Any certified rigging company can test the leadline assembly.

**D. Retesting Criteria**

1. Repaired sections shall be tested at twice the rated working load prior to being returned to the available stores system.
2. The wire rope and hook assembly shall be proof and functionally tested each 5 years.

**E. Cleaning Procedures**

1. The cable and hook assembly may be cleaned with hot water. A light water-displacement oil (such as WD 40) may be used to displace water on the hook assembly. Any use of degreasing products during cleaning of the hook assembly will require the hook to be lubricated in accordance with the hook manufacturer's recommendations. Never use heavy grease or engine oil to lubricate wire rope.
2. The wire rope may be cleaned with hot water.

**F. Repackaging**--Local cache option.

**G. Storage and Shelf Life Checks** -- none.

**H. Salvage**

1. Salvage all useable hardware (link and hook) and connectors prior to disposing of longline and cable. Salvaged material can be sent to San Dimas Technology and Development Center. Label the container: "*Salvaged Material from \_\_\_\_\_ Cache.*"
2. Segregate 3000 lb capacity equipment from 6000 lb capacity equipment.
3. Salvage all useable hardware and connectors prior to disposing of longline and cable. Salvage material can be sent to San Dimas Technology and Development Center.

**I. Reference**

[http://amd.nbc.gov/safety/library/alerts/IA\\_08-08.pdf](http://amd.nbc.gov/safety/library/alerts/IA_08-08.pdf)

---

## Fire Equipment Storage and Refurbishing Standards

---

ITEM: KIT, Shelter, 15' X 27'	NFES #000430
KIT, Shelter, 16' octagon	NFES #000550
KIT, Shelter, 18' octagon	NFES #000540
KIT, Shelter, 20' octagon	NFES #000549

### A. Initial Inspection/Disposal Criteria

1. Inspect packing list and instructions.
2. Assemble the mainframe and components according to instructions.
  - a. All locking pins and flex joints should move easily.
  - b. Inspect for burrs on all components of mainframe, even bars, and base bars.
  - c. Loosen flex joints and remove burrs as needed.
3. Inspect and install door; should open and close easily.
4. Inspect roof and wall panels for any tears or rips and repair as needed.
5. Inspect windows and screens in wall panels. (Repair or replace where necessary)
6. Check for broken welds on key flange, repair by bolting.

### B. Tests -- none

### C. Refurbishing Procedures

1. Repair or replace any part of the main frame as needed. Bolt key flange.
2. When dismantling, wipe all component parts with a damp cloth and return to proper container.
3. Inspect roof and wall panels for any holes, tears or rips, repair as needed.
4. Clean the roof and wall panels with a mild soap and water solution using a brush to remove hard dirt and grime or high-pressure wash.
5. Ensure that all locking buttons snap into place.
6. Ensure that the Velcro is dry on all panels before folding and placing in proper container.
7. Stencil main frame with property number, stencil inside the center roof ring.
8. Ensure that all kit components are accounted for prior to repacking.

### D. Retesting Criteria -- none

### E. Cleaning Procedures

1. Clean main frame and misc. parts with a damp cloth and mild detergent if necessary.
2. Clean the roof and wall panels with a mild detergent and water solution. Use a brush to remove hard dirt and grime or high pressure wash.

### F. Repackaging

1. Repack according to manufacturer's instructions and local cache standards.
2. Ensure that installation/assembly instructions are included in package.

### G. Storage and Shelf Life Checks -- none

### H. Reference

Major repairs and replacement parts may be obtained by contacting:

Western Shelter Systems  
830 Wilson Street  
Eugene, OR 97402

Phone: 541-344-7267

<http://www.westernshelter.com>

ITEM: **LADDER**, step, 8' fiberglass

NFES #000586

**A. Initial Inspection/Disposal Criteria**

1. Inspect for damage, nicks, and gouges, cracked or broken parts; dispose.
2. Inspect for paint, if covered with large amount—dispose.
3. Inspect footpads, if missing, damaged or worn replace with matching set.
4. Inspect steps, if loose, missing or damaged—dispose.
5. Inspect legs for damage if so, dispose of.
6. Inspect pail platform for damage. Repair or replace.
7. Inspect ladder for cracks, breaks, rough or splintered surfaces, if so dispose of.
8. Inspect ladder for oil and grease. Clean.
9. Inspect ladder hinge supports and cross supports for damage, if so dispose of.
10. Inspect ladder for missing cross supports, if so dispose of.
11. Inspect for twisted or distorted rails, if so dispose of.
12. Inspect for loose screws, bolts, nuts or rivets and repair.
13. Inspect for corrosion oxidization, and excessive wear especially on the treads.
14. Dispose of any wooden ladder.

**B. Tests**

1. Visual inspection of all ladder steps, ladder legs, and ladder cross supports.
2. Set up ladder and check for stability.

**C. Refurbishing Procedures**

See E. Cleaning Procedures.

**D. Retesting Criteria**

Visually inspect ladder steps, ladder legs, ladder foot pads, and ladder cross supports.

**E. Cleaning Procedures**

1. Fiberglass:
  - a. Remove all oil and grease.
  - b. Clean with soap and water or power wash.
  - c. Air dry.

**F. Repackaging**

Local cache option.

**G. Storage and Shelf Life Checks**

If stored upright, must be securely strapped to prevent falling.

**H. Reference**

GSA Web [www.gsa.gov/fireprogram](http://www.gsa.gov/fireprogram)

Ladder inspection [http://www.ccohs.ca/oshanswers/safety\\_haz/ladders/inspection.html](http://www.ccohs.ca/oshanswers/safety_haz/ladders/inspection.html)

## Fire Equipment Storage and Refurbishing Standards

---

ITEM: **LANTERN**, camp, electric, fluorescent

NFES #002501

**A. Initial Inspection/Disposal Criteria**

Inspect for broken lens, cracked cases, missing bulbs, and broken switches, replace or dispose of.

**B. Tests**

Install batteries to test operation of switch and bulbs.

**C. Refurbishing Procedures**

1. Clean as necessary, remove batteries and repair as needed.

2. Replace bulbs if necessary

USE APPROPRIATE REPLACEMENT BULBS

F6T5/CW (6 watt)

F9W (9 watt)

HS/S15W/6500K (15 watt)

**D. Retesting Criteria**

Only if needed.

**E. Cleaning Procedures**

Use soft cloth to clean lens and battery compartment.

**F. Repackaging**

Local cache options.

**G. Storage and Shelf Life Checks -- none**

**H. Reference**

<http://www.gsa.gov/fireprogram>

ITEM: **LEADLINE**, helicopter, external loads, 6,000 lb  
**LEADLINE**, helicopter, external loads, 3,000 lb

NFES #000380  
NFES #000528

**A. Initial Inspection/Disposal Criteria**

1. Inspect eye and swage for red paint and slippage, see B.1
2. Inspect wire rope damage, see B.2
3. Measure wire rope diameter and length, see B.3.
4. Check for identification, see B.4
5. Inspect thimbles, see B.5
6. Inspect hook for damage, wear, and deformation, see B.6
7. Operate hook safety gate, see B.7
  - If hook has a safety latch retrofit with self-locking safety gate.
8. Inspect ring and link, see B.8

**B. Tests and Retesting Criteria**

1. Swage and Cable Slippage
  - a. Inspect swage and wire rope eyes for slippage. If slippage has occurred, see figure 2, dispose of the leadline. See H. Salvage.
  - b. Visually inspect each swage and eye for red paint, if the paint shows that slippage has not occurred, but the paint is worn in such a way that this determination was difficult, the swage shall be repainted see C. Refurbishing Procedures. If paint is not present, send to certified rigging specialist for evaluation. See H. Salvage.

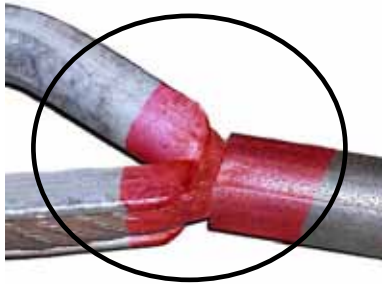

Figure 1. Painted swage.

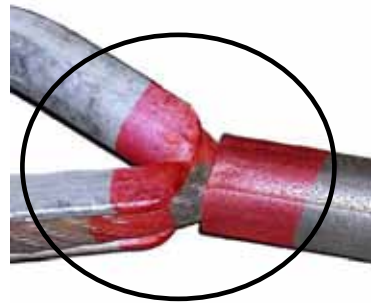

Figure 2. Paint showing slippage

2. Wire Rope-- If any damage is found then dispose of the wire rope (see H. Salvage.)
  - a. Visually inspect length of wire rope for structural damage
    - Kinks in wire rope (see figure 3.)
    - Ballooning of wire rope (see figure 4.)
    - Severe Corrosion
    - Abrasion, wear over 1/3 the outer wire diameter (see figure 6.)
    - Reduction in diameter of wire rope.

Continued –

ITEM: **LEADLINE**, helicopter, external loads, 6,000 lb  
**LEADLINE**, helicopter, external loads, 3,000 lb

NFES #000380  
NFES #000528



Figure 3. Kink



Figure 4. Balloning



Figure 5. Damaged plastic coated wire rope.



Figure 6. Abrasion

- b. 6000 pound leadline--inspect length of wire rope for damage.
  - Wear heavy protective gloves. Never use an ungloved hand to check the length of the cable.
  - Run a dry rag over the entire length of the wire rope.
  - Flex wire rope to expose breaks. Snags indicate broken wires in the wire rope. If individual broken wires are found, they may be trimmed back. If 4 or more broken wires are found grouped together, then dispose of wire rope. See H. Salvage.
  
- c. 3000 pound leadline--inspect plastic coated wire rope for damage. Abrasion to plastic coating down to the wire rope may cause corrosion.
  - Run gloved hand over length of plastic coated wire rope to check for any abnormalities, such as lumps, depressions and exposed wire. If plastic coated wire rope has severe damage or corrosion dispose of properly. See figure 5. See H. Salvage.



## Fire Equipment Storage and Refurbishing Standards

Continued –

ITEM: **LEADLINE**, helicopter, external loads, 6,000 lb  
**LEADLINE**, helicopter, external loads, 3,000 lb

NFES #000380  
NFES #000528

3. Measure wire rope for length and diameter
  - a. Check wire rope length.
    - Length is measured from center of each thimble. If wire rope length exceeds tolerance, dispose of properly. See H. Salvage.

Table 1. Wire Rope Length

Length	Tolerance per FSS 5100-503/505
12 feet	+/-3 inches
25 feet	+/-3 inches
50 feet	+/-3 inches

- b. Measure wire rope diameter at 3 points--12 feet from each end and at middle. Dispose of wire rope that exceeds tolerance.

Table 2. Wire Rope Diameter

Size	Dimension
3000 lb	5/16 inch to 5/8 inch
6000 lb	1/2 inch to 9/16 inch

#### 4. Proof Load Tag

- a. Visually inspect leadline for permanently attached tag. Proof load tag shall be permanently attached with a swaged stainless steel wire rope.
- b. Temporary attachments are not allowed, such as wire ties.
- c. Tag shall contain at a minimum the following information: Manufacture Name, Test Company or Trademark; Working load; and Date of Proof Test (i.e., 06/06 for June, 2006).
- d. If permanently attached proof load tag is not present, missing required information, not made of metal or secured with a non-permanent attachment device (e.g. Ty-Rap zip ties), remove the leadline from service (see C. Refurbishing Procedures.)



Figure 7. Thimble, Pear Link and Proof Load Tag.



Figure 8. Deformed Thimble and Hook.

Continued –

ITEM: **LEADLINE**, helicopter, external loads, 6,000 lb  
**LEADLINE**, helicopter, external loads, 3,000 lb

NFES #000380  
 NFES #000528

5. Thimble--Inspect thimble for cracks, wear, and deformation.
  - a. Physically examine each thimble for movement by forceful motion with hand.
  - b. Thimble may move but should not be loose within the eyelet.
  - c. Thimble shall have a smooth arc (see figure 7.) If thimbles have any cracks, wear, deformation or are loose (see figure 8), dispose of leadline (see H. Salvage.)

Table 3. Hook Dimensions

Leadline Capacity	Style	H (max)	J (min)
3000 lb	Self-locking hook	1.0 inch	1.33 inches
6000 lb	Self-locking hook	1.33 inches	1.7 inches

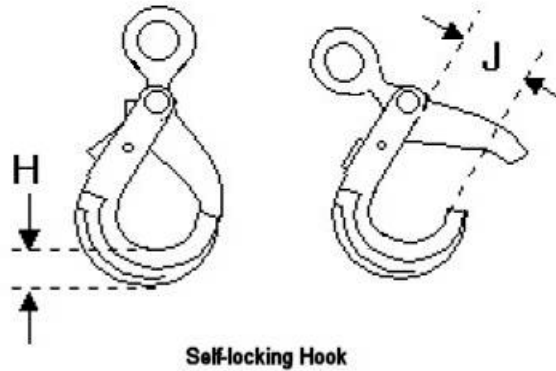

Figure 10. Dimension for Hooks

6. Hook (Safety Gate and Self-locking)
  - a. Check hook for damage such as cracks, nicks, wear, gouges, and deformation (see figure 11.)
  - b. Ensure that hook is not bent or distorted.
  - c. Check hook dimensions (see table 3 and figure 10).
  - d. If hook is damaged, distorted, does not meet dimension requirements, then remove leadline from service, see H. Salvage.

Continued –

ITEM: **LEADLINE**, helicopter, external loads, 6,000 lb  
**LEADLINE**, helicopter, external loads, 3,000 lb

NFES #000380  
 NFES #000528

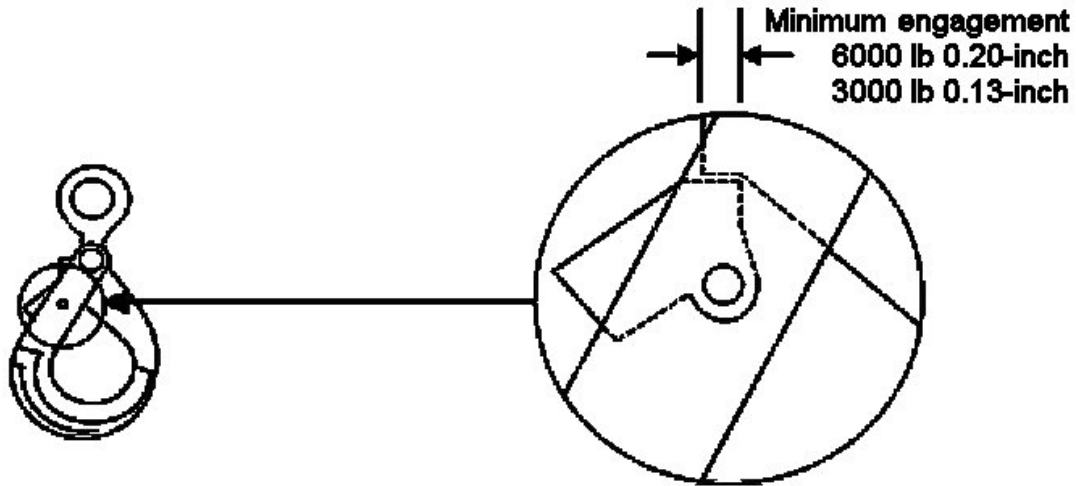

Figure 11. Examine Gate Lock Latch for rounding.

7. Hook (self-locking)
  - a. Check hook's locking safety gate operation.
    - Ensure safety gate opens and closes completely.
    - Examine gate for damage or distortion.
    - Examine gate lock for rounded edge (see figure 11.)
    - Ensure lock latch pin is secure and flush with the latch (see figure 11.)
  - b. If latch is damaged, does not operate as required, missing hardware, or does not meet dimensional requirements, remove from service. See H. Salvage.
  
8. Ring or Link
  - a. Inspect ring or link.
    - Check for damage such as cracks, nicks, wear, and gouges.
    - Check dimensions for deformations (see figure 12.)
  - b. If ring or link is damaged then remove from service. See H. Salvage.

Table 3. 3000 lb. Leadline Ring and Pear Link Dimensions

	A	B	C
3000 lb Leadline	$\frac{5}{8}$ inch max	1.5 – 3 inch	3 – 4 inch
6000 lb Leadline	0.63 inch max	1.5 – 3 inch	3 – 4.5 inch

Continued –

ITEM: **LEADLINE**, helicopter, external loads, 6,000 lb  
**LEADLINE**, helicopter, external loads, 3,000 lb

NFES #000380  
NFES #000528

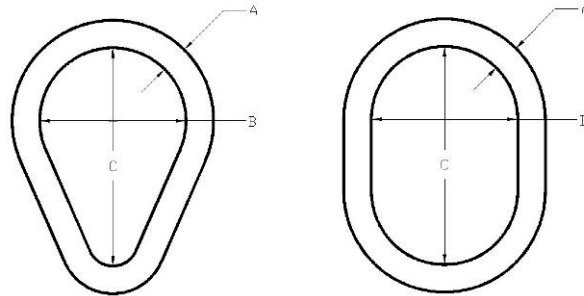

Figure 12. Dimension for Pear Link and Oblong Link.

**C. Refurbishing Procedures**

1. Replace damaged or missing safety gates from paragraph B.7.a.  
The attachment screw shall use a self-locking nut.
2. Apply slippage paint to the swage and thimble as shown in figure 13.  
The paint shall be a red spray epoxy or acrylic.  
Mask or cover the area to achieve a painted area similar to figure 13.  
Spray around the swage and do not attempt to spray paint into the ends of swage.
3. If the *Proof Load Tag* is missing, the leadline must be sent to a rigging company to be tested in per D. Retesting Criteria, as long as the item passed all other inspections.
4. Upon successful test, the rigging company shall apply a *proof load tag* that meets/includes the following:
  - safe working load in lbs.
  - date of proof test (month and year)
  - name or trademark of the rigging company
  - text size shall be 0.12 inches in height
  - tag shall either be stainless steel or brass
  - tag shall be secured to the leadline with a metal device (e.g., ‘hog ring’, wire cable)



Figure 13. Swage Paint.

## Fire Equipment Storage and Refurbishing Standards

---

Continued –

ITEM: **LEADLINE**, helicopter, external loads, 6,000 lb  
**LEADLINE**, helicopter, external loads, 3,000 lb

NFES #000380  
NFES #000528

**D. Retesting Criteria.**

1. Proof tests must be performed by a certified rigging company when:
  - the tag is missing and the leadline is otherwise acceptable
  - it makes economic sense.
2. The proof test shall apply a load to the item at twice the rated safe working load
3. Any certified rigging company can test proof test the leadline assembly.

**E. Cleaning Procedures**

The cable and hook assembly may be cleaned with hot water only, no soap.

**F. Repackaging**

Local cache option.

**G. Storage and Shelf Life Checks -- none.**

**H. Salvage**

1. Salvage all useable hardware (link and hook) prior to disposing of leadline.
2. Salvaged material can be sent to San Dimas Technology and Development Center.  
Label the container, "*Salvaged Material from \_\_\_\_\_ Cache.*"
3. Segregate 3000 lb capacity equipment from 6000 lb capacity equipment.

**I. References.**

NFES Cache Memo 08-02 <http://www.nifc.gov/nicc/logistics/cachememo/CM08-2.pdf>  
USFS SDTDC *3,000 Pound Leadline Retrofit*  
<http://fsweb.sdtc.wo.fs.fed.us/pubs/pdf/08571304.pdf>

ITEM: **LITTER, S.K.E.D.**

NFES #001670

**A. Initial Inspection/Disposal Criteria**

1. Inspect if bloodstained, alert supervisor for further instructions.
2. Inspect visually for cuts or tears in plastic surface, soiled surface, missing parts such as straps or fasteners. Repair or dispose of.
3. Inspect for structural damage such as grommets pulled out. Repair or dispose.
4. Inspect all straps; handles (web gear) are intact and functional, if not repair or dispose of.

**B. Tests -- none.**

**C. Refurbishing Procedures**

1. If plastic is cut or torn and cannot be economically repaired, remove from service.
  - Retain all serviceable components for replacement on other litters.
2. Wash S.K.E.D. with a disinfectant and warm water.
3. Wash with power washer and hang to dry.
4. Replace worn or damaged straps or fasteners.

**D. Retesting Criteria**

Reassemble to ensure completeness and all parts are fitting properly.

**E. Cleaning Procedures**

Completed in C. Refurbishing Procedures.

**F. Repackaging**

1. Roll up S.K.E.D. (using rubber gloves for better grip) small enough to fit into case.
2. Fasten retaining strap tightly so S.K.E.D. can be easily extracted.

**G. Storage and Shelf Life Checks -- none**

**H. Reference**

For information and parts lists see:  
SKEDCO, Inc.  
PO Box 230487  
Portland, OR. 97281

Phone: 800-770-7533  
Web site: <http://www.skedco.com>

GSA Web-- <http://www.gsa.gov/fireprogram>

## Fire Equipment Storage and Refurbishing Standards

---

ITEM: **McLeod**, with plastic sheath, 11”wide

NFES #000296

✓ [Note: Check local Job Hazard Analysis for proper personnel protective equipment required when refurbishing this item.](#)

### A. Initial Inspection/Disposal Criteria

1. Obvious damage to cutting edge, rake fingers, and handle. (Repair or Dispose)
2. Broken blade. (Dispose)
3. Loose head. (Dispose)
4. Missing or severely bent fingers. (Dispose)
5. Short or nonstandard handle. (Dispose)

### B. Tests

1. Head
  - a. Blade to be at least 10 to 14 inches wide from handle base. USE TEMPLATE
  - b. Handle base not tilted, bent, or distorted.
  - c. Blade ends have not been rounded or severely tapered so that they cannot be ground to specifications.
  - d. Proper angle of cutting edge as per tool sharpening gauge NFES #000510.
2. Handle
  - a. Handle must be straight.
  - b. Inspect for cracks, chips, or open grain.
  - c. Head loose on handle (loose or missing rivets).
  - d. Inspect for tape residue, or other residue (tar, sap, etc.).

### C. Refurbishing Procedures

1. Head
  - a. Remove dirt and grime from head with wire brush or hose.
  - b. Square up blade if necessary.
  - c. Sharpen cutting edge 1/8-inch wide at 50° angle. Ensure that blade corners are square.
  - d. Check large nut on head and tighten or replace as needed. Sharply strike rivet to tighten head to handle as needed.
2. Handle

Sand handle if it is chipped, dinged, rough, or has any type of residue.

### D. Retesting -- none

### E. Cleaning Procedures

See C. Refurbishing Procedures.

### F. Repackaging

1. Install plastic sheath NFES #001854.
2. Package 10 each in carton NFES #000305 (56” X 20” X 11”) (NSN 8115-00-139-0690).

### G. Storage and Shelf Life Checks

Inspect once per year for rust and loose handles

### H. Reference [New and Improved Flap Cup Grinder Disc](#)

### I. Recycle as local options are available.

## Fire Equipment Storage and Refurbishing Standards

---

ITEM: NET, cargo, 12' X 12', polypropylene, 3000 lb capacity	NFES #000531
NET, cargo, 15' X 15', 6000 lb capacity	NFES #000458
NET, cargo, lightweight, 10' X 10', 300 lb capacity	NFES #000695

### A. Initial Inspection/Disposal Criteria

1. Inspect for fraying or deterioration of lines.
  - If more than 10 percent of strands in any two adjacent cycles of the net are broken, dispose of. <http://www.nifc.gov/policies/ihog/chapters/2009chapter09.pdf>
2. Inspect netting for contamination by fuel oils or other liquids considered degenerative to netting.
3. Any NFES #000695 net that has black mesh must be taken out of service.
4. Verify identification tag is attached to net: 300#/3,000#/6,000#. If not attach one.
  - Replacement tag info should include NFES #, Safe Working Load (SWL) in pounds, i.e., 3,000 lb/6,000 lb, cache identifier and date.
5. Inspect loop thimbles for cracks, wear, and deformation. Ensure thimbles are not loose from net and easily removed.

### B. Tests

Brittleness: Test by bending several areas of the nets rope 180° back on itself. If more than 2 strands break per bend, dispose of net or return to manufacturer for repair.

### C. Refurbishing Procedures

1. Lay out net and inspect all ropes for fraying, burns, or wear points.
2. Clean all dirt from netting.
3. Remove all flagging, string, and rope.

✓ NOTE: On some heavy cargo nets, the mesh intersections are fixed with molded plastic crosses. These should be visually inspected for cracks and missing parts whenever the loop thimbles are inspected.

### D. Retesting Criteria -- none

### E. Cleaning Procedures

Hang or stack polypropylene nets and clean with water from high-pressure hose.

### F. Repackaging

Suggested cartons are:

- NFES #000531 net: package in carton NFES #002006 (23" X 19" X 10") (NSN 8115-00-139-0722). Label accordingly.
- NFES #000458 net: package in carton NFES #002007 (24" X 16" X 16") (NSN 8115-00-292-0123). Label accordingly.
- NFES #000695 net: package in carton NFES #002006 (23" X 19" X 10") (NSN 8115-00-139-0722). Label accordingly.

### G. Storage and Shelf Life Checks – none

### H. References

IHOG <http://www.nifc.gov/policies/ihog/chapters/2009chapter09.pdf>

Cache Memo 03-4 [http://www.nifc.gov/nicc/logistics/cachememo/cm\\_cargonet.pdf](http://www.nifc.gov/nicc/logistics/cachememo/cm_cargonet.pdf)



---

## Fire Equipment Storage and Refurbishing Standards

---

ITEM: **NOZZLE**, combination, barrel, KK 1" & 1½"  
**NOZZLE**, plastic, 35 GPM, 1" & 60 GPM, 1½"

NFES #001081, #001082  
NFES #000137, #000138

### A. Initial Inspection/Disposal Criteria

1. Inspect for obvious damage:
2. Inspect for burrs and cracks.
3. Inspect gasket. Replace if missing, cracked, or stiff.
4. Inspect screw or washer.
5. Must turn freely.
6. Inspect for fire damage--may cause failure in the future.
7. Inspect hose coupling threads for damage.
8. Old style KK: Inspect threads inside of barrel; if they show--dispose of.

### B. Tests

1. Pressure testing: turn on pump to 300 PSI.
2. Inspect for leaks:
  - Around the gasket.
  - Behind the barrel.
  - The tip of the barrel.
3. If plastic nozzle is found defective, dispose (NFES #000137, #000138).

### C. Refurbishing Procedures

Replace tip, screw, and O-ring, if needed (NFES #001081, #001082).

### D. Retesting Criteria

Retest according to B. Tests.

### E. Cleaning Procedures

1. All items will be washed and cleaned of foreign matter, such as mud, dirt, and grease. Clean in a mild detergent with brush and scouring pad, or high pressure wash as needed. Do not soak for extended periods of time or the detergent will corrode the metal.
2. Rinse thoroughly.
3. Stand upright with barrel in open position to drain water and dry.
4. Lubricate threads on back of the barrel with appropriate dry lubricant (graphite).

### F. Repackaging

- Use carton 10" X 8" X 6" (NSN 8115-00-183-9497) for each of the following:
  - NFES #001081 STANDARD PACK 20 per carton
  - NFES #000137 STANDARD PACK 10 per carton
  - NFES #000138 STANDARD PACK 10 per carton
- Use carton 16" x 10" x 6" -- NFES #001082 STANDARD PACK 20 per carton

### G. Storage and Shelf Life Checks -- none

### H. Reference

Water Handling Equipment Guide, NWCG PMS 447-1  
<http://www.nwcg.gov/pms/pubs/WHEG03.pdf>

## Fire Equipment Storage and Refurbishing Standards

---

ITEM: **NOZZLE**, plastic, fire foam, 8 GPM, 16 GPM, 30 GPM      NFES #000627, #000628, #000629

**A. Initial Inspection Disposal Criteria**

1. Inspect for worn or damaged threads, repair or replace.
2. Inspect for gasket, replace if missing.
3. Ensure nozzle barrel has no cracks in plastic, if cracked dispose of.

**B. Tests -- none**

**C. Refurbishing Procedures**

Replace gasket if necessary.

**D. Retesting Criteria -- none**

**E. Cleaning Procedures**

1. Wash and clean of foreign matter, such as mud, dirt, and grease.
2. Clean with scrub brush in water with dishwashing detergent or high pressure wash.
3. Rinse thoroughly.
4. Stand upright and allow to dry.

**F. Repackaging**

Local cache option.

**G. Storage and Shelf Life Checks -- none**

**H. Reference**

Water Handling Equipment Guide, NWCG PMS 447-1

<http://www.nwcg.gov/pms/pubs/WHEG03.pdf>

ITEM: **NOZZLE**, garden hose 3/4"

NFES #000136

**A. Initial Inspection/Disposal Criteria**

1. Inspect for burrs.
2. Inspect gasket if damaged or missing replace.
3. Inspect for bad threads.  
If 1 or 3 exists dispose of by recycling the brass.

**B. Test**

Test at 100 PSI. If nozzle leaks, dispose of by recycling the brass.

**C. Refurbishing Procedures**

Replace missing or cracked gaskets.

**D. Retesting Procedures -- none**

**E. Cleaning Procedures**

1. Wash and clean of mud, dirt, and grease.
2. Clean in a mild detergent with brush or scouring pad or high-pressure wash.
3. Rinse thoroughly.
4. Stand upright to drain water and dry.

**F. Repackaging**

Local cache option

STANDARD PACK is 10 each per carton or 100 each per carton.

**G. Storage and Shelf Life Checks -- none**

**H. Recycle as local cache options are available**

Recycle brass parts

## Fire Equipment Storage and Refurbishing Standards

---

ITEM: **NOZZLE**, twin tip, combination, 1” NPSH-F

NFES #000024

**A. Initial Inspection/Disposal Criteria**

1. Inspect for obvious damage, cracks, and large burrs, if so dispose of.
2. Inspect for gasket and screen, if missing replace.
3. Inspect handle for damage or missing screw.
  - Is handle in right position? Does handle turn freely in proper position?
4. Inspect for fire damage: may cause failure in the future.
5. Inspect hose coupling threads for damage.

**B. Tests**

1. Install nozzle on pump.
2. Open handle on nozzle.
3. Turn on water.
4. Inspect pattern on fog-tip to see if clogged—CLEAN OUT.
5. Close handle.
6. Turn on pump to 300 PSI.
7. Inspect for leaks:
  - Gasket.
  - Under the handle.
  - At both tips.

**C. Refurbishing Procedures**

1. Replace handle and ball with a new kit if needed.
2. Replace tail gasket and/or screen if missing, cracked, or stiff.  
Nozzle will have a 3/16” straight-stream tip (NFES #000637) and a 2—4 gal/min fog tip (NFES #000635).

**D. Retesting Criteria--See B. Tests.**

**E. Cleaning Procedures**

1. Clean in a dishwashing detergent with brush, scouring pad or high-pressure wash as needed.  
Do not soak for extended periods of time or the detergent will corrode the metal.
2. Rinse thoroughly, stand upright with handle in open position and allow to dry.
3. Lubricate with appropriate dry lubricant such as graphite.

**F. Repackaging**

Package in units containing nozzle body with a 3/16” straight-stream tip and 2—4 gal/min fog tip.  
Package 20 each in carton 12” X 9” X 10” (NSN 8115-01-012-5504).

**G. Storage and Shelf Life Checks -- none**

**I. Reference**

Water Handling Equipment Guide, NWCG PMS 447-1  
<http://www.nwcg.gov/pms/pubs/WHEG03.pdf>

**J. Recycle as local cache options are available.**

## Fire Equipment Storage and Refurbishing Standards

---

ITEM: <b>PACK</b> , fireline, blue, complete (w/canteen case and stuff sack)	NFES #000674
<b>PACK</b> , field, firefighter, unisex, complete	NFES #001372
<b>PACK</b> , personal gear	NFES #001855
<b>PACKSACK</b> , waterproof, w/straps	NFES #000744

### A. Initial Inspection/Disposal Criteria

#### ✓ **Dispose of item if beyond economical repair.**

1. Inspect fabric for cuts, tears, burns and areas of abrasion.
2. Inspect seams for breaks in stitching and for areas where the fabric is unraveling into the seams.
3. Inspect all straps and webbing for cuts or excessive wear. Ensure they're securely attached to the fabric.
4. Inspect all zippers for broken coils, missing or broken sliders. Ensure they're securely attached to the fabric. Open and close the zippers to ensure a smooth and proper function.
5. Ensure all hardware, buckles and Velcro closures are correctly attached.
  - a. Inspect all buckles and hardware for cracks or breaks. Fasten and unfasten all buckles and hardware to ensure a smooth and proper function.
  - b. Ensure all Velcro closures are securely attached.
6. Dispose of the item if there's any indelible writing or markings on the item.

### B. Tests -- none

### C. Refurbishing Procedures

1. If necessary, replace buckles and hardware.
2. Repair any tears, holes or areas of excessive abrasion if economically feasible.
3. Repair any seams that are worn or that have torn loose.
4. Repair or replace webbing.

### D. Retesting Criteria -- none

### E. Cleaning Procedures

✓ **DO NOT MACHINE WASH OR DRY FOR NFES #000674, #001372, #001855.**

✓ **DO NOT USE BLEACH TO CLEAN FABRIC.**

✓ **MACHINE WASH OK FOR NFES# 000744**

1. Allow any mud and loose dirt to dry, and then remove with a stiff brush.
2. Remove light oil stains using a solution of warm water and mild detergent and a brush.
3. Rinse with clean water, hang to dry.
4. Remove heavy stains by soaking (as long as needed) in water-soluble biodegradable cleaner. After soaking, wash with a hot water pressure washer and rinse with warm clean water. Hang to dry.

### F. Repackaging

1. Insert 2 blue canteen case and blue stuff sack into main compartment. Close all buckles, secure the shoulder yoke. Pack 10 packs per box.
2. For NFES #001372, insert 2 canteen cases and 1 belt pack into main compartment. Close all buckles and secure the shoulder straps. Pack 10 packs per box.
3. For NFES #001855, store 10 packs in a carton 18" X 14" X 18".
4. For NFES #000744, pack to local cache option.

### G. Storage and Shelf Life Checks -- none

---

## Fire Equipment Storage and Refurbishing Standards

---

ITEM: **PAD**, sleeping, gray, 3/8" X 23" X 75", foam

NFES #001566

**A. Initial Inspection/Disposal Criteria**

1. Inspect for any cuts, splits, tears, holes or cracks, if so dispose of.
2. Inspect for uniformity; if it contains, large voids or inclusions, dispose of.
3. Inspect for cleanliness or the presence of foreign matter, if so dispose of.
4. Dampness--see E. Cleaning Procedures.

**B. Tests -- none**

**C. Refurbishing Procedures**

See E. Cleaning Procedures.

**D. Retesting Criteria -- none**

**E. Cleaning Procedures**

1. If pad is wet, expose to sun or other heat source until dry.
2. Brush with stiff-bristle brush to eliminate dirt or other foreign matter.
3. Blow off remaining dust or fine dirt particles with high-pressure air hose or vacuum.
4. Disinfect with mild detergent and air dry.

**F. Repackaging**

Repack 50 each in original carton (if serviceable) or use NFES #000134 carton (76" X 22" X 20") (NSN 8115-01-381-6529).

**G. Storage and Shelf Life Checks -- none**

**H. Recycle as local cache options are available.**

## Fire Equipment Storage and Refurbishing Standards

---

ITEM: **POLE**, ridge, 16'

NFES #000089

- A. Initial Inspection/Disposal Criteria**  
Visually inspect for damage, bent pole—dispose of damaged pieces (salvage usable parts).
- B. Tests -- none**
- C. Refurbishing Procedures**  
Replace missing or damaged parts.
- D. Retesting Criteria -- none**
- E. Cleaning Procedures**  
Completed in C. Refurbishing Procedures.
- F. Repackaging**  
Package in carton NFES #008202.
- G. Storage and Shelf Life Checks -- none**

ITEM: **POLE**, upright, adjustable

NFES# 000083

**A. Initial Inspection/Disposal Criteria**

Visually inspect for damage, bent pole—dispose of damaged pieces (salvage usable parts).

**B. Tests**

Extend pole to see if pole telescopes freely.

**C. Refurbishing Procedures**

If top pin is bent or broken, replace with a steel pin.

Replace adjuster pins and cables when missing.

**D. Retesting Criteria -- none**

**E. Cleaning Procedures**

Remove all foreign material.

Clean with damp cloth.

**F. Repackaging**

Package 6 each in carton NFES #008202.

**G. Storage and Shelf Life Checks -- none**



## Fire Equipment Storage and Refurbishing Standards

---

ITEM: **PULASKI**, with plastic sheath

NFES #000146

### A. Initial Inspection/Disposal Criteria

1. Obvious structural damage to cutting edges or head.
2. Dispose of tool if modifications have been made to head, such as rivets through side of head to hold handle.

### B. Tests/Inspections

1. Head.
  - a. Head is within specifications as per gauge (NFES# 000510).
  - b. Grubbing end is not bent or twisted.
  - c. Blade or grubbing hoe ends have not been tapered or rounded to point the tool cannot be sharpened to meet gauge standards.
2. Handle replacement.
  - a. Twisted, bent, or open grain.
  - b. Cracks, or suspect based on sound of hammer rap on end of handle (sharp ringing sound is good; dull thud sound is suspect), or pressure application to side of handle.
3. Head is loose and/or contains metal wedges.
4. Handle has been shortened.
5. Nonstandard handle.

### C. Refurbishing Procedures

1. Head.
    - a. Clean head.
    - b. Sharpen tool to specifications as per tool sharpening gauge NFES #000510.
    - c. Ensure that blade corners are square.
  - ✓ **CAUTION: Tool should NEVER be ground to the degree that the metal temperature raises high enough to remove temper, i.e., blue or burned edges.**
  2. Used handles.
    - a. Clean handle.
    - b. Sand handle if it is chipped, dinged, rough, or has tape or other residues.
  3. New handles.
    - a. Local replacement-utilize NFES #001857 handle with plastic wedge or wood wedges secured using epoxy of appropriate type.
- ✓ **Metal wedges can be added only in the field as an emergency measure for field refurbishing.**

### D. Retesting Criteria -- none

### E. Cleaning Procedures--See C. Refurbishing Procedures

### F. Repackaging

1. Install plastic sheath NFES #000257.
2. Package 10 each in carton NFES #000338; 37" X 18" X 8" (NSN 8115-00-139-0673). Full depth carton top.

### G. Storage and Shelf Life Checks

Per local cache requirements to ensure proper serviceability of tool.  
Excessively dry storage may cause handles to loosen.

### H. Reference--[New and Improved Flap Cup Grinder Disc](#)

ITEM: **PULLER**, fence

NFES #000011

**A. Initial Inspection/Disposal Criteria**

Inspect visually for broken, used or missing parts.

Inspect for structural damage, bent upright or handle, if so dispose of. Salvage usable parts.

**B. Tests -- none**

**C. Refurbishing Procedures**

1. Clean if necessary.

2. Replace bolts or pins if bent or broken.

3. Repaint if necessary to prevent rust or corrosion.

**D. Retesting Criteria**

Inspect to see that all parts function correctly once refurbishing is complete.

**E. Cleaning Procedures**

See C. Refurbishing Procedures.

**F. Repackaging -- none**

**G. Storage and Shelf Life Checks -- none**

## Fire Equipment Storage and Refurbishing Standards

---

ITEM: **PUMP**, fire, lightweight, 2 cycle

NFES #000124, #000253

### A. Initial Inspection/Disposal Criteria

- ✓ NOTE: Follow the manufacturer's safety precautions as listed in the owner's manual prior to operation of this item.
- ✓ If unit is not economically repairable it should be disposed of using local agency policy.
  1. Visually inspect for evidence of use (dust, oil, starter seal broken), damage or missing parts.
  2. Return to stock if: there is no sign of use or damage and date last tested (DLT) does not exceed 12 months.
  3. Refurbish as necessary if unit has been used, damaged, or shelf life is exceeded.

### B. Tests

- ✓ NOTE: Refer to the owner's manual for operations and specifications information specific to pump model.
- ✓ Check condition of fuel mix. Ensure fuel is fresh and the correct mix oil ratio is used for running tests (see G. Storage and Shelf Life Checks.)
  1. Test function of rewind starter, ensure proper engagement of engine and recoil functionality. Check for damage or fraying of pull cord; repair or replace as necessary.
  2. Engine should: start easily, run smoothly, be free from fuel leaks, and provide sufficient power to the pump end.
  3. Ensure engine operational controls are functioning properly: stop switch, throttle and choke.
  4. Test for pump performance (see owner's manual for specific performance data).
  5. Ensure pump seal is not leaking, repair or replace as necessary.

### C. Refurbishing Procedures

- ✓ NOTE: If this equipment is taken to a "factory authorized" repair facility for refurbishment; ensure that they receive a copy of this refurbishment standard. The repair facility must satisfy both the requirements as set by the manufacturer specification and the agreement made with the local agency.
  1. Clean unit as necessary (see E. Cleaning Procedures.)
  2. Check for oil/fuel leaks prior to washing.
  3. Check for loose and/or missing parts or mounting hardware; tighten or replace as needed.
  4. Check condition of spark plug, air filter, and fuel filter; clean or replace as needed.
  5. Inspect exhaust system; make sure there are no cracks or leaks. Clean spark arrestor of excess carbon build up, replace screen if damaged.
  6. Ensure all decals (operations and warning) are affixed and legible.
  7. Check to make sure that all gaskets on the pump fittings/adapters are in place and functioning properly.
  8. Test for performance (see B. Tests.) Should any function fail a test, refer to the manufacturers' repair manual/s and troubleshooting guide to correct the problem.
  9. Remove all gasoline from fuel tank and fuel line. Run engine until carburetor is completely empty of gas (use choke).
  10. Remove all water from pump end. Grease pump as necessary.
  11. Prepare unit for storage (see F. Repackaging.)

Continued --

ITEM: **PUMP**, fire, lightweight, 2 cycle

NFES #000124, #000253

**D. Retesting Criteria**

1. Retest if date last tested (DLT) is exceeded or starter seal is broken.
2. Ensure C. Refurbishing Procedures are completed.

**E. Cleaning Procedures**

1. Remove dirt, oil and grease, using detergent or degreaser as necessary (use pressure washer to remove heavy soil).
2. Use pressure washer only if you will start and run the pump the same day.

**F. Repackaging**

1. Use nylon “zip-tie” to tie off (seal) starter rope to carry handle, to later determine if equipment has been used.
2. Attach certification tag; that indicates date last tested (DLT), property #, and name of individual certifying performance.
3. Ensure that all identification (property #, serial #, owner ID) is affixed and legible.
4. Ensure that the pump head is drained of water.

**G. Storage and Shelf Life Checks**

1. Recommendation: Use a fuel stabilizer in fuel during testing to help ensure proper operation of engine at post storage start up.
2. Ensure that date last tested (DLT) does not exceed 12 months.

**H. References**

[www.wildfire-equipment.com](http://www.wildfire-equipment.com)  
[www.hondapowerequipment.com](http://www.hondapowerequipment.com)  
[www.shindaiwa.com](http://www.shindaiwa.com)  
[www.mercedestextiles.com](http://www.mercedestextiles.com),

---

## Fire Equipment Storage and Refurbishing Standards

---

ITEM: **PUMP**, fire, lightweight, 4 cycle

NFES #006000

### A. Initial Inspection/Disposal Criteria

- ✓ NOTE: Follow the manufacturer's safety precautions as listed in the owner's manual prior to operation of this item.
- ✓ If unit is not economically repairable it should be disposed of using local agency policy.
  1. Visually inspect for evidence of use (dust, oil, starter seal broken), damage or missing parts.
  2. Return to stock if: there is no sign of use or damage and date last tested (DLT) does not exceed 12 months.
  3. Refurbish as necessary if unit has been used, damaged, or shelf life is exceeded.

### B. Tests

- ✓ NOTE: Refer to the owners' manual for operations and specifications information specific to pump model.
- ✓ Check condition of fuel and engine oil; ensure fuel is fresh and the oil level is sufficient for running tests (see G. Storage and Shelf Life Checks.)
  1. Test function of rewind starter, ensure proper engagement of engine and recoil functionality. Check for damage or fraying of pull cord; repair or replace as necessary.
  2. Engine should: start easily, run smoothly, be free from leaks (oil/fuel), and provide sufficient power to the pump end. Ensure engine operational controls are functioning properly; stop switch, throttle and choke.
  3. Test for pump performance (see owner's manual for specific performance data).
  4. Ensure pump seal is not leaking, repair or replace as necessary.

### C. Refurbishing Procedures

- ✓ NOTE: If this equipment is taken to a "factory authorized" repair facility for refurbishment; ensure that they receive a copy of this refurbishment standard. The repair facility must satisfy both the requirements as set by the manufacturers' specification and the agreement made with the local agency.
  1. Clean unit as necessary (see E. Cleaning Procedures.)
  2. Check for oil/fuel leaks prior to washing.
  3. Check for loose and/or missing parts or mounting hardware; tighten or replace as needed.
  4. Check condition of engine oil, spark plug, air filter, and fuel filter; clean or replace as needed.
  5. Inspect exhaust system; make sure there are no cracks or leaks.
  6. Clean spark arrestor of excess carbon build up, replace screen if damaged.
  7. Ensure all decals (operations and warning) are affixed and legible.
  8. Check to make sure that all gaskets on the pump fittings/adapters are in place and functioning properly.
  9. Test for performance (see B. Tests.) Should any function fail a test, refer to the manufacturers' repair manual/s and troubleshooting guide to correct the problem.
  10. Remove all gasoline from fuel tank and fuel line. Run engine until carburetor is completely empty of gas (use choke).
  11. Remove all water from pump end.
  12. Prepare unit for storage (see F. Repackaging.)

Continued --

ITEM: **PUMP**, fire, lightweight, 4 cycle

NFES #006000

**D. Retesting Criteria**

1. Retest if date last tested (DLT) is exceeded or starter seal is broken.
2. Ensure C. Refurbishing Procedures are completed.

**E. Cleaning Procedures**

1. Remove dirt, oil and grease, using detergent or degreaser as necessary.
2. Use pressure washer to remove heavy soil.
3. Use pressure washer only if you will start and run the pump the same day.

**F. Repackaging**

1. Use nylon “zip-tie” to tie off (seal) starter rope to carry handle, to later determine if equipment has been used.
2. Attach certification tag; that indicates date last tested (DLT), property #, and name of individual certifying performance.
3. Ensure that all identification (property #, serial #, owner ID) is affixed and legible.
4. Ensure that the pump head is drained of water.

**G. Storage and Shelf Life Checks**

✓ **Recommendation:** Use a fuel stabilizer in fuel during testing to help ensure proper operation of engine at post storage start up.

Ensure that date last tested (DLT) does not exceed 12 months.

**H. References**

- [www.wildfire-equipment.com](http://www.wildfire-equipment.com)
- [www.hondapowerequipment.com](http://www.hondapowerequipment.com)
- [www.mercedestextiles.com](http://www.mercedestextiles.com)

## Fire Equipment Storage and Refurbishing Standards

ITEM: **PUMP**, fire, portable, high pressure w/fuel line

NFES #000148

### A. Initial Inspection/Disposal Criteria

- ✓ NOTE: Follow the manufacturer's safety precautions as listed in the owner's manual prior to operation of this item
- ✓ If unit is not economically repairable it should be disposed of using local agency policy.
  1. Visually inspect for evidence of use (dust, oil, starter seal broken), damage or missing parts.
  2. Return to stock if: there is no sign of use or damage and date last tested (DLT) does not exceed 12 months.
  3. Refurbish as necessary if unit has been used, damaged, or shelf life is exceeded.

### B. Tests

- ✓ NOTE: Refer to the owner's manual for operations and specifications information specific to pump model.
- ✓ Check condition of fuel mix; ensure fuel is fresh and the correct mix oil ratio is used for running tests (see G. Storage and Shelf Life.)

Pumps are tested using: 1½" suction hose at pump intake and 31/64" discharge (machined square edge orifice). The use of a full bore 1½" shut-off valve will be necessary to test for maximum pump output pressure. Grade 1A liquid filled pressure gauges with 5 PSI graduation are recommended.

Table 1 and Table 2 reflect minimum output pressures for refurbishing high pressure pumps as a function of elevation. A one foot lift should be used as a standard drafting height.

Table 1. MARK 3 Pump, minimum output

Elevation (ft)	Shut-off pressure <sup>1</sup> (PSI)	Working pressure @ 31/64" orifice <sup>2</sup> (PSI)
0	295	135
1000	280	135
2000	270	130
3000	255	130
4000	245	125
5000	230	125
6000	215	120

Table 2. Wick 375 Pump, minimum output

Elevation (ft)	Shut-off pressure <sup>3</sup> (PSI)	Working pressure @ 31/64" orifice <sup>4</sup> (PSI)
0	335	150
1000	320	145
2000	305	140
3000	295	135
4000	280	130
5000	265	125
6000	250	120

<sup>1</sup> Based on the formula, Pressure = -0.0129 \* (Elevation) + 294.24

<sup>2</sup> Based on the formula, Pressure = -0.0026 \* (Elevation) + 135.27

<sup>3</sup> Based on the formula, Pressure = -0.0138 \* (Elevation) + 334.7

<sup>4</sup> Based on the formula, Pressure = -0.0044 \* (Elevation) + 148.75

1. Start pump and allow engine to warm up for two minutes.
2. Ensure pump seal is free from leaks. Pump shaft bearing should turn smoothly and be adequately greased.
3. Ensure idle speed and low speed mixture screw are properly adjusted.

Continued --

ITEM: **PUMP**, fire, portable, high pressure w/fuel line

NFES #000148

4. Using full throttle: set high speed adjustment by turning high speed mixture screw to achieve maximum engine RPM and then richen mixture screw until there is a drop in pump output pressure of 5-10 PSI (approx.).
  - Engine should be responsive and accelerate quickly.
5. Perform shut-off pressure test at full throttle; note maximum pressure at full discharge shut-off, ensuring pump output meets minimum standards as outlined in table 1 or 2 (above) depending on pump model.
6. Perform pressure test with the 31/64" square edge orifice at full throttle; note working flow pressure, ensuring pump output meets minimum standards as outlined in table 1 or 2 (above) depending on pump model.
7. Use loss of prime method to test over-speed protection cut-out switch, adjust as necessary to manufacturer specification.
8. Should any function fail a test, refer to the manufacturers' repair manual and troubleshooting guide to correct the problem.
9. Allow engine to cool down for one minute at idle.
  - Remove fuel source and run carburetor completely out of fuel. Use choke.
10. Remove all water from pump end. Grease pump as necessary.

### **C. Refurbishing Procedures**

1. Clean unit as necessary (see E. Cleaning Procedures.)
  - Check for oil/fuel leaks prior to washing.
2. Check for loose and/or missing parts or mounting hardware; tighten or replace as needed.
3. Inspect power-head (engine) for freeness of all moving parts, ensuring that the crankshaft, piston/cylinder and all engine bearings are not damaged.
4. Check condition of spark plug, air filter, and fuel filter; clean or replace as needed.
  - Re-oil foam air filter.
5. Inspect exhaust system; make sure there are no cracks or leaks.
  - Clean spark arrestor of excess carbon build up, replace screen if damaged.
6. Ensure all decals (operations and warning) are affixed and legible.
7. Paint exposed metal on frame, cowling, and pump body.
8. Test for performance (see B. Tests.)  
Should any function fail a test, refer to the manufacturers' repair manual and troubleshooting guide to correct the problem.
9. Check to make sure that all gaskets on the pump fittings/adapters are in place and functioning properly.
10. Inspect: NFES# 000113, Fuel Line Assembly. Check for cracks, cuts or other defects to fuel hose, priming bulb or fuel tank fitting (O-rings). Repair or replace as necessary.
  - Replace priming bulb if it cannot be easily squeezed.
11. Prepare unit for storage (see F. Repackaging.)

### **D. Retesting Criteria**

1. Retest if date last tested (DLT) is exceeded or starter seal is broken.
2. Ensure C. Refurbishing Procedures are completed.



Continued --

ITEM: **PUMP**, fire, portable, high pressure w/fuel line

NFES #000148

**E. Cleaning Procedures**

1. Remove dirt, oil and grease, using detergent or degreaser as necessary. Use pressure washer to remove heavy soil.
2. Use pressure washer only if you will start and run the pump the same day.

**F. Repackaging**

1. Use nylon “zip-tie” to tie off (seal) starter rope to frame, to later determine if equipment has been used.
2. Attach certification tag; that indicates; pump output pressure, date last tested (DLT), property #, and name of individual certifying performance.
3. Ensure that all identification (property #, serial #, owner ID) is affixed and legible.
4. Ensure that the pump head is drained of water.

**G. Storage and Shelf Life Checks**

- ✓ Recommendation: Use a fuel stabilizer in fuel during testing to help ensure proper operation of engine at post storage start up.

Ensure date last tested (DLT) does not exceed 12 months.

**H. Reference**

[www.wildfire-equipment.com](http://www.wildfire-equipment.com)

[www.mercedestextiles.com](http://www.mercedestextiles.com),

ITEM: **PUMP**, 1½” floating, waterous

NFES #007646

**A. Initial Inspection/Disposal Criteria**

- ✓ NOTE: Follow the manufacturer’s safety precautions as listed in the owner’s manual prior to operation of this item.
- ✓ If unit is not economically repairable it should be disposed of using local agency policy.
  1. Visually inspect for evidence of use (dust, oil, starter seal broken), damage or missing parts.
  2. Return to stock if: there is no sign of use or damage and date last tested (DLT) does not exceed 12 months.
  3. Refurbish as necessary if unit has been used, damaged, or shelf life is exceeded.

**B. Tests**

- ✓ NOTE: Refer to the owners’ manual for operations and specifications information specific to pump model.
- ✓ Check condition of fuel mix; ensure fuel is fresh and the correct mix oil ratio (24:1) is used for running tests (see G. Storage and Shelf Life.)
  1. Test function of rewind starter, ensure proper engagement of engine and recoil functionality.
    - Check for damage or fraying of pull cord; repair or replace as necessary.
  2. Engine should: start easily, run smoothly, be free from fuel leaks, and provide sufficient power to the pump end.
    - Ensure engine operational controls are functioning properly; stop switch, throttle and choke.
  3. Test for pump performance:
    - a. Place pump unit in clean water source.
    - b. Pumps are tested using a 1½” discharge with a ¼” nozzle.
  4. Adjust carburetor:
    - a. Set idle speed to 2400 RPM (manually hold throttle float down).
    - b. To adjust high speed: using full throttle, lean out high speed adjustment screw to achieve max RPM, then richen until pump output pressure drops 5 PSI. Minimum pressure: 100 PSI

**C. Refurbishing Procedures**

1. Clean unit as necessary (see E. Cleaning Procedures.)
  - Check for oil/fuel leaks prior to washing.
2. Check for loose and/or missing parts or mounting hardware; tighten or replace as needed.
3. Check condition of spark plug, air filter, and fuel filter; clean or replace as needed.
4. Inspect exhaust system; make sure there are no cracks or leaks.
  - Check for loose and/or missing parts (especially the muffler) or mounting hardware; tighten or replace as needed.
5. Check throttle float.
  - Make sure all pieces are present and that the float moves up and down freely.
6. Make sure that there are no holes in the boat.
7. Check water intake for debris (weeds, sticks, etc.).
  - Make sure the screen is in place and securely fastened.
8. Ensure all decals (operations and warning) are affixed and legible.
9. Test for performance (see B. Tests.)

## Fire Equipment Storage and Refurbishing Standards

---

Continued --

ITEM: **PUMP**, 1½" floating, waterous

NFES #007646

10. Remove all fuel from fuel tank and fuel line.
  - Run engine until carburetor is completely empty of gas (use choke).
11. Prepare unit for storage (see F. Repackaging.)

### **D. Retesting Criteria**

1. Retest if date last tested (DLT) is exceeded or starter seal is broken.
2. Ensure C. Refurbishing Procedures are completed.

### **E. Cleaning Procedures**

1. Remove dirt, oil and grease, using detergent or degreaser as necessary (use pressure washer to remove heavy soil).
2. Use pressure washer only if you will start and run the pump the same day.

### **F. Repackaging**

1. Use nylon "zip-tie" to tie off (seal) starter rope to carry handle, to later determine if equipment has been used.
2. Attach certification tag; that indicates; pump output pressure, date last tested (DLT), property #, and name of individual certifying performance.
3. Ensure that all identification (property #, serial #, owner ID) is affixed and legible.
4. Ensure that the pump head is drained of water.

### **G. Storage and Shelf Life Checks**

✓ Recommendation: Use a fuel stabilizer in fuel during testing to help ensure proper operation of engine at post storage start up.

Ensure that date last tested (DLT) does not exceed 12 months.

### **H. References**

[www.waterousco.com](http://www.waterousco.com)

[www.usmotorpower.com](http://www.usmotorpower.com),

---

## Fire Equipment Storage and Refurbishing Standards

---

ITEM: **PUMP**, 1½” Multiquip, 5.5 HP

NFES #007647

### A. Initial Inspection/Disposal Criteria

- ✓ NOTE: Follow the manufacturer’s safety precautions as listed in the owner’s manual prior to operation of this item.
- ✓ If unit is not economically repairable it should be disposed of using local agency policy.
  1. Visually inspect for evidence of use (dust, oil, starter seal broken), damage or missing parts.
  2. Return to stock if: there is no sign of use or damage and date last tested (DLT) does not exceed 12 months.
  3. Refurbish as necessary if unit has been used, damaged, or shelf life is exceeded.

### B. Tests

- ✓ NOTE: Refer to the owners’ manual for operations and specifications information specific to pump model.
- ✓ Check condition of fuel and engine oil; ensure fuel is fresh and the oil level is sufficient for running tests (see G. Storage and Shelf Life)
  1. Test function of rewind starter, ensure proper engagement of engine and recoil functionality.
    - Check for damage or fraying of pull cord; repair or replace as necessary.
  2. Engine should: start easily, run smoothly, be free from fuel leaks, and provide sufficient power to the pump end.
    - Ensure engine operational controls are functioning properly; stop switch, throttle and choke.
  3. Test for pump performance:
    - Adjust carburetor:
      - Set idle speed to 1200 RPM.
      - Maximum engine speed 3500 RPM.
      - Check max PSI with nozzle closed. Minimum pressure: 50 PSI
  4. Ensure pump seal is not leaking. Repair or replace as necessary.

### C. Refurbishing Procedures

1. Clean unit as necessary (see E. Cleaning Procedures.)
  - Check for oil/fuel leaks prior to washing.
2. Check for loose and/or missing parts or mounting hardware; tighten or replace as needed.
3. Check condition of engine oil, spark plug, air filter, and fuel filter.
  - Clean or replace as needed.
4. Inspect exhaust system; make sure there are no cracks or leaks.
  - Check for loose and/or missing parts or mounting hardware.
  - Tighten or replace as needed.
5. Ensure all decals (operations and warning) are affixed and legible.
6. Check to make sure that all gaskets on the pump fittings/adapters are in place and functioning properly.
7. Test for performance (see B. Tests.)
8. Remove fuel from fuel tank and fuel line.
  - Run engine until carburetor is completely empty of gas (use choke).
9. Prepare unit for storage (see F. Repackaging.)

Continued --

ITEM: **PUMP**, 1½” Multiquip, 5.5 HP

NFES #007647

**D. Retesting Criteria**

1. Retest if date last tested (DLT) is exceeded or starter seal is broken.
2. Ensure C. Refurbishing Procedures are completed.

**E. Cleaning Procedures**

1. Remove dirt, oil and grease, using detergent or degreaser as necessary.  
Use pressure washer to remove heavy soil.
2. Use pressure washer only if you will start and run the pump the same day.

**F. Repackaging**

1. Use nylon “zip-tie” to tie off (seal) starter rope to handle bar, to later determine if equipment has been used.
2. Attach certification tag; that indicates; pump output pressure, date last tested (DLT), property #, and name of individual certifying performance.
3. Ensure that all identification (property #, serial #, owner ID) is affixed and legible.
4. Ensure that the pump head is drained of water.

**G. Storage and Shelf Life Checks**

- ✓ **Recommendation:** Use a fuel stabilizer in fuel during testing to help ensure proper operation of engine at post storage start up.

Ensure that date last tested (DLT) does not exceed 12 months.

**H. References**

- [www.multiquip.com](http://www.multiquip.com)
- [www.hondapowerequipment.com](http://www.hondapowerequipment.com)
- [www.robinamerica.com](http://www.robinamerica.com)

ITEM: **PUMP**, 2½", 6.5---13HP, centrifugal

NFES #007648

**A. Initial Inspection/Disposal Criteria**

- ✓ NOTE: Follow the manufacturer's safety precautions as listed in the owner's manual prior to operation of this item.
- ✓ If unit is not economically repairable it should be disposed of using local agency policy.
  1. Visually inspect for evidence of use (dust, oil, starter seal broken), damage or missing parts.
  2. Return to stock if: there is no sign of use or damage and date last tested (DLT) does not exceed 12 months.
  3. Refurbish as necessary if unit has been used, damaged, or shelf life is exceeded.

**B. Tests**

- ✓ NOTE: Refer to the owners' manual for operations and specifications information specific to pump model.
- ✓ Check condition of fuel and engine oil; ensure fuel is fresh and the oil level is sufficient for running tests (see G. Storage and Shelf Life Checks.)
  1. Test function of rewind starter, ensure proper engagement of engine and recoil functionality.
  2. Check for damage or fraying of pull cord; repair or replace as necessary.
  3. Engine should: start easily, run smoothly, be free from fuel leaks, and provide sufficient power to the pump end.
  4. Ensure engine operational controls are functioning properly: stop switch, throttle and choke.
  5. Test for pump performance:
    - Adjust carburetor:
      - Set idle speed to 1200 RPM.
      - Maximum engine speed 3500 RPM.
      - Governor spring should be in the 1<sup>st</sup> or 2<sup>nd</sup> hole on the throttle side.
    - Check max PSI with nozzle closed. Minimum pressure: 70 PSI
  6. Ensure pump seal is not leaking, repair or replace as necessary.

**C. Refurbishing Procedures**

1. Clean unit as necessary (see E. Cleaning Procedures.)
2. Check for oil/fuel leaks prior to washing.
3. Check for loose and/or missing parts or mounting hardware; tighten or replace as needed.
4. Check condition of engine oil, spark plug, air filter, and fuel filter; clean or replace as needed.
5. Inspect exhaust system; make sure there are no cracks or leaks.
6. Check for loose and/or missing parts or mounting hardware; tighten or replace as needed.
7. Check to make sure that all gaskets on the pump fittings/adapters are in place and functioning properly.
8. Ensure all decals (operations and warning) are affixed and legible.
9. Test for performance (see B. Tests.)
10. Remove all fuel from fuel tank and fuel line.
11. Run engine until carburetor is completely empty of gas (use choke).
12. Prepare unit for storage (see F. Repackaging.)

Continued --

ITEM: **PUMP**, 2½", 6.5---13HP, centrifugal

NFES #007648

**D. Retesting Criteria**

1. Retest if date last tested (DLT) is exceeded or starter seal is broken.
2. Ensure C. Refurbishing Procedures are completed.

**E. Cleaning Procedures**

1. Remove dirt, oil and grease, using detergent or degreaser as necessary.
  - Use pressure washer to remove heavy soil.
2. Remove front of pump housing and steam clean inside.
  - Check O-ring seal and replace if necessary.
3. Use pressure washer only if you will start and run the pump the same day.

**F. Repackaging**

1. Use nylon "zip-tie" to tie off (seal) starter rope to frame, to later determine if equipment has been used.
2. Attach certification tag; that indicates; pump output pressure, date last tested (DLT), property #, and name of individual certifying performance.
3. Ensure that all identification (property #, serial #, owner ID) is affixed and legible.
4. Ensure that the pump head is drained of water.

**G. Storage and Shelf Life Checks**

- ✓ **Recommendation:** Use a fuel stabilizer in fuel during testing to help ensure proper operation of engine at post storage start up.

Ensure that date last tested (DLT) does not exceed 12 months.

**H. References**

[www.multiquip.com](http://www.multiquip.com)

[www.robinamerica.com](http://www.robinamerica.com)

ITEM: **PUMP**, portable, Wick-250

NFES #007650

**A. Initial Inspection/Disposal Criteria**

- ✓ NOTE: Follow the manufacturer's safety precautions as listed in the owner's manual prior to operation of this item.
- ✓ If unit is not economically repairable it should be disposed of using local agency policy.
  1. Visually inspect for evidence of use (dust, oil, starter seal broken), damage or missing parts.
  2. Return to stock if: there is no sign of use or damage and date last tested (DLT) does not exceed 12 months.
  3. Refurbish as necessary if unit has been used, damaged, or shelf life is exceeded.

**B. Tests**

- ✓ NOTE: Refer to the owner's manual for operations and specifications information specific to pump model.
- ✓ Check condition of fuel mix; ensure fuel is fresh and the correct mix oil ratio (24:1) is used for running tests (see G. Storage and Shelf Life Checks.)
  1. Test function of rewind starter, ensure proper engagement of engine and recoil functionality. Check for damage or fraying of pull cord; repair or replace as necessary.
  2. Engine should: start easily, run smoothly, be free from fuel leaks, and provide sufficient power to the pump end.
  3. Ensure engine operational controls are functioning properly; stop switch, throttle and choke.
  4. Test for pump performance:
    - a. Pumps are tested with 1½" inlet w/foot valve and 1½" discharge with a ¼" nozzle.
    - b. Adjust carburetor:
      - Set idle speed to 2400 RPM.
      - To adjust high speed: use full throttle and set pump output pressure to 120 PSI. Lean out adjustment screw to achieve max RPM, then richen until pressure drops 5 PSI.
    - c. Check max PSI with nozzle closed. Minimum pressure: 140 PSI
  5. Use loss of prime method to test over-speed protection cut-out switch.

**C. Refurbishing Procedures**

1. Clean unit as necessary (see E. Cleaning Procedures)
  - Check for oil/fuel leaks prior to washing.
2. Check for loose and/or missing parts or mounting hardware; tighten or replace as needed.
3. Check condition of spark plug, air filter, and fuel filter; clean or replace as needed.
4. Check frame for cracks, repair or replace as necessary.
5. Inspect exhaust system; make sure there are no cracks or leaks.
  - Check for loose and/or missing parts or mounting hardware (especially the intake and exhaust); tighten or replace as needed.
6. Check throttle linkage, tighten bolts as necessary.
7. Check to make sure that all gaskets on the pump fittings/adapters are in place and functioning properly.
8. Ensure all decals (operations and warning) are affixed and legible.
9. Test for performance (see B. Tests.)
10. Remove fuel source and run carburetor completely out of fuel (use choke)



Continued –

ITEM: **PUMP**, portable, Wick-250

NFES #007650

11. Prepare unit for storage. See F. Repackaging.

**D. Retesting Criteria**

1. Retest if date last tested (DLT) is exceeded or starter seal is broken.
2. Ensure C. Refurbishing Procedures is completed.

**E. Cleaning Procedures**

1. Remove dirt, oil and grease, using detergent or degreaser as necessary.
2. Use pressure washer to remove heavy soil.
3. Use pressure washer only if you will start and run the pump the same day.

**F. Repackaging**

1. Use nylon zip-tie to tie off (seal) starter rope to handle bar, to later determine if equipment has been used.
2. Attach certification tag; that indicates; pump output pressure, date last tested (DLT), property #, and name of individual certifying performance.
3. Ensure that all identification (property #, serial #, owner ID) is affixed and legible.
4. Ensure that the pump head is drained of water.

**G. Storage and Shelf Life Checks**

- ✓ Recommendation: Use a fuel stabilizer in fuel during testing to help ensure proper operation of engine at post storage start up.

Ensure that date last tested (DLT) does not exceed 12 months.

**H. References**

[www.mercedestextiles.com](http://www.mercedestextiles.com)

[www.usmotorpower.com](http://www.usmotorpower.com)

---

## Fire Equipment Storage and Refurbishing Standards

---

ITEM: **PUMP**, volume, trash 2", trash 3"

NFES #000683, #001222

### A. Initial Inspection/Disposal Criteria

- ✓ NOTE: Follow the manufacturer's safety precautions as listed in the owner's manual prior to operation of this item.
- ✓ If unit is not economically repairable it should be disposed of using local agency policy.
  1. Visually inspect for evidence of use (dust, oil, starter seal broken), damage or missing parts.
  2. Return to stock if: there is no sign of use or damage and date last tested (DLT) does not exceed 12 months.
  3. Refurbish as necessary if unit has been used, damaged, or shelf life is exceeded.

### B. Tests

- ✓ NOTE: Refer to the owners' manual for operations and specifications information specific to pump model.
- ✓ Check condition of fuel and engine oil; ensure fuel is fresh and oil level is sufficient for running tests (see G. Storage and Shelf Life Checks.)
  1. Test function of rewind starter, ensure proper engagement of engine and recoil functionality.
  2. Check for damage or fraying of pull cord. Repair or replace as necessary.
  3. Engine should: start easily, run smoothly, be free from leaks (oil/fuel), and provide sufficient power to the pump end.
  4. Ensure engine operational controls are functioning properly; stop switch, throttle and choke.
  5. Test for pump performance (see owner's manual for specific performance data).
  6. Ensure pump seal is not leaking, repair or replace as necessary.

### C. Refurbishing Procedures

- ✓ NOTE: If this equipment is taken to a "factory authorized" repair facility for refurbishment; ensure that they receive a copy of this refurbishment standard. The repair facility must; satisfy both, the requirements as set by the manufacturers' specification and to the agreement made with agency.
  1. Clean unit as necessary (see E. Cleaning Procedures.)
  2. Check for oil/fuel leaks prior to washing.
  3. Check for loose and/or missing parts or mounting hardware; tighten or replace as needed.
  4. Check condition of engine oil, spark plug and air filter; clean or replace as necessary.
  5. Inspect exhaust system; make sure there are no cracks or leaks.
  6. Clean spark arrestor of excess carbon build up, replace screen if damaged.
  7. Ensure all decals (operations and warning) are affixed and legible.
  8. Check to make sure that all gaskets on the pump fittings/adapters are in place and functioning properly.
  9. Test for performance (see B. Tests.) Should any function fail a test, refer to the manufacturer's repair manual and troubleshooting guide to correct the problem.
  10. Remove all gasoline from fuel tank and fuel line.
  11. Run engine until carburetor is completely empty of gas (use choke).
  12. Remove all water from pump end.
  13. Prepare unit for storage (see F. Repackaging.)

Continued –

ITEM: **PUMP**, volume, trash 2”, trash 3”

NFES #000683, #001222

**D. Retesting Criteria**

1. Retest if date last tested (DLT) is exceeded or starter seal is broken.
2. Ensure C. Tests is completed.

**E. Cleaning Procedures**

1. Remove dirt, oil and grease, using detergent or degreaser as necessary (use pressure washer to remove heavy soil).
2. Use pressure washer, only if; you will start and run the pump the same day.

**F. Repackaging**

1. Use nylon zip-tie to tie off (seal) starter rope to frame, in order to determine field use.
2. Attach certification tag; that indicates date last tested (DLT), property #, and name of person certifying performance.
3. Ensure that all identification (property #, serial #, owner ID) is affixed and legible.
4. Ensure that the pump head is drained of water.

**G. Storage and Shelf Life Checks**

✓ **Recommendation:** Use a fuel stabilizer in fuel during testing to help ensure proper operation of engine at post storage start up.

Ensure date last tested (DLT) does not exceed 12 months.

**H. Reference**

[www.hondapowerequipment.com](http://www.hondapowerequipment.com)

[www.homelite.com](http://www.homelite.com)

ITEM: **PUMP**, trombone, backpack, single action

NFES #000151

**A. Initial Inspection/Disposal Criteria**

1. Inspect for obvious damage.
2. Inspect for burns and cracks if so dispose of.
3. Inspect for damaged threads, if beyond repair dispose of.

**B. Tests**

Place hose in water and pump handle to validate that the pump works properly.

**C. Refurbishing Procedures**

1. If pump pressure is still not sufficient, remove pump unit and replace O-rings.
2. Inspect quick connection on pump for proper seating.
3. Inspect hose connection to pump for tightness; if loose, use a hose clamp.
4. Inspect supply hose on pump assembly for obstructions and tight connections, bent push rods, and clogged tips.
5. Inspect spring and ball bearing.
6. Lubricate slide with appropriate lubricant, e.g., Chevron NLGI2 or equivalent.

**D. Retesting Criteria-- none**

**E. Cleaning Procedures**

1. Wash and clean all items of foreign matter, such as mud, dirt, and grease.
2. Clean in mild detergent with brush or scouring pad as needed.
3. Rinse thoroughly.

**F. Repackaging**

Local cache option.  
Mark with date of inspection and testing.

**G. Storage and Shelf Life Checks**

Retest if stored for 5 years or longer without use.

ITEM: **RAKE**, collapsible

NFES #000659

**A. Initial Inspection/Disposal Criteria**

1. Inspect for damaged/missing tines, if so dispose of.
2. Inspect for damage to handle sliding-locking mechanism, repair or dispose of.
3. Inspect all welds to see if cracked or broken, repair or dispose of.
4. Inspect grips for tears/loss of grips, repair or dispose of.
5. Inspect nuts and bolts to make sure they are in place (2 each), repair or replace.
6. Inspect pin in locking mechanism, repair or replace.

**B. Tests**

1. Inspect slide mechanism to see if moves freely and does not bind up when expanding tines of rake.
2. Expand tines and inspect all tines to see if secure and stable.

**C. Refurbishing Procedures**

1. Clean with water, let stand and dry.
2. Repair/replace nuts, bolts, and pins as needed.
3. Replace rubber handles.

**D. Retesting Criteria -- none**

**E. Cleaning Procedures**

1. Damp wipe with mild detergent solution to remove dirt, mud, and grease.
2. Let stand and dry.
3. Lubricate slide mechanism with WD 40 or similar solution.

**F. Repacking**

Place 10 each in carton 8" X 20" X 50½" or equivalent to NFES #000037

**G. Storage and Shelf Life Checks -- none**

**H. Reference**

- The manufacturer of this item is:  
Mercedes Textiles Ltd.  
16633 Hymus Blvd.  
Kirkland. QC. Canada H9H 4R9  
Web site <http://www.mercedestextiles.com/english>

Phone: 514-697-0817  
Fax: 514-697-5297

- Various nuts, bolts, and locking pins may be procured at a local hardware store.

## Fire Equipment Storage and Refurbishing Standards

---

ITEM: **RAKE**, fire (council tool) w/sheath

NFES #001807

**A. Initial Inspection/Disposal Criteria**

1. Inspect handles for cracks, splinters, and warping, if so dispose of.
2. Inspect cutting teeth for cracks, excessive wear, replace teeth as necessary.
3. Inspect for loose rivets, tighten or replace loose.
4. Inspect mounting head for cracks, loose handles, dispose of if cracked.

**B. Tests**

1. Apply pressure on handle, inspecting for cracks or splinters overlooked in visual inspection.
2. Hand check each cutter tooth for loose rivets.

**C. Refurbishing Procedures**

1. Replace broken, cracked, or splintered handles.
2. Replace broken or cracked tooth, flat surface inside.
3. Tighten loose rivets.
4. Grind on even bevel, use sickle stone.
5. Retain square point on cutter teeth. **DO NOT ROUND CORNERS.**
6. Paint head with rust inhibitor.
7. Smooth handle with fine sandpaper.

**D. Retesting Criteria -- none**

**E. Cleaning Procedures**

1. Clean head with fine wire brush.
2. Clean handle with damp cloth.

**F. Repackaging**

1. Oil cutting edge.
2. Sheath with NFES #001854 McLeod sheath.
3. Package 10 each in carton NFES #000305 (56" X 20" X 11") (NSN 8115-00-139-0690).

**G. Storage and Shelf Life Checks**

Per local cache requirements to ensure proper serviceability of tools.

---

## Fire Equipment Storage and Refurbishing Standards

---

ITEM: **REDUCERS**

NFES #000009, #000010, #000417, #000418  
#000685, #000733, #002229, #002230, #000402

**A. Initial Inspection/Disposal Criteria**

- Inspect for obvious damage.
  - Cracks—dispose of
  - Bad threads--repair or dispose of
  - Gaskets—stiff, cracked or worn—dispose; if missing--replace
  - Inspect for fire damage--dispose (may cause future failure.)

**B. Tests -- none**

**C. Refurbishing Procedures**

1. Replace gaskets if stiff, damaged, or missing.
2. Inspect male threads.  
If they are damaged try using a triangular file to remove burrs, dings, etc.

**D. Retesting Criteria**

- Re-inspect damaged threads by fitting with appropriate female fitting.
  - If not smooth fit, dispose of item.

**E. Cleaning Procedures**

1. Clean in mild detergent with a brush or scouring pad or high-pressure wash.
2. Rinse thoroughly.
3. Stand upright to drain and dry.

**F. Repackaging**

Local cache option

**G. Storage and Shelf Life Checks -- none**

## Fire Equipment Storage and Refurbishing Standards

---

ITEM: **SHELTER**, fire, complete

NFES #000169

Item obsolete January 2010. Refer to <http://www.nwcg.gov/general/memos/nwcg-013-2009.pdf>

- A. Initial Inspection/Disposal Criteria--none**
- B. Tests -- none**
- C. Refurbishing Procedures--none**
- D. Retesting Criteria -- none**
- E. Cleaning Procedures--none**
- F. Repackaging--none**
- G. Storage and Shelf Life Checks--none**



## Fire Equipment Storage and Refurbishing Standards

---

ITEM: <b>SHELTER</b> , fire, complete, M-2002	NFES #000925
<i>Components:</i>	
SHELTER, fire, M-2002	NFES #000926
CASE, carrying, fire shelter, M-2002	NFES #000927
LINER, fire, shelter carrying case, M-2002	NFES #000928

### A. Initial Inspection/Disposal Criteria

#### ✓ DO NOT OPEN POLYVINYL BAG FOR INSPECTION.

##### Shelter:

1. Inspect polyvinyl bag for cuts, puncture, torn seams, if the bag has any that may affect the integrity of the bag or the shelter, remove shelter from service. See H. Reference.
2. Inspect that the red quick-opening tear strip is unbroken and it is sealed to the bag the entire length, pull rings should be unbroken, if not, remove shelter from service. See H. Reference.
3. Look through bag at shelter for tears along seams.
  - a. If any tears evident, or if sufficient gray discoloration of the interior of the polyvinyl bag to obscure interior inspection, remove shelter from service and use for training or dispose of.
  - b. If there is any doubt about the condition of the shelter or polyvinyl bag, REMOVE FROM SERVICE.
4. Due to the high cost of these shelters, rather than dispose of shelters that show damage to the polyvinyl bag but not to the shelter itself, it is recommended that these shelters be stored until sufficient shelters are available for re-bagging to be economical. See H. Reference.

##### Carrying Case

1. Inspect for cuts, tears, torn seams or flap.
  - o If any found that are un-repairable, remove from service.
2. Ensure that *M-2002 Use Instructions* (English on one side, Spanish on the other) are in the "Use Instructions" pocket on the front.
3. Check that there are two belt clips and that they are in good working condition.

##### Polyvinyl Liner

1. Inspect the polyvinyl liner for cracks or tears.
2. If there is any evidence of damage the liner should be disposed of.

### B. Tests -- none

### C. Refurbishing Procedures

1. If necessary, replace Use Instructions with *M-2002 Use Instructions* (English on one side, Spanish on the other.)
2. If necessary, replace belt clips.
3. If necessary, replace polyvinyl bag at an authorized facility.
4. If necessary replace canvas carry case and/or hard plastic liner.

### D. Retesting Criteria -- none

## Fire Equipment Storage and Refurbishing Standards

---

Continued --

ITEM: <b>SHELTER</b> , fire, complete, M-2002	NFES #000925
<i>Components:</i>	
SHELTER, fire, M-2002	NFES #000926
CASE, carrying, fire shelter, M-2002	NFES #000927
LINER, fire, shelter carrying case, M-2002	NFES #000928

### **E. Cleaning Procedures**

1. Clean Fire Shelter off with damp cloth.
2. Allow any mud and loose dirt on carrying case to dry, and then remove with a stiff brush.
3. Remove oil on carrying case using a solution of warm water and detergent and a brush. 4. Rinse with clear water, let dry.

### **F. Repackaging**

1. Complete Fire Shelters are packed 10 per box.
2. Shelters without carrying case & liner are packed 10 per box.
3. If not part of the Complete Fire Shelter, pack 100 carrying cases in a commercial carton, Style RSC, Type CF, class domestic, grade 275, sized to fit.
4. If not part of the Fire Shelter, Complete, M-2002, pack 100 liners in a commercial carton, Style RSC, Type CF, class domestic, grade 275, sized to fit.

### **G. Storage and Shelf Life Checks -- none**

### **H. Reference**

*Fire Shelter Inspection Guide and Rebag Direction*, 1151 2301P.

Petrilli, Tony. 2011. U.S. Department Of Agriculture, Forest Service, Missoula Technology and Development Center, 6 P. (log on: USERNAME and PASSWORD: t-d)

[HTTP://WWW.FS.FED.US/T-D/PHP/LIBRARY\\_CARD.PHP?P\\_NUM=1151%202301P](http://www.fs.fed.us/t-d/php/library_card.php?p_num=1151%202301P)

---

## Fire Equipment Storage and Refurbishing Standards

---

ITEM: <b>SHELTER</b> , fire, practice, complete, M-2002	NFES #002678
<i>Components:</i>	
SHELTER, fire, practice, M-2002	NFES #002679
POLYVINYL BAG, practice fire shelter, M-2002	NFES #002681
CASE, carrying, fire shelter, practice, M-2002	NFES #002680
LINER, fire shelter, carrying case, M-2002	NFES #000928
SHELTER, fire, practice	NFES #002407

### **A. Initial Inspection/Disposal Criteria**

1. Practice Fire Shelter
  - a. Unfold practice fire shelter and inspect for tears, ripped seams, punctures.  
If not economically repairable, dispose of.
2. Polyvinyl Bag
  - a. Inspect the bag for cracks or tears.  
If there is any evidence of damage, the bag should be disposed of.  
Replace with NFES 2681.
  - b. Inspect that there is a Velcro pull strip and that it is not damaged.
3. Carrying Case
  - a. The M-2002 Practice Fire Shelter Carrying Case is orange in color.
  - b. Inspect for cuts, tears, torn seams or flap.  
If any found that are unrepairable, dispose of.
  - c. Ensure that a M-2002 use instruction sheet and a folding instructions sheet are in the Use Instructions pocket on the front.
  - d. Check that there are two belt clips and that they are in good working condition.
4. Liner
  - a. Inspect the plastic liner for cracks or tears.  
If there is any evidence of damage the liner should be disposed of.

### **B. Tests -- none**

### **C. Refurbishing Procedures**

1. Make repairs as necessary and economical.
2. If necessary, replace Use Instructions with M-2002 Use Instructions, English on one side, Spanish on the other.
3. If necessary, replace Folding Instructions with M-2002 Folding Instructions.
4. If necessary, replace belt clips.
5. If necessary replace polyvinyl bag, NFES# 002681

### **D. Retesting Criteria -- none**

### **E. Cleaning Procedures**

1. Clean Practice Fire Shelter and Polyvinyl Bag with wet cloth.
2. Allow any mud and loose dirt on carrying case to dry, and then remove with a stiff brush.
3. Remove oil from carrying case using a solution of warm water and detergent and a brush.
4. Rinse with clear water, let dry.

---

## Fire Equipment Storage and Refurbishing Standards

---

Continued –

ITEM: <b>SHELTER</b> , fire, practice, complete, M-2002	NFES #002678
<i>Components:</i>	
SHELTER, fire, practice, M-2002	NFES #002679
POLYVINYL BAG, practice fire shelter, M-2002	NFES #002681
CASE, carrying, fire shelter, practice, M-2002	NFES #002680
LINER, fire shelter, carrying case, M-2002	NFES #000928
SHELTER, fire, practice	NFES #002407

**F. Repackaging**

1. Complete Practice Fire Shelters are packaged 10 per box.
2. Pack 10 Practice Fire Shelters (without polyvinyl bag, carrying case and liner) in a close fitting commercial carton, Style RSC, Type, I class domestic, grade 275, size 16" X 10" X 12".
3. If not part of the Practice Fire Shelter, Complete, M-2002, pack 100 carrying cases in a commercial carton, Style RSC, Type CF, class domestic, grade 275, sized to fit.
4. If not part of the Practice Fire Shelter, Complete, M-2002, pack 100 polyvinyl bags in a commercial carton, Style RSC, Type CF, class domestic, grade 275, sized to fit.
5. If not part of the Practice Fire Shelter, Complete, M-2002, pack 100 liners in a commercial carton, Style RSC, Type CF, class domestic, grade 275, sized to fit.

**G. Storage and Shelf Life Checks -- none**

## Fire Equipment Storage and Refurbishing Standards

---

ITEM: **SHIRT**, fire

All Sizes

### A. Initial Inspection/Disposal Criteria

1. Inspect for holes, cuts, tears, or torn seams--if not economical to repair, then dispose of.
2. Inspect buttonholes for frayed or broken stitching and mend if possible--if unable to mend then dispose of.
3. Inspect for missing or tack buttons--if unable to mend then dispose of.
4. Inspect all hooks and pile fasteners to ensure they provide adequate closure. Repair or replace if economically feasible, or dispose of.
5. Inspect for pitch or oil--if can't be cleaned dispose of.
6. Inspect for any markings on shirts--if marked dispose of.
7. Exposure to poison ivy/oak/sumac is NOT disposal criteria. However, extra care should be taken when handling contaminated clothing.
8. Shirts laundered to unknown specification shall be re-laundered following the guidelines in E. Cleaning Procedures.

### B. Tests

Open and close hook and pile fasteners. They should provide an adequate and secure closure.

### C. Refurbishing Procedures

✓ Use Nomex® (Aramid) thread and materials for all repairs.

1. Repair any hole, cut, tear, or torn seam by darning or patching, duplicating the original construction. See note in A. Initial Inspection/Disposal Criteria.
2. Over stitch any frayed buttonhole using a buttonhole or zigzag stitch that has 50 to 60 stitches per buttonhole.
3. Replace damaged hook and pile fastener tape with tape of the same length, width, and quality as the original. See note in A. Initial Inspection/Disposal Criteria.

### D. Retesting Criteria

Test all replacement hook and pile fasteners after sewing in place, as specified in B. Tests.

### E. Cleaning Procedures

See [www.personalprotection.dupont.com](http://www.personalprotection.dupont.com)

See Appendix A--Cleaning Instructions

See Appendix A--Nomex Clothing Exposed to Poison Oak/Ivy/Sumac

DO NOT USE BLEACH TO CLEAN FABRIC.

### F. Repackaging

Package 50 each of same size in carton NFES #002007 (24" X 16" X 16") (NSN 8115-00-292-0123).

### G. Storage and Shelf Life Checks -- none

### H. Recycling

Leigh Fibers Inc., ATTN: Nelson Smith

1101 Syphirt Rd., Wellford, SC 29385

Make contact with vendor to establish requirements and feasibility.

Ph: 864-439-4111

## Fire Equipment Storage and Refurbishing Standards

---

ITEM: SHOVEL, with plastic sheath, size # 1

NFES #000171

### A. Initial Inspection/Disposal Criteria

1. Obvious damage to cutting head, step plate, and handle. (Dispose)
2. Loose head, severely rounded, distorted or bent blade.(Dispose)
3. Blade less than 3¾” from center to edge on both sides.(Dispose)
4. Blade has been modified by improper grinding or filing, such as modification of step plate.(Dispose)
5. Short or nonstandard handle, handle not straight, handle cracked or chipped.(Dispose)

### B. Tests/Inspections

1. Head.
  - a. Blade distortion or bent.
  - b. Blade to be at least 7½” wide. USE TEMPLATE
  - c. Shank not bent or handle base tilted.
  - d. Blade tip that has been severely rounded.
2. Handle.
  - a. Handle must be straight.
  - b. Inspect for cracks, chips, or open grain.
  - c. Inspect for tape residue, or other residue (tar, sap, etc.).

### C. Refurbishing Procedures

✓ **Caution: Tool should NEVER be ground to the degree that the metal temperature raises high enough to remove temper, i.e., blue or burned edges.**

1. Head and handle.
  - a. Wash and wipe dry.
  - b. Sand handle if it is rough, chipped, dinged, or has any type of residue.
  - c. Sharpen cutting edge using tool sharpening gauge NFES #000510.

### D. Retesting Criteria -- none

### E. Cleaning Procedures

See C. Refurbishing Procedures.

### F. Repackaging

1. Install plastic sheath NFES #001853.
2. Package 10 each in carton NFES #000337 (55” X 12½” X 11¾”) (NSN 8115-00-139-0689).

### G. Storage and Shelf Life Checks

Inspect once per year for rust and loose handles

### H. References

[New and Improved Flap Cup Grinder Disc](#)

ITEM: **SHROUD**, face & neck, Nomex® w/front closure

NFES #001274

**A. Initial Inspection/Disposal Criteria**

1. Inspect for holes, cuts, tears, or torn seams. If not economical to repair, then dispose of.
2. Inspect all hooks and pile fastener to ensure they provide adequate closure, repair or replace if possible, or dispose of.

**B. Tests**

Open and close the hook and pile fasteners to ensure that they provide an adequate and secure closure.

**C. Refurbishing Procedures**

1. Repair holes, cuts, tears, burns, and torn seams by darning, patching, or by duplicating the original construction (see A. Initial Inspection/Disposal Criteria.)
2. Replace damaged hook and pile fastener tape with tape of the same length, width, and quality as the original (see A. Initial Inspection/Disposal Criteria.)

**D. Retesting Criteria**

Test all replacement hook and pile fasteners after sewing in place, as specified in B. Tests.

**E. Cleaning Procedures**

See <http://www.personalprotection.dupont.com>

DO NOT USE BLEACH TO CLEAN FABRIC.

See Appendix A–Cleaning Instructions.

**F. Repackaging**

Lay with inside up, fold both sides towards middle, fastening hook and loop fasteners.

Pack 20 shrouds in carton to be determined.

**G. Storage and Shelf Life Checks -- none**

ITEM: **SPOUT**, gas, flexible, 16” steel

NFES #000210

**A. Initial Inspection/Disposal Criteria**

1. Visual inspection for obvious damage.
2. Bent or crushed sections in flexible portion, dispose of unit.
3. Replace, cracked, or stiff gasket on bottom of spout.
4. Replace screen on pouring end.
5. Visual inspection of spout for obstructions.
6. Inspect locking flange to ensure it is in working condition. If not, dispose of unit.

**B. Tests -- none**

**C. Refurbishing Procedures**

1. If possible, replace tail gasket if missing, cracked, or stiff.
2. If possible, replace screen. If unable to replace screen, dispose of unit.  
Try to salvage screens from disposed items.
3. Remove any obstructions that may be in spout.
4. Clean screen and threads on screen cap.
5. Can be washed using a pressure washer.

**D. Retesting Criteria -- none**

**E. Cleaning Procedures**

1. Clean completely with solvent or high-pressure wash. **Use in a well-ventilated area.**
2. Stand on end or lay unit down to drain and dry.
3. Make sure spout is completely dry before repacking.

**F. Repackaging**

Local cache option for carton.

**G. Storage and Shelf Life Checks -- none**



ITEM: **SWATTER**, fire

NFES #001868

**A. Initial Inspection/Disposal Criteria**

1. Inspect handle, flapper, and metal that connect the two parts.
2. Dispose of if handle is cracked or broken, flapper has large chunks missing, or is badly weathered.

**B. Tests**

1. Push down on handle to check for strength, cracks.
2. Look down length of handle to check for warping.
3. Ensure that connection between handle and flapper is in good condition.

**C. Refurbishing Procedures**

1. Visually inspect flapper condition. No repair to flapper--if damaged, dispose of.
2. Check handle for roughness. Sand down handle until smooth if necessary.

**D. Retesting Criteria -- none**

**E. Cleaning Procedures**

Wire brush and wash any mud and residue off handle and flapper.

**F. Repackaging**

Cache option for repacking swatters in bundles of 5 or 10 and plastic wrap the handles into group. Store in this condition (at this time tool is not boxed).

**G. Storage and Shelf Life Checks**

Per local cache requirements to ensure proper serviceability of tools.

ITEM: SWIVEL, cargo, 3,000 lb capacity  
SWIVEL, cargo, 6,000 lb capacity

NFES #000526  
#000286



**A. Initial Inspection/Disposal Criteria**

1. Inspect swivel for rotation--see B.1
2. Inspect hook for damage, wear, and deformation--see B.2.a, b and c.
3. Inspect hook safety gate latch operation--see B.2.b, if gate is a spring gate replace.
4. Inspect link for damage, wear and deformation--see B.4.a, b and c.
5. Inspect hook and link attachment points--see B.4 b and c

**B. Test Inspections**

1. Inspect swivel.  
Swivel shall rotate freely by hand (no binding) with no load. If swivel does not rotate freely, remove from service. If binding is suspected, perform the following free rotation test. Using a string, hang a 2 lb. weight to the hook. Close the hook and rotate the swivel slowly in one direction and then the other. The speed of rotation shall not be greater than 1 revolution in 5 seconds. If the binding of the swivel results in the string being carried around the rotation, remove the swivel from service. See C. Refurbishing Procedures.

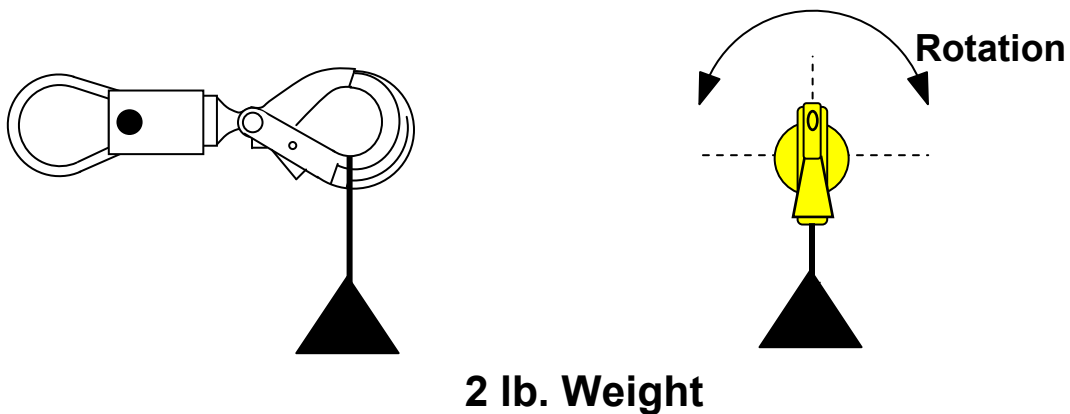

Figure 1. Free Rotation Test

Continued --

ITEM: **SWIVEL**, cargo, 3,000 lb capacity  
**SWIVEL**, cargo, 6,000 lb capacity

NFES #000526  
#000286

2. Excessive lateral movement of the swivel may indicate bearing wear. Excessive lateral movement is defined as 5 degrees (angular measurement) of total movement. Remove from service.

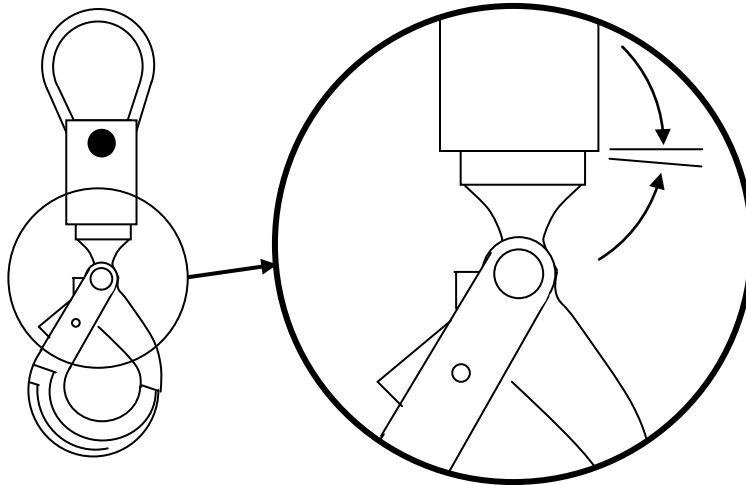

**Lateral Movement**

Figure 2. Excessive Lateral Movement

- a. Inspect swivel rotating body or hook for any cracks or gouges. If cracks or gouges are found, remove from service and return to manufacturer.
- b. Inspect gate for type. If the gate is a spring gate (the hook opens by pushing the gate into the hook) it is an old style hook and needs replacement. Remove the swivel from service and refer to NFES Cache Memorandum No. 04-03, Cargo Swivel Retrofit Project dated 8/10/04. [http://www.nifc.gov/nicc/logistics/cachememo/cm\\_NFES-cargo\\_08-10-04.pdf](http://www.nifc.gov/nicc/logistics/cachememo/cm_NFES-cargo_08-10-04.pdf)
- c. Inspect the swivel for the dimensions shown in figure 3 and table 1. If dimensions exceed those in table 1, remove the swivel from service. See C. Refurbishing Procedures.

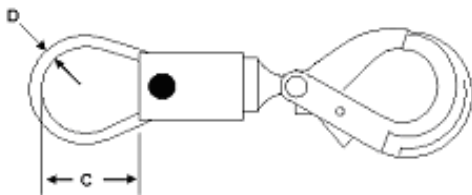

Figure 3. Swivel Dimensions

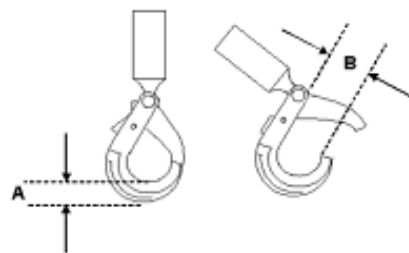

Figure 4. Shank Hook

Continued --

ITEM: **SWIVEL**, cargo, 3,000 lb capacity  
**SWIVEL**, cargo, 6,000 lb capacity

NFES #000526  
 #000286

Table 1. Swivel Dimensions

Style	C	D
3000 pounds	3 to 5 inch max	5/8-inch nominal
6000 pounds	3 to 5 inch max	5/8-inch nominal

Table 2. Shank Hook Dimensions

Style	A (max)	B (max)
3000 pounds	1.0 inch	1.33 inch
6000 pounds	1.3 inch	1.7 inch

3. Inspect Hook
  - a. Inspect the hook for the dimensions shown in figure 4 and table 2. If dimensions exceed those in table 2, remove the swivel from service. See C. Refurbishing Procedures.
  - b. Check the hook for damage such as cracks, nicks, wear, gouges, and deformation. Check operation and ensure that hook is not bent or distorted. If any damage is found, then remove from service. See H. Salvage.

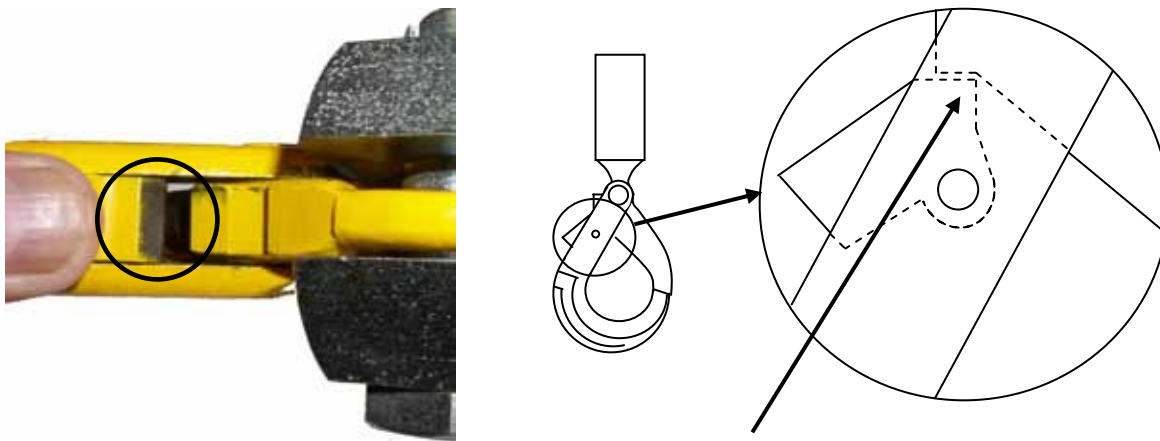

**Check for rounding of Lock Shoulder Here**

Figure 5. Examine Gate Lock Latch for rounding.

- c. Check the hook's locking gate operation.
      - Ensure safety latch open and close completely.
      - Examine latch for damage or distortion.
      - Examine lock latch for rounded edge, see Figure 5.
      - Ensure spring loaded latch hold the latch in the closed position.
      - Ensure lock latch pin is secure and flush with the latch, see figure 5. If latch is damaged, does not operate as required, missing hardware, or does not meet dimensional requirements remove from service. See H. Salvage.

Continued –

ITEM: **SWIVEL**, cargo, 3,000 lb capacity  
**SWIVEL**, cargo, 6,000 lb capacity

NFES #000526  
#000286

4. Link

a. Inspect the link.

- Check for damage such as cracks, nicks, wear, and gouges.
- Check link for deformations. The curved ends of the link (either oblong or pear) should be generally circular in shape. If overstressing has occurred, the end portions of the link will appear “pinch.” Figure 6 shows the pinched affect of overstressed parts.

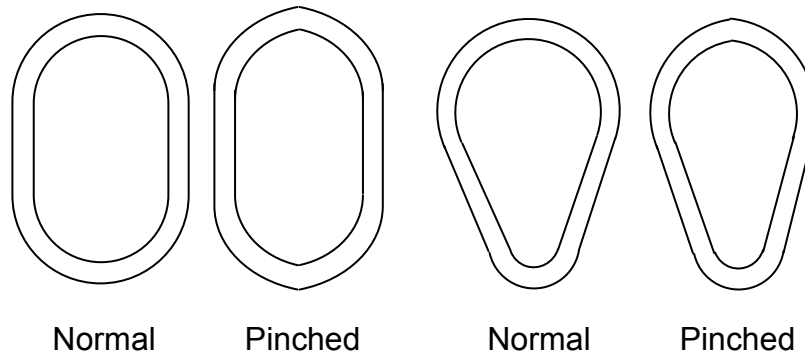

Figure 6. Normal and “pinched” link shapes. **If link is damaged then remove from service.** See C. Refurbishing Procedures.

b. Inspect the link attachment fastener.

- If the link is to the swivel with a threaded fastener with nut:
    - Ensure that no more than 2 threads are exposed.
    - Ensure that fastener has not slipped by inspecting the paint indication. See Figure 7.
- If slippage is indicated, see C. Refurbishing Procedures.

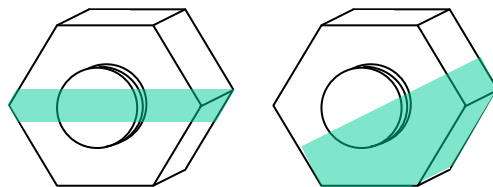

Figure 7. Slippage paint indication.

c. Inspect the fastener and nut for damage (cracks and gouges).

- If the link is attached with a pin secured with roll pins, ensure that the roll pins are not bent or cracked.
- If damage is observed, see C. Refurbishing Procedures.

Continued –

ITEM: **SWIVEL**, cargo, 3,000 lb capacity  
**SWIVEL**, cargo, 6,000 lb capacity

NFES #000526  
 #000286

**C. Refurbishing Procedures**

1. Swivel rotation binding and lateral movement repairs. These repairs shall be performed by the manufacturer or certified/qualified rigging facility. The typical repair is the replacement of the bearing. If the bearing is replaced, the replacement bearing shall be capable of a bearing load 3.75 times the swivel’s rated capacity.
  2. Hook and link problems. The hooks and links of a swivel shall not be altered, rework, or reshaped. They may be replaced. Replacement components shall have a strength capacity of 3.75 times the load carrying capacity of the swivel. Return the swivel to the manufacturer or certified rigging facility for all replacement parts or repairs.
  3. Repaint the fastener slip indicator when necessary. Paint as shown in figure 7.
- ✓ **NOTE:** All above repaired swivels (including replaced components) shall be tested per D. Retesting Criteria.
4. Link retaining fastener. Threaded link retaining fasteners that use a bolt and self-locking nut, may be retightened in accordance with the table 2: Link Fastener Torque Values. Then paint as shown in figure 7. Other fastener systems shall be sent to the manufacturer to be repair.

Table 2. Link Fastener Torque Values

Fastener Size	Torque (Ft-lbs.)
5/16	12
3/8	20
7/16	25
1/2	30

- ✓ **NOTE:** Never repair, alter, rework, or reshape a hook or swivel. Return to the manufacturer or qualified rigging company for repair.

**D. Retesting Criteria**

1. Repairs must be performed by the manufacturer or certified/qualified rigging facility.
2. Each and every repaired swivel shall be strength tested to 2.0 times its rated capacity. The swivel shall be placed into a tensile style loading device that has a current calibration. The swivel shall be tensile loaded to 2.0 times the rated capacity of the swivel. The swivel shall not show any signs of damage (see B. Tests) due to loading.
3. Each and every swivel whose bearing is repaired swivel shall pass the following tests:
  - a. Free rotation. Open the hook. Rotate the swivel until the ‘jaw’ of the hook is down. Rotate the swivel slowly in one direction and then the other. The speed of rotation shall not be greater than 1 revolution in 5 seconds. The jaw should be held (due to gravity) to an orientation less than 135 degrees from vertical. If the binding of the swivel results in the jaw of the hook rotating over the top the repair is unacceptable.

Continued –

ITEM: **SWIVEL**, cargo, 3,000 lb capacity  
**SWIVEL**, cargo, 6,000 lb capacity

NFES #000526  
#000286

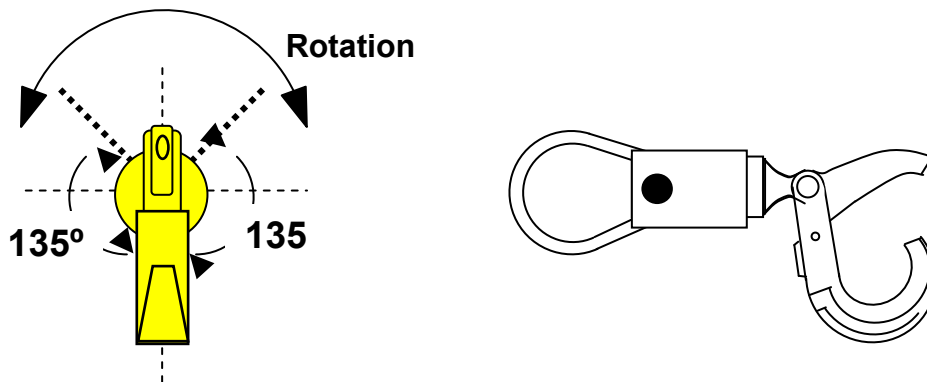

Figure 8. Free Rotation, Unloaded.

- b. The lateral movement test of B.2 described above, except that maximum lateral movement shall be less than 2 degrees (see figure 2.)
- 4. All replacement hardware (links, bearings, hooks) shall have a minimum working load limit equal to the safe working load of the corresponding swivel; and have a minimum ultimate strength equal to 11,250 pounds for 3000-lb capacity swivels and 22,500 pounds for 6,000-lb capacity swivels. Links and hooks shall meet the requirements of USDA Forest Service Specification for Swivel, 5100-506 for 6,000-lb swivels and 5100-501 for 3,000-lb swivels.
- 5. Each and every swivel whose link is replaced shall meet the dimensional requirements of B.2 table 1.
- 6. Each and every swivel whose hook is replaced shall meet the dimensional requirements of B.2 table 2.
- 7. For replaced shank style hooks, the threading of the hook shall follow the hook manufacturer's recommendations.

**E. Cleaning Procedures**

Wipe clean. Paint as needed.

**F. Repackaging**

Pack 6 each NFES #000526 in carton (cache option) and label accordingly  
Pack 5 each NFES #000286 in carton (cache option) and label accordingly.

**G. Storage and Shelf Life Checks --none**

**H. Salvage**

Salvage all useable hardware prior to disposing of swivel.  
Salvage material can be sent to San Dimas Technology and Development Center.

**I. Reference**

NFES Cache Memo No. 04-03  
[http://www.nifc.gov/nicc/logistics/cachememo/cm\\_NFES-cargo\\_08-10-04.pdf](http://www.nifc.gov/nicc/logistics/cachememo/cm_NFES-cargo_08-10-04.pdf)

## Fire Equipment Storage and Refurbishing Standards

---

ITEM: **TABLE**, mess, 4 person  
**TABLE**, folding

NFES #001390  
#002698

**A. Initial Inspection/Disposal Criteria**

1. Inspect for table surface damage.
2. Inspect for broken or bent legs.
3. Inspect for rough cutting surface edges.
4. Inspect for missing items and supports.
5. If folding table, and legs or top cannot be repaired, dispose of the unit.

**B. Tests -- none**

**C. Refurbishing Procedures**

1. Metal/plastic suitcase mess table: repair damage area by welding, pop riveting or by gluing.
2. Folding table: try to repair legs and top and if possible straighten any dents and miscellaneous damage to metal folding tables.

**D. Retesting Criteria--none**

**E. Cleaning Procedures**

1. High pressure wash or wipe tables with household cleaner suitable for the table surface.
2. Remove any foreign matter on tables, such as gum.
3. Let table stand to dry.

**F. Repackaging**

1. Suitcase mess table: band case and place in proper location.
2. Folding tables: collapse and place in proper location.

**G. Storage and Shelf Life Checks--none**



---

## Fire Equipment Storage and Refurbishing Standards

---

ITEM: TANK, collapsible, 1,000 GL	NFES #000588
TANK, collapsible, 1,200 GL	#000090
TANK, collapsible, 1,500 GL	#000589
TANK, collapsible, 1,800 GL	#000668
TANK, collapsible, 3,000 GL	#000568
TANK, collapsible, 4,800 GL	#006030
TANK, collapsible, 6,000 GL	#006031

**A. Initial Inspection/Disposal Criteria**

1. Segregate by NFES #.
2. Inspect for obvious punctures, cuts, burns, damaged hose couplings, drain plugs, etc. Tanks with holes larger than 3” should be disposed of.

**B. Tests**

1. Determine that all plugs are present and in good serviceable condition.
2. Secure tank to forklift with a chain of proper size to bear the weight of the tank. Mark all punctures, cuts, etc., while forklift or hoist suspends tank. This allows light to be seen through any obvious problem areas. Use of spotlight can be helpful in finding holes.

**C. Refurbishing Procedures**

1. Repair or replace any damaged plugs or couplings.
2. Clean entire tank with soapy water inside and out.
3. Rinse well with clear water from high-pressure washer.
4. Allow to air dry on both sides.
5. Patch or repair any damaged areas previously noticed. All patches should be welded with patch material that is recommended by the manufacturer.

**D. Retesting Criteria**

1. Suspend tank again so that any holes can be spotted while looking towards light.
2. Refer to C. Refurbishing Procedures. If holes are found, patch and re-inspect.

**E. Cleaning Procedures**

See C. Refurbishing Procedures.

**F. Repackaging**

1. Fold or roll tank as tightly as possible, secure with plastic banding or rope to keep from unrolling.
2. Local cache option for repackaging and labeling.
3. Suggest using NFES #000500 for packing NFES #000589, #000668, #000568.

**G. Storage and Shelf Life Checks--none**

ITEM: **TANK**, dip, 15,000 GL, Heliwell

NFES# 000669

**A. Initial Inspection/Disposal Criteria**

1. Observe condition prior to take down or after setting unit up following manufacturer's assembly procedures.
2. Look at rim covers and inspect attached webbing.
3. Remove rim covers and inspect top of tank for abrasions or tears.
4. Look in tank for slices or holes and mark with felt pen if repairs needed.
5. Inspect panels to ensure they are not bent or misshapen and attached clips are functional.
6. Inspect turn buckles and cables for frays and buffs.

**B. Tests**

Verify panels close together by inspecting placement.

**C. Refurbish Procedures**

1. Weld all cracked or broken welds on aluminum panels.
2. Patch all holes.
3. Rivet rim covers if missing.
4. Straighten panels and replace clips if needed.
5. File off buffs on turn buckles.
6. If major repairs are needed to liner, refer to SEI Industries website for contact information.  
<http://www.sei-ind.com>

**D. Retesting Criteria--none**

**E. Cleaning Procedures**

Clean tank liner and panels using warm soapy water. Steam cleaning, plus brushing efficiently expedites this process.

**F. Repackaging**

1. Fold tank in a shape that fits underneath one panel. See Heliwell operator's manual on SEI website
2. Place folded tank on provided pallet and stack panels atop tank.
3. Box other components, place on pallet, and strap down securely.

**G. Storage and Shelf Life Checks--none**

## Fire Equipment Storage and Refurbishing Standards

---

ITEM: **TANK**, folding, 1,000 GL w/frame  
**TANK**, folding, 1,500 GL w/frame

NFES #000661  
#000664

### **A. Initial Inspection/Disposal Criteria**

1. Frame broken or bent beyond repair--dispose of frame.
2. Liner seam has separation--dispose of liner.
3. Liner has tears larger than 3"--dispose of liner.
4. Liners that have numerous smaller holes should be left to the discretion and good judgment of management.
5. Two or more grommets are missing in succession and new grommets cannot be used due to damage of area--dispose of liner.

### **B. Tests**

Verify hinges operate smoothly.

### **C. Refurbishing Procedures**

1. Straighten frame.
2. Inspect welds for cracks and separation. Repair as needed.
3. Remove rust, paint as needed.
4. Lubricate hinges with appropriate lubricant.
5. Inspect liner seam to verify no separations exist.
6. Inspect for holes and tears, patch by welding material recommended by the manufacturer.
7. Inspect liner to ensure that it is properly attached to frame through each grommet. The use of cable ties or 1/4" nylon rope is recommended. Ensure that ties and ropes are secure. No damage or fraying. Replace or tighten as necessary.
  - When using cable ties, use one per grommet and utilize large cable ties at corner and midpoints. Use smaller ties in all other grommets.
  - When using rope, secure one end to the frame. Then using a lacing motion, go through the grommet, then over the frame and back through the next grommet. Continue this motion until entire liner is attached to frame. Secure end.
8. Fold the tank ensuring that liner is not pinched during process. Only a minimum, if any, amount of liner is to extend outside the metal frame.

### **D. Retesting Criteria--none**

### **E. Cleaning Procedures**

Use warm soapy water and scrub brushes to clean the frame and liner. A steam cleaner can be used in conjunction with brushes.

### **F. Repackaging**

Fold and stencil with NFES number and:

Band 1,000-gallon tank near both ends.

Band 1,500-gallon tank in middle and at both ends.

### **G. Storage and Shelf Life Checks--none**

ITEM: **TANK**, gasoline, 5 GL (18.9L), pump adapted

NFES #000218

**A. Initial Inspection/Disposal Criteria**

1. Check for fuel and dispose of properly.
- ✓ **NOTE:** Dispose of contaminated fuel according to hazardous material regulations in your area.
2. Check for leaks or separation along seams.
3. Check all threads on connector for serviceability.
4. Inspect gasket on cap. Replace if missing, cracked, or stiff.
5. Inspect for rust, if found, dispose of tank.
6. Inspect and tighten quick release fuel valve.

**B. Tests**

Visual inspection only.

**C. Refurbishing Procedures**

1. Drain all existing fuel and purge.
2. Use an air hose to dry the interior of the container and verify that no grit and or dirt material has dried within female opening of quick disconnect coupling.
3. Turn upside down with lids off or open to dry.
4. Inspect vent hole to ensure it is clean and serviceable.
5. Wipe down outside of container and repaint if necessary.

**D. Retesting Criteria--none**

**E. Cleaning Procedures**

See C. Refurbishing Procedures.

**F. Repackaging**

Local cache option for repackaging.

**G. Storage and Shelf Life Checks--none**

ITEM: **TANK**, propane, fuel, LPG, 20 lb tank (5 GL)

NFES #000491

**A. Initial Inspection/Disposal Criteria**

1. Inspect for rust, dents, punctures, broken valves, and valve handle. Look for weak or broken handle.
2. Confirm test date on propane tank (must be recertified, [hydrostatic testing] 12 years from manufacturer date and every 5 years after the first recertification).
3. Verify handle type to ensure that tank meets current specifications for “OPD” valve.

**B. Tests**

1. Apply soapy water to valve area.
2. Watch for bubbles indicating leaks.
3. Tag immediately for repair or remove from service.

**C. Refurbishing Procedures**

1. Repair or replace defective valves and broken handles. All repairs will be done by an authorized facility.
2. Power wash tank, let dry.
3. Ensure warning labels are visible and replace if necessary.
4. Install plastic cap or plug in valve opening if missing.
5. All repairs will be done by an authorized facility. Ensure valve is in “OFF” position.

**D. Retesting Criteria**

Inspect valve to ensure it is in “OFF” position before issuing.

**E. Cleaning Procedures**

Completed in C. Refurbishing Procedures.

**F. Repackaging**

1. Place on pallets and shrink wrap or tie with cord to ensure tanks do not fall or tip over.
2. Store in secured (no smoking) area; tanks will vent fumes when they get hot.

**G. Storage and Shelf Life Checks**

1. Store in secured (no smoking) area; tanks will vent fumes when they get hot.
2. Attempt to store out of sun.
3. Refer to Forest Service Health & Safety Handbook, OSHA, NFPA, and local direction.

**H. Reference**

1. For more information on propane tank maintenance you can search the internet under “propane tank safety” or OPD valve laws and regulation.

## Fire Equipment Storage and Refurbishing Standards

---

ITEM: **TANK**, Snaptank, 1500 GL and 1000 GL

NFES #007700, 007614

**A. Initial Inspection/Disposal Criteria**

1. Check parts: Should have 8 vertical legs, 16 snap support bars, 1 liner, 1 carrying bag and one 3" plug.
2. Leg or support bars broken or bent beyond repair, dispose of and replace broken parts.
3. Liner seam has separation, dispose of.
4. Liner or carrying bag has tears larger than 3 inches, dispose of.
5. More than 12 patches on liner, dispose of.
6. If loop at top of tank is torn out, dispose of.
7. Check for burrs on all metal parts. Remove burrs with file.

**B. Tests**

Hold liner up to light to see if holes are present and check threads on plug and flange assembly.

**C. Refurbishing Procedures**

1. Repair or replace any part of the frame as needed.
2. Repair liner or bag as needed.
3. Ensure all locking buttons snap into place, lubricate if sticky.
4. File all burrs smooth.
5. Replace plug if necessary. Always place plug on the inside of the tank.
6. See I. References below for major repairs and replacement parts.

**D. Retesting Criteria--none**

**E. Cleaning Procedures**

1. Dismantle and wipe all metal parts with a damp cloth.
2. Clean liner and bag with mild soap and water solution, use a brush if necessary or pressure wash

**F. Repackaging**

Per local cache standard

**G. Storage and Shelf Life Checks--none**

**H. Recycle as local cache options are available.**

**I. References**

[Western Shelter](#)

## Fire Equipment Storage and Refurbishing Standards

---

ITEM: **TEE**, hoseline

NFES #000230, #000731, #001809, #002240

**A. Initial Inspection/Disposal Criteria**

1. Inspect for burrs. Repair.
2. Inspect gasket. Replace if missing, cracked or worn.
3. Ensure that 1” valve is seated properly (NFES #000230). Repair if necessary.
4. Check for fire damage (could cause future failure)

**B. Tests--none**

**C. Refurbishing Procedures**

Replace gasket if missing, cracked, or stiff.

**D. Retesting Criteria--none**

**E. Cleaning Procedures**

1. Clean in mild detergent with a brush or scouring pad or high pressure wash
2. Rinse thoroughly.
3. Stand upright to dry.

**F. Repackaging**

Pack 10 or 60 to container.

**G. Storage and Shelf Life Checks--none**

**H. Recycle as local cache options are available.**

**I. Reference**

NFES Cache Memo No. 10-01

[http://www.nifc.gov/nicc/logistics/cachememo/CM2010-1\\_Hose\\_Line.pdf](http://www.nifc.gov/nicc/logistics/cachememo/CM2010-1_Hose_Line.pdf)

ITEM: **TENT**, 2 person

NFES #000077

**A. Initial Inspection/Disposal Criteria**

✓ Inspect tents immediately upon receipt at cache for moisture. Wet tents will mold quickly. Some mold smells are impossible to remove.

1. Tent body and fly. If a--c exists, dispose of.
  - a. Inspect for any tears, holes, burns, or unraveled seams that are not economically repairable.
  - b. Any zipper that does not provide adequate closure.
  - c. Any missing stretch cords or plastic hooks missing on rain fly.
2. Poles or stakes.
  - a. Cracked or broken poles.
  - b. Cracked or broken hinge joints.
  - c. Bent, broken, or mushroomed tops of stakes.

**B. Tests**

1. Set up the tent with the fly; inspect hinge joints for smooth operation.
2. Open and close all zippers ensuring adequate closure.
3. Inspect stretch cords and plastic clips for cracks and frays.

**C. Refurbishing Procedures**

1. Repair holes, tears, and seams.
2. Replace damaged zippers.
3. Replace nonfunctioning hardware.
4. Remove dirt from stakes with wire brush, straighten and file off burrs.
5. Replace damaged poles.

**D. Retesting Criteria--none**

**E. Cleaning Procedures**

1. Set tent up and sweep, vacuum or shake out dirt and debris.
2. For dirt and light stains, use warm soapy water. Wipe or brush out stain, rinse with clean water, and air dry.
3. See Appendix A--Cleaning Instructions.

**F. Repackaging**

1. Place clean tent into tent bag and secure.
2. STANDARD PACK is 1 per carton recommend carton 30" X 6" X 6"
3. STANDARD PACK is 6 per carton recommend carton 31" X 20" X 13"

**G. Storage and Shelf Life Checks**

Inspect periodically for dampness

**H. References**

[Catoma Outdoor](#)



## Fire Equipment Storage and Refurbishing Standards

---

ITEM: **TENT**, wall, 14' x 16', without poles

NFES# 000084

**A. Initial Inspection/Disposal Criteria**

1. Inspect for nonstandard item, if so dispose of.
2. Inspect for rips and tears, if uneconomical to repair, dispose of.
3. Inspect for mildew, if present dispose of.

**B. Tests--none**

**C. Refurbishing Procedures**

1. Completely unfold tent on clean, dry floor or work area so that any defects (tears, burns, mildew, etc.) will be visible.
2. Sweep off entire tent with stiff-bristle broom.
3. Repair any rips, tears, or other defects at this time if possible. If repairs cannot be made easily and cost effectively, continue to clean tent and tag it for repair.
4. Replace missing or damaged guy ropes (1/4" X 8' manila rope) and ridge lines (1/4" X 12' manila rope) and replace missing or damaged grommets with proper size grommets. Complete tent takes 14 each – 8ft ropes and 2 each – 12ft ropes.
5. Let dry, lace corners, and close and tie door.
6. Fold tent with guy ropes in the center of folding. Fold so that tent does not have to be turned over when set up (outside of tent is facing up when folding).  
14 ea stakes--NFES# 000825 and 22 ea pins--NFES# 000538 to be added.

**D. Retesting Criteria--none**

**E. Cleaning Procedures**

Wash tent with warm water and a mild detergent. If necessary clean stubborn stains with hot water pressure washer using a stiff bristle brush for scrubbing.

**F. Repackaging**

Place 1 each tent in carton NFES #000645 and label accordingly.

**G. Storage and Shelf Life Checks--none**

---

## Fire Equipment Storage and Refurbishing Standards

---

ITEM: <b>TIP</b> , applicator, 3 GPM	NFES #000735
<b>TIP</b> , applicator, 15 GPM	NFES #000736
<b>TIP</b> , nozzle, straight stream and fog	NFES #000635, #000636, #000637 #000638, #000094, #000737

**A. Initial Inspection/Disposal Criteria**

1. Inspect for burns, cracks, or bad threads, if so dispose of.
2. Inspect for gasket (correct or not correct). Replace if needed.
3. Look through tip; if clogged, clean out. Take out disk to clean out on spray tips.

**B. Tests**

1. Attach to hose.
2. Turn on water and ensure that adequate flow and pattern are attained.

**C. Refurbishing Procedures--none**

**D. Retesting Criteria--none**

**E. Cleaning Procedures**

1. Wash and clean all items of foreign matter (i.e., mud, dirt, and grease).
2. High-pressure wash or clean in dishwashing detergent with a brush or scouring pad as needed.
3. Do not soak for extended periods of time or the detergent will corrode the aluminum.
4. Rinse thoroughly.
5. Stand upright to drain water and dry.

**F. Repackaging**

Place 10 each in carton (cache option) or 60 each in carton (cache option) and label accordingly.

**G. Storage and Shelf Life Checks--none**

ITEM: **TOOL**, combination shovel and grub hoe

NFES #001180

**A. Initial Inspection/Disposal Criteria**

1. Inspect for structural damage to pick, hoe blade or both that cannot be repaired by replacing components, if so dispose of.
2. Pick replacement: (see figure 1)
  - If bent or twisted.
  - If shorter than 4½” long in extended position.
  - If cracks exist around hinge leg bolt hole or if hinge leg bolt hole is enlarged.
3. Hoe blade replacement: (see figure 1)
  - If there are cracks or looseness in the area of the hinge leg rivets.
  - If hinge leg bolt hole is enlarged or cracked.
  - If shorter than 6” (measure from turn step to blade tip.)
4. Handle replacement:
  - Cracked, bent, twisted, or has open grain.
  - Has been shortened (except for detachable handle smokejumper version, which has a 4” shorter handle).
  - Has a nonstandard handle.

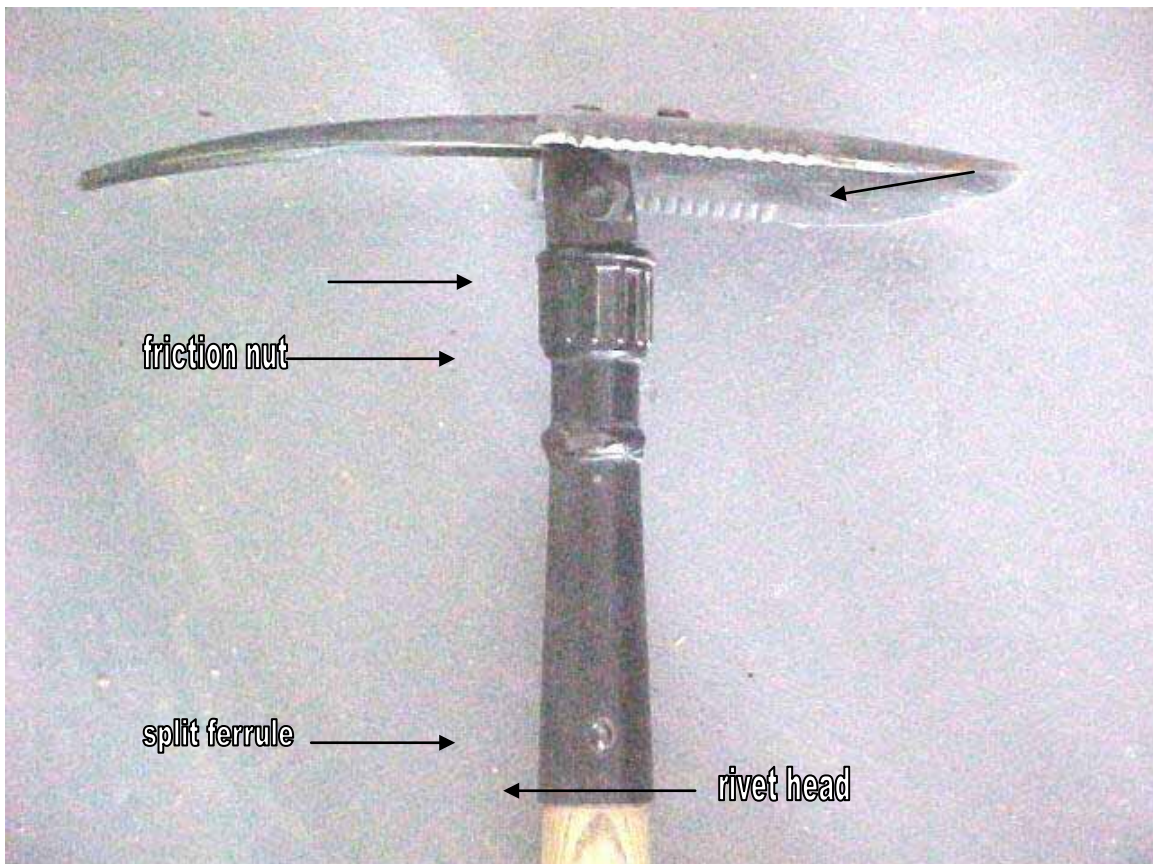

Figure 1- combi tool

Continued –

ITEM: **TOOL**, combination shovel and grub hoe

NFES #001180

**B. Tests**

1. Extend hoe blade and pick at right angles to tool handle.
2. Tighten friction nut (wear gloves). Move blade and pick up and down and further tighten friction nut.
3. Repeat process to ensure that the blade and pick can be maintained tight by the friction nut.
4. If friction nut does not turn freely, flush with water. Blow clean with air gun. (Wear safety glasses). If the nut does not turn freely after flushing, remove the hinge leg bolt and friction nut, and clean the threads inside. Do not use oil on the friction nut threads or hinge bolt, since oil attracts dust and debris.
5. If tool head cannot be tightened, inspect hinge leg surface contact with friction nut. Remove hinge leg bolt; grind hinge legs as needed so they meet flush with friction nut.
6. Replace friction nut if defective.

**C. Refurbishing Procedures**

1. Head.
  - Clean head and friction nut. See B. Tests.
2. Sharpen both blade and pick at 45 degree angle per hand tool. Refer to tool sharpening gauge NFES #000510.
3. Handle.
  - Clean handle.
  - Tighten handle in ferrule by peening rivet head.
  - Scrape and sand handle if chipped, dinged, rough, or has tape or other residues.
4. Handle replacement
  - Grind off end of rivet.
  - Punch it through the handle. Remove the handle from the ferrule.
  - Place the new handle in the ferrule and drill hole through handle.
  - Replace the rivet with a #6 x 1-13/16 inch long rivet. Tap rivet with a hammer to mushroom the rivet head or until the handle is tightened.

Replacement handles are available from GSA (NSN 5120-01-296-3592).

**D. Retesting Criteria--none**

**E. Cleaning Procedures**

See B. Tests.

**F. Repackaging**

Package 10 each in carton NFES #000384, 46" X 11" X 8" (NSN 8115-01-307-2951).

**G. Storage and Shelf Life Checks**

Per local cache requirements to ensure proper serviceability of tools.

ITEM: **TORCH**, drip, 1¼ GL (4.7L) capacity

NFES #000241

**A. Initial Inspection/Disposal Criteria**

1. Visually inspect tank for cracks, splits, and obvious damage that may cause tank to leak. Dispose of.
2. Lock ring will not seal due to thread damage, if so dispose of.
3. Air breather tube is not broken off or missing, if so replace.
4. Visually inspect for correct alignment of; igniter, fuel trap and fuel outlet.
5. Salvage usable component parts.

**B. Tests**

1. Fill drip torch with water inspect for leaks.
2. Place spout and ring on drip torch and remove discharge plug.
3. Turn drip torch with spout down, open vent, water should flow, close vent water should stop.

✓ **CAUTION: Remove any residual fuel before testing and dispose of according to local hazardous materials regulations.**

**C. Refurbishing Procedures**

1. Steam clean or wash with mild degreaser soap, rinse with water, inspect for and remove any scab deposits inside tank.
2. Replace igniter if screen is ruptured, crushed, or tiller is burned out or carbonized. Some carbonization can be cleaned with wire brush.
3. Tighten screw that holds igniter and screen in place.
4. Ensure that the alignment of; igniter, fuel trap and fuel outlet is correct (see figure 3. )
5. Ensure that discharge plug and chain are attached to tank cover assembly.
6. Install discharge plug into the fuel outlet seat.
7. Thoroughly dry all components with clean rag and air hose.
8. There are several different manufacturers of drip torches. Do not mix the components as the drip torch will not function correctly or will leak.
9. Insert spout into tank and tighten lock ring.
10. Replace worn flammable liquid labels if damage

**D. Retesting Criteria--none**

**E. Cleaning Procedures**

See C. Refurbishing Procedures.

**F. Repackaging**

Package 1 each in carton NFES 008189.

**G. Storage and Shelf Life Checks--none**

Continued—

ITEM: **TORCH**, drip, 1¼ GL (4.7L) capacity

NFES #000241

**H. Pictured (figures 1& 2) are two D.O.T approved shipping containers.**

1. Note the UN Markings and Flammable Liquid Label. Drip Torch cans without these Markings and Label may not be used to transport fuel.
2. The Red can is the 'NEW' OSHA approved can for fuel dispensing.

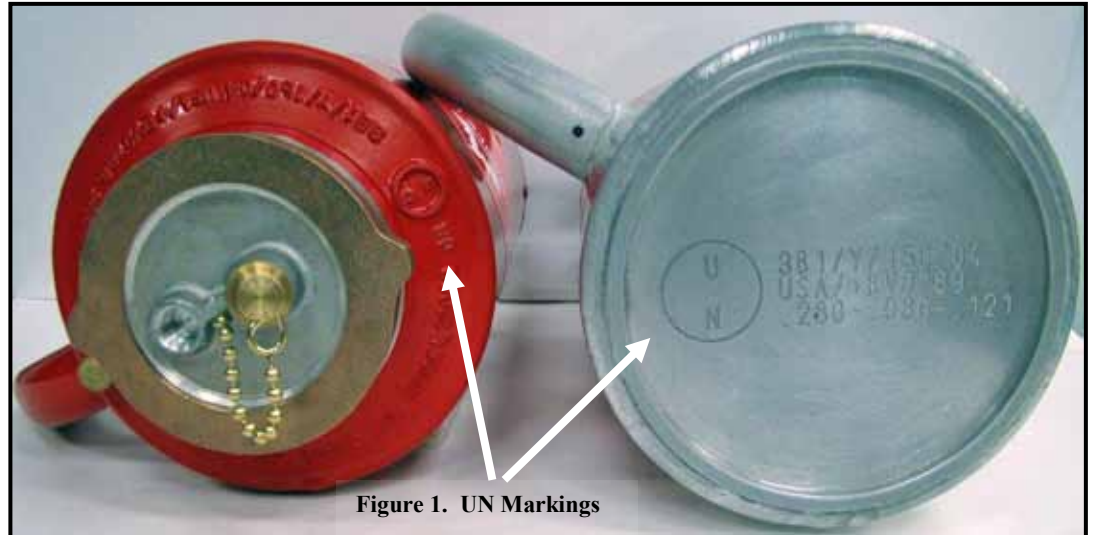

3. Alignment of the igniter, fuel trap and fuel outlet assembly.



IGNITER

FUEL TRAP

FUEL OUTLET

Discharge plug in transport position, fuel outlet is plugged.

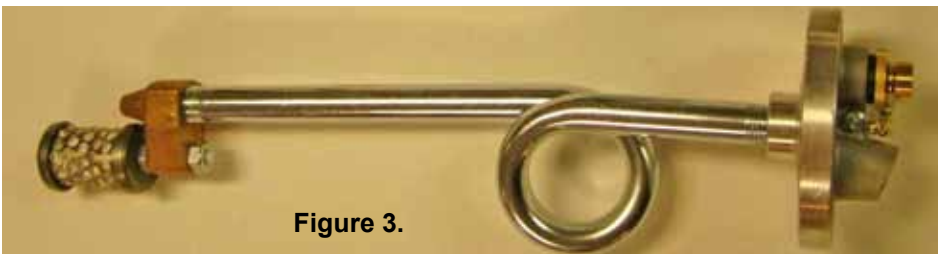

Discharge plug in Parked position, fuel outlet is open

Figure 3.

Continued—

ITEM: TORCH, drip, 1¼ GL (4.7L) capacity

NFES #000241

Figure 4. Exploded parts view.

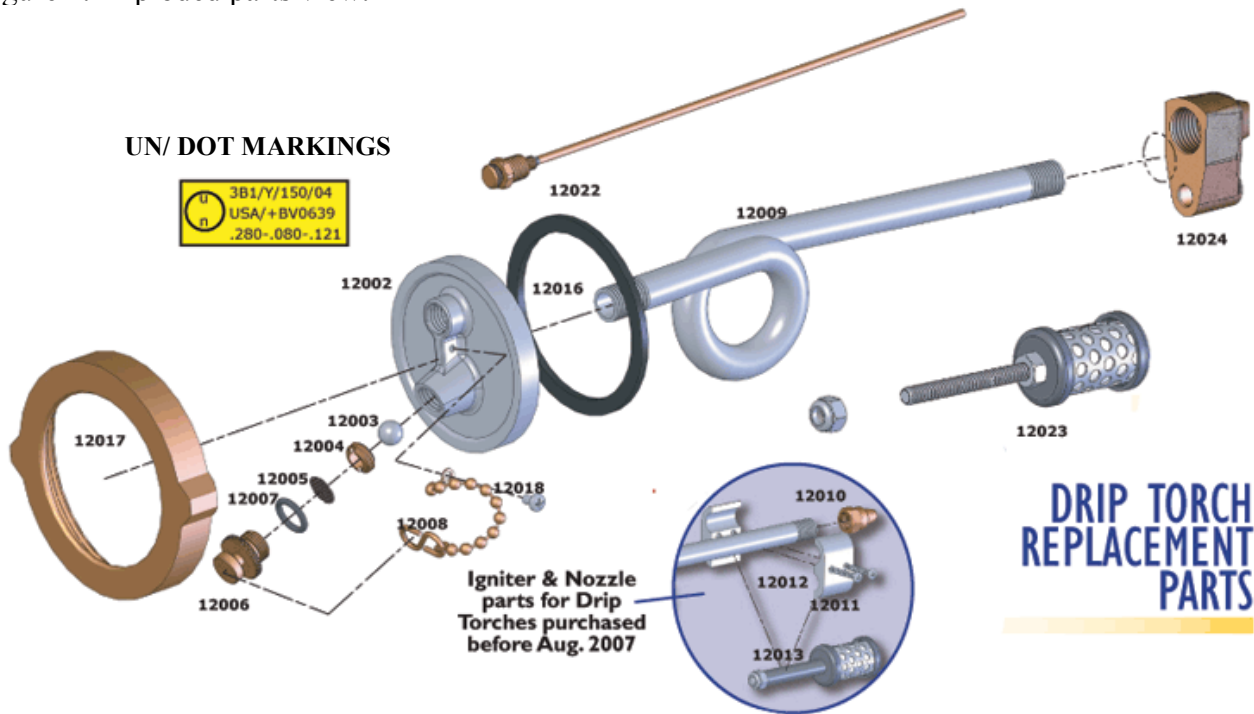

PART	DESCRIPTION
12002	TANK COVER
12003	CHECK VALVE BALL
12004	CHECK VALVE SEAT
12005	OUTLET SCREEN
12006	DISCHARGE SEALING PLUG
12007	DISCHARGE PLUG GASKET
12008	DISCHARGE PLUG CHAIN
12009	SPOUT AND FUEL TRAP
<b>12010</b>	<b>NOZZLE 3/32 BORE</b>
12011	IGNITER CLAMPS (PAIR)
12012	IGNITER CLAMP SCREW
12013	IGNITER
12016	TANK COLLAR GASKET
12017	TANK COVER LOCKRING
12018	CHAIN SCREW
12022	BREATHER TUBE ASSEMBLY
<b>12023</b>	<b>IGNITER</b>
<b>12024</b>	<b>NOZZLE</b>

ITEM: **VALVE**, automatic check and bleeder 1½“NH-F

NFES #000228

**A. Initial Inspection/Disposal Criteria**

1. Visually inspect.
2. Inspect for missing parts (valves, plugs, and gaskets). Replace if missing.
3. Inspect handle. Replace if missing or damaged.
4. Inspect threads. Repair or dispose of.
5. Inspect for fire damage (may cause future failure.) Dispose of.

**B. Tests**

1. Pressure testing.
  - a. Install valve on test pump.
  - b. Fill with water; close handle.
  - c. Attach caps or nozzle for testing.
  - d. Test for leaks at 300 PSI for 3 minutes.
  - e. Inspect for leaks around female coupling.
  - f. Inspect for leaks around male flange.
  - g. Inspect for leaks under top of handle shaft.
  - h. Inspect for leaks on bottom end of handle shaft.
  - i. Inspect for leaks in casing.
2. Repair if valve is found defective.
3. Ensure that the check valve (flapper) is operational.

**C. Refurbishing Procedures**

Replace missing or damaged parts (O-ring, gasket, flapper and handle).

**D. Retesting Criteria**

Retest after repair.

**E. Cleaning Procedures**

1. Wash and clean all items of foreign matter, such as mud, dirt, and grease.
2. Rinse thoroughly.
3. Stand upright to drain and dry.
4. Lubricate female coupling with appropriate dry lubricant such as graphite. Wipe off excess.

**F. Repackaging**

Local cache option.

**G. Storage and Shelf Life Check--none**



## Fire Equipment Storage and Refurbishing Standards

---

ITEM: VALVE, foot, 1½” NH-F w/strainer  
VALVE, foot, 2” NPSH w/strainer

NFES #000212  
NFES #000906

**A. Initial Inspection/Disposal Criteria**

1. Inspect for missing parts (screws, screen, and adaptor when required), replace.
2. Inspect for damaged threads and gaskets, repair or replace.
3. Inspect spring on check valve for smooth operation.

**B. Tests**

Ensure that valve assembly functions.

**C. Refurbishing Procedures**

Repair or replace missing parts.

**D. Retesting Criteria--none**

**E. Cleaning Procedures**

1. All items will be washed and cleaned.
2. Rinse thoroughly.
3. Stand upright to drain and dry.

**F. Repackaging**

Repack 10 per container

**G. Storage and Shelf Life Checks--none**

ITEM: **VALVE**, pressure relief, 1½” NH-F

NFES #000229

**A. Initial Inspection/Disposal Criteria**

1. Visually inspect.
2. Inspect for missing parts.
3. Inspect handle.
4. Inspect threads.

**B. Tests**

1. Pressure testing.
  - a. Install valve on test pump.
  - b. Close handle.
  - c. Attach cap or nozzle for testing.
  - d. Test for leaks at 300 PSI.
  - e. Inspect for leaks around female coupling.
  - f. Inspect for leaks under top of handle shaft.
  - g. Inspect for leaks on bottom end of handle shaft.
  - h. Inspect for leaks in casing.

**C. Refurbishing Procedures**

Replace missing or damaged handle.

**D. Retesting Criteria**

Retest after repair. See B. Tests.

**E. Cleaning Procedures**

1. All items will be washed and cleaned of foreign matter, such as mud, dirt, and grease.
2. Rinse thoroughly.
3. Stand upright to drain and dry.

**F. Repackaging**

Package 10 each in carton (cache option) and label accordingly.

**G. Storage and Shelf Life Checks--none**

## Fire Equipment Storage and Refurbishing Standards

---

ITEM: VALVE, shut off, ball

NFES #001201, #001207, #000738

**A. Initial Inspection/Disposal Criteria**

1. Inspect for obvious damage:
2. Inspect for burrs and thread damage, if so dispose of.
3. Inspect gasket if damaged or missing replace.
4. Collar must turn freely if applicable. (Dispose of or repair)
5. Inspect for fire damage, if so dispose of.

**B. Tests**

1. Gasket:
  - a. Replace if missing.
  - b. Must be in good condition, not cracked or stiff, replace.
  - c. Must be seated properly.
2. Install valve on test pump.
  - a. Close valve and turn on water to valve.
  - b. Open valve to expel air then close valve.
  - c. Turn on pump
  - d. NFES #001201 and NFES #001207 test at 300 PSI for 3 minutes.
  - e. NFES #000738 test at 100 PSI for 3 minutes.
3. Inspect for leaks.
  - a. Around the gasket.
  - b. At the handles.
  - c. If valve leaks, dispose through local procedures.

**C. Refurbishing Procedures**

Replace cracked or missing gasket.

**D. Retesting Criteria--none**

**E. Cleaning Procedures**

1. Wash and clean all items of foreign matter, such as mud, dirt, and grease.
2. Use parts washer, high pressure wash, or clean in a mild detergent with brush or scouring pad as needed.
3. Do not soak for extended periods of time or the detergent will corrode the metal.
4. Rinse thoroughly.
5. Stand upright with barrel in open position to drain water and dry.

**F. Repackaging**

Pack 10 each in carton (local cache option) and label accordingly.

**G. Storage and Shelf Life Checks--none**

**H. Recycle as local cache options are available.**

[National Recycling Coalition - Home](#)

---

## Fire Equipment Storage and Refurbishing Standards

---

ITEM: VALVE, wye, gated

NFES #000259, #000231, #000272

### A. Initial Inspection/Disposal Criteria

Inspect for obvious damage:

1. Handles.
  - a. Bent, if it has a slight bend, replace the handle.
  - b. Broken--replace.
  - c. Missing--replace.
  - d. Too tight--repair or replace.
  - e. Too loose--repair or replace.
  - f. Expansion pins coming out or missing--replace.
  - g. Handles positioned properly--repair.
  - h. Correct handle, left and right--repair.
  - i. Burrs--repair.
2. Male flange, lock-ring, and set-screws--repair or replace.
  - a. Damaged threads--repair or replace.
  - b. Missing—replace.
  - c. Smooth, flat surface on flange--repair or replace.
  - d. Burrs—repair.
  - e. Loose—tighten.
3. Female coupling.
  - a. Coupling spins freely; if not check for wear, replace bearings.
  - b. Gasket is present. Replace if stiff cracked, worn or missing.
  - c. No rough burrs--repair or replace.
4. Casting (body):
  - a. Fire damage—look for further damage, O-rings. Dispose of.
  - b. Corrosion—dispose of.
  - c. Cracks—dispose of.
  - d. Burrs—repair.
5. Plastic sphere  
Inspect sphere while turning handle; if pitted or rough, replace.

### B. Tests

Pressure Testing:

- NFES #000259 & NFES #000231 test at 300 PSI for 3 minutes
  - NFES #000272 test 100 PSI for 3 minutes
1. Install valve on test pump.
  2. Close handles.
  3. Turn on water to valve.
  4. Open handle to expel air.
  5. Turn on pump and check valve for leaks.
    - a. If valve is found to be defective, repair as needed.
    - b. Retest after repair.

### C. Refurbishing Procedures

Replace worn, cracked, or missing O-rings or gasket.

### D. Retesting Criteria

Retest if O-rings or gaskets are replaced according to B. Tests.

## Fire Equipment Storage and Refurbishing Standards

---

Continued--

ITEM: VALVE, wye, gated

NFES #000259, #000231, #000272

**E. Cleaning Procedures**

1. Wash and clean all items of foreign matter, such as mud, dirt, and grease.
2. High pressure wash or clean in a mild detergent with brush or scouring pad as needed. Do not soak for extended periods of time or the detergent will corrode the metal.
3. Rinse thoroughly.
4. Stand upright with handles in half open position to drain water and dry.
5. Lubricate with appropriate type of lubricant.

**F. Repackaging**

NFES #000259 or #000231—package 10 per container.

NFES #000272—100 per container.

**G. Storage and Shelf Life Checks -- none**

**H. Recycle as local cache options are available.**

---

## Fire Equipment Storage and Refurbishing Standards

---

ITEM: **WYE**, plain

NFES #000739, #000839, #000883

**A. Initial Inspection/Disposal Criteria**

1. Inspect for obvious damage, cracks, bad threads, etc. if detected dispose of the wye.
2. Inspect condition of the gaskets for stiffness, damage, or missing, replace.

**B. Tests**

1. Clean threads.
2. Cap male ends.
3. Attach to test pump. Test at 300 PSI. Test NFES# 000739 at 100 PSI.
4. Inspect for leaks.
5. Dispose of if leaking.

**C. Refurbishing Procedures**

Replace gaskets if missing, cracked, or stiff.

**D. Retesting Criteria**

Retest if gasket was replaced.

**E. Cleaning Procedures**

1. Wash to remove all mud, dirt, and grease.
2. High pressure wash or clean in a mild dishwashing detergent with a brush or scouring pad as needed.
3. Do not soak. Detergent may corrode metal.

**F. Repackaging**

Package 10 each NFES #000839 in carton (cache option) and label accordingly.  
Package 10 each NFES #000883 in carton (cache option) and label accordingly  
Package 20 each NFES #000739 in carton (cache option) and label accordingly.

**G. Storage and Shelf Life Checks--none**

**H. Reference**

[Water Handling Equipment Guide, NWCG PMS 447-1](http://www.nwcg.gov/pms/pubs/WHEG03.pdf)  
<http://www.nwcg.gov/pms/pubs/WHEG03.pdf>

**I. Recycle as local cache options are available.**